

GSM with EDGE Guide

Agilent Technologies E4406A VSA Series Transmitter Tester

Options 202, BAH



**Manufacturing Part Number: E4406-90228
Supersedes E4406-90170 and E4406-90174**

Printed in USA

January 2002

© Copyright 1999 - 2002 Agilent Technologies, Inc.

The information contained in this document is subject to change without notice.

Agilent Technologies makes no warranty of any kind with regard to this material, including but not limited to, the implied warranties of merchantability and fitness for a particular purpose. Agilent Technologies shall not be liable for errors contained herein or for incidental or consequential damages in connection with the furnishing, performance, or use of this material.

Contents

1. Understanding GSM and EDGE	
What are GSM and EDGE?	26
What Does the Agilent E4406A VSA Do?	29
EDGE and GSM Measurements	30
Basic Measurements	30
Frequently Used Terms	31
Mobile Stations and Base Transceiver Stations	31
Uplink and Downlink	31
ARFCN	31
Timeslots	31
Other Sources of Measurement Information	32
Instrument Updates at www.agilent.com	32
2. Setting Up the Mode	
Accessing the Mode	34
Making a Measurement	35
Changing the Mode Setup	36
Radio	36
Input	37
Trigger	38
Demod (GSM only)	40
Changing the Frequency Channel	41
Frequency Channel Defaults	43
EDGE and GSM Measurement Key Flow	44
Installing Optional Measurement Personalities	62
Available Measurement Personality Options	62
Loading an Optional Measurement Personality	63
Installing a License Key	64
Viewing a License Key	64
Using the Uninstall Key	65
3. Making Measurements	
GSM and EDGE Measurements	68
Preparing for Measurements	69
Initial Setup	69
Measurement Control	70
Measurement Setup	71
Making the Transmit Power Measurement	74
Purpose	74
Measurement Method	74
Making the Measurement	75
Results	76
Changing the Measurement Setup	77
Troubleshooting Hints	78
Making the GSM Power vs. Time Measurement	79
Purpose	79
Measurement Method	79
Making the Measurement	80

Contents

Results	.82
Changing the Measurement Setup	.85
Changing the View	.86
Changing the Display	.87
Troubleshooting Hints	.87
Making the GMSK Phase and Frequency Error Measurement	.88
Purpose	.88
Measurement Method	.88
Making the Measurement	.89
Results	.89
Changing the Measurement Setup	.92
Changing the View	.93
Changing the Display	.94
Troubleshooting Hints	.94
Making the GMSK Output RF Spectrum Measurement	.95
Purpose	.95
Measurement Method	.95
Making the Measurement	.98
Results	.99
Changing the Measurement Setup	.101
Changing the View	.106
Troubleshooting Hints	.106
Making the GMSK Tx Band Spur Measurement	.107
Purpose	.107
Measurement Method	.107
Making the Measurement	.108
Results	.109
Changing the Measurement Setup	.109
Changing the View	.110
Troubleshooting Hints	.110
Making the EDGE Power vs. Time Measurement	.111
Purpose	.111
Measurement Method	.111
Making the Measurement	.112
Results	.114
Changing the Measurement Setup	.118
Changing the View	.119
Changing the Display	.120
Troubleshooting Hints	.120
Making the EDGE EVM Measurement	.121
Purpose	.121
Measurement Method	.121
Making the Measurement	.122
Results	.122
Changing the Measurement Setup	.123
Changing the View	.123
Changing the Display	.127
Troubleshooting Hints	.129
Making the EDGE Output RF Spectrum Measurement	.130

Contents

Purpose	130
Measurement Method.....	130
Making the Measurement	134
Results	135
Changing the Measurement Setup	136
Changing the View	141
Troubleshooting Hints	141
Making the EDGE Tx Band Spur Measurement	142
Purpose	142
Measurement Method	142
Making the Measurement	143
Results	144
Changing the Measurement Setup	144
Changing the View	145
Troubleshooting Hints	145
Making the Spectrum (Frequency Domain) Measurement	146
Purpose	146
Measurement Method.....	146
Making the Measurement	146
Results	146
Changing the Measurement Setup	147
Changing the View	151
Changing the Display	151
Using the Markers	153
Troubleshooting Hints	154
Making the Waveform (Time Domain) Measurement	155
Purpose	155
Measurement Method.....	155
Making the Measurement	155
Results	156
Changing the Measurement Setup	157
Changing the View	159
Changing the Display	160
Using the Markers	161
Troubleshooting Hints	162
4. Programming Commands	
SCPI Command Subsystems	164
CALCulate Subsystem.....	165
Test Current Results Against all Limits	165
Data Query	165
Calculate/Compress Trace Data Query	166
Calculate Peaks of Trace Data	172
EDGE TX Band Spur Calculate Commands	174
CALCulate:MARKers Subsystem	175
Transmit Band Spurious - Limits	186
CONFigure Subsystem	187
Configure the Selected Measurement	187
Configure Query	187

Contents

DISPlay Subsystem	188
EDGE PVT - Limit Mask On/Off	188
Select Display Format	188
Select Display Format	188
PVT - Limit Mask On/Off	189
Spectrum - Y-Axis Scale/Div	189
Spectrum - Y-Axis Reference Level	190
Turn a Trace Display On/Off	191
Waveform - Y-Axis Scale/Div	194
Waveform - Y-Axis Reference Level	195
FETCh Subsystem	197
Fetch the Current Measurement Results	197
FORMat Subsystem	198
Byte Order	198
Numeric Data format	198
INITiate Subsystem	200
Take New Data Acquisition for Selected Measurement	200
Continuous or Single Measurements	200
Take New Data Acquisitions	201
Restart the Measurement	201
INSTRument Subsystem	203
Catalog Query	203
Select Application by Number	203
Select Application	204
MEASure Group of Commands	206
CONFigure, FETCh, MEASure, READ Interactions	206
EDGE Error Vector Magnitude Measurement	210
EDGE Output RF Spectrum Measurement	213
EDGE Power vs. Time Measurement	216
EDGE Transmit Band Spurs Measure Commands	219
Output RF Spectrum Measurement	220
Phase & Frequency Error Measurement	223
Power vs. Time Measurement	226
Spectrum (Frequency Domain) Measurement	229
Transmit Band Spurs Measurement	231
Transmit Power Measurement	232
Waveform (Time Domain) Measurement	234
READ Subsystem	236
Initiate and Read Measurement Data	236
SENSE Subsystem	237
Channel Commands	237
Signal Corrections Commands	243
EDGE Error Vector Magnitude Measurement	244
EDGE Output RF Spectrum Measurement	248
EDGE Power vs. Time (Burst Power) Measurement	260
EDGE Transmit Band Spurs Measurement	271
Select the Input Signal	273
Output RF Spectrum Measurement	274
Phase & Frequency Error Measurement	287

Contents

RF Power Commands	291
Power vs. Time Measurement	293
Radio Standards Commands	304
Spectrum (Frequency-Domain) Measurement	307
Transmit Band Spurs Measurement	320
Transmit Power Measurement	322
Waveform (Time-Domain) Measurement	326
TRIGger Subsystem	333
Automatic Trigger Control	333
Automatic Trigger Time	333
External Trigger Delay	334
External Trigger Level	334
External Trigger Slope	334
Frame Trigger Adjust	335
Frame Trigger Period	335
Frame Trigger Sync Source	336
Frame Trigger Synchronization Offset	336
Trigger Holdoff	337
Video (IF) Trigger Delay	337
Video (IF) Trigger Level	337
Video (IF) Trigger Slope	339
RF Burst Trigger Delay	339
RF Burst Trigger Level	339
RF Burst Trigger Slope	340

:CALCulate:<measurement>:MARKer:AOFF	177
:CALCulate:<measurement>:MARKer[1] 2 3 4:FUNctIon:RESult?	178
:CALCulate:<measurement>:MARKer[1] 2 3 4:MAXimum	178
:CALCulate:<measurement>:MARKer[1] 2 3 4:MINimum	178
:CALCulate:<measurement>:MARKer[1] 2 3 4:MODE POSition DELTA	177
:CALCulate:<measurement>:MARKer[1] 2 3 4:MODE POSition DELTA	179
:CALCulate:<measurement>:MARKer[1] 2 3 4:MODE POSition DELTA RMSDegree RMSRadian RFM RMSJitter OFF	179
:CALCulate:<measurement>:MARKer[1] 2 3 4:MODE?	177
:CALCulate:<measurement>:MARKer[1] 2 3 4:MODE?	179
:CALCulate:<measurement>:MARKer[1] 2 3 4:TRACe <trace_name>	180
:CALCulate:<measurement>:MARKer[1] 2 3 4:TRACe?	180
:CALCulate:<measurement>:MARKer[1] 2 3 4:X <param>	184
:CALCulate:<measurement>:MARKer[1] 2 3 4:X:POSition <integer>	184
:CALCulate:<measurement>:MARKer[1] 2 3 4:X:POSition?	184
:CALCulate:<measurement>:MARKer[1] 2 3 4:X?	184
:CALCulate:<measurement>:MARKer[1] 2 3 4:Y?	185
:CALCulate:<measurement>:MARKer[1] 2 3 4:[STATe] OFF ON 0 1	179
:CALCulate:<measurement>:MARKer[1] 2 3 4:[STATe]?	179
:CALCulate:CLIMits:FAIL?	165
:CALCulate:DATA<n>:COMPRESS? BLOCk CFIT MAXimum MEAN MINimum RMS SAMPlE SDEViation[,<soffset>[, <length>[,<roffset>[,<rlimit>]]]]	166
:CALCulate:DATA<n>:PEAKs? <threshold>,<excursion>[,AMPLitude FREQuency TIME]	172
:CALCulate:DATA[n]?	165
:CALCulate:ETSPur:LIMit:TEST ABSolute RELative	174
:CALCulate:ETSPur:LIMit:TEST?	174
:CALCulate:ETSPur:LIMit[:UPPer][:DATA] <power>	174
:CALCulate:ETSPur:LIMit[:UPPer][:DATA]?	174
:CALCulate:TSPur:LIMit:TEST ABSolute RELative	186
:CALCulate:TSPur:LIMit:TEST?	186
:CALCulate:TSPur:LIMit[:UPPer][:DATA] <power>	186
:CALCulate:TSPur:LIMit[:UPPer][:DATA]?	186
:CONFigure:<measurement>	187

:CONFigure:EEVM	.210
:CONFigure:EORFspectr	.213
:CONFigure:EPVTime	.216
:CONFigure:ETSPur	.219
:CONFigure:ORFSpectrum	.220
:CONFigure:PFERror	.223
:CONFigure:PVTime	.226
:CONFigure:SPECTrum	.229
:CONFigure:TSPur	.231
:CONFigure:TXPower	.232
:CONFigure:WAVEform	.234
:CONFigure?.	.187
:DISPlay:EPVTime:LIMit:MASK OFF ON 0 1.	.188
:DISPlay:EPVTime:LIMit:MASK?	.188
:DISPlay:FORMat:TILE	.188
:DISPlay:FORMat:ZOOM	.188
:DISPlay:PVTime:LIMit:MASK OFF ON 0 1	.189
:DISPlay:PVTime:LIMit:MASK?.	.189
:DISPlay:SPECTrum[n]:WINDow[m]:TRACe:Y[:SCALe]:PDIVision <power>.	.189
:DISPlay:SPECTrum[n]:WINDow[m]:TRACe:Y[:SCALe]:PDIVision?.	.189
:DISPlay:SPECTrum[n]:WINDow[m]:TRACe:Y[:SCALe]:RLEVel <power>	.190
:DISPlay:SPECTrum[n]:WINDow[m]:TRACe:Y[:SCALe]:RLEVel?.	.190
:DISPlay:TRACe[n][:STATe] OFF ON 0 1.	.191
:DISPlay:TRACe[n][:STATe]?	.191
:DISPlay:WAVEform[n]:WINDow[m]:TRACe:Y[:SCALe]:PDIVision <power>	.194
:DISPlay:WAVEform[n]:WINDow[m]:TRACe:Y[:SCALe]:PDIVision?	.195
:DISPlay:WAVEform[n]:WINDow[m]:TRACe:Y[:SCALe]:RLEVel <power>	.195
:DISPlay:WAVEform[n]:WINDow[m]:TRACe:Y[:SCALe]:RLEVel?	.195
:FETCh:<measurement>[n]?	.197
:FETCh:EEVM[n]?	.210
:FETCh:EORFspectr[n]?	.213
:FETCh:EPVTime[n]?	.216
:FETCh:ETSPur[n]?	.219
:FETCh:ORFSpectrum[n]?	.220

:FETCh:PFERror[n]?	223
:FETCh:PVTime[n]?	226
:FETCh:SPECTrum[n]?	229
:FETCh:TSPur[n]?	231
:FETCh:TXPower[n]?	232
:FETCh:WAVEform[n]?	234
:FORMat:BORDER NORMal SWAPped	198
:FORMat:BORDER?	198
:FORMat[:DATA] ASCii REAL,32 REAL,64.	198
:FORMat[:DATA]?	198
:INITiate:<measurement_name>	200
:INITiate:CONTInuous OFF ON 0 1	200
:INITiate:CONTInuous?	200
:INITiate:EEVM	210
:INITiate:EORFspectr	213
:INITiate:EPVTime.	216
:INITiate:ETSPur	219
:INITiate:ORFSpectrum.	220
:INITiate:PFERror	223
:INITiate:PVTime	226
:INITiate:REStart	201
:INITiate:SPECTrum.	229
:INITiate:TSPur	231
:INITiate:TXPower	232
:INITiate:WAVEform	234
:INITiate[:IMMediate]	201
:INSTrument:CATalog[:FULL]?	203
:INSTrument:NSElect <integer>	203
:INSTrument:NSElect?	203
:INSTrument[:SElect] BASIC SERICE CDA CDMA2K GSM EDGEGSM IDEN NADC PDC WCDMA CDMA1XEV	204
:INSTrument[:SElect]?	204
:MEASure:EEVM[n]?	210
:MEASure:EORFspectr[n]?	213

:MEASure:EPVTime[n]?	.216
:MEASure:ETSPur[n]?	.219
:MEASure:ORFSpectrum[n]?	.220
:MEASure:PFERror[n]?	.223
:MEASure:PVTime[n]?	.226
:MEASure:SPECtrum[n]?	.229
:MEASure:TSPur[n]?	.231
:MEASure:TXPower[n]?	.232
:MEASure:WAVEform[n]?	.234
:READ:<measurement>[n]?	.236
:READ:EEVM[n]?	.210
:READ:EORFspectr[n]?	.213
:READ:EPVTime[n]?	.216
:READ:ETSPur[n]?	.219
:READ:ORFSpectrum[n]?	.220
:READ:PFERror[n]?	.223
:READ:PVTime[n]?	.226
:READ:SPECtrum[n]?	.229
:READ:TSPur[n]?	.231
:READ:TXPower[n]?	.232
:READ:WAVEform[n]?	.234
:SENSe]:EPVTime:PCLevel?	.268
:TRIGger[:SEQuence]:AUTO:STATe OFF ON 0 1	.333
:TRIGger[:SEQuence]:AUTO:STATe?	.333
:TRIGger[:SEQuence]:AUTO[:TIME] <time>.	.333
:TRIGger[:SEQuence]:AUTO[:TIME]?	.333
:TRIGger[:SEQuence]:EXTernal[1] 2:DELay <time>.	.334
:TRIGger[:SEQuence]:EXTernal[1] 2:DELay?	.334
:TRIGger[:SEQuence]:EXTernal[1] 2:LEVel <voltage>	.334
:TRIGger[:SEQuence]:EXTernal[1] 2:LEVel?	.334
:TRIGger[:SEQuence]:EXTernal[1] 2:SLOPe NEGative POSitive	.334
:TRIGger[:SEQuence]:EXTernal[1] 2:SLOPe?	.335
:TRIGger[:SEQuence]:FRAMe:ADJust <time>	.335
:TRIGger[:SEQuence]:FRAMe:PERiod <time>	.335

:TRIGger[:SEQuence]:FRAMe:PERiod?	335
:TRIGger[:SEQuence]:FRAMe:SYNC EXTFRont EXTRear OFF.	336
:TRIGger[:SEQuence]:FRAMe:SYNC:OFFSet <time>	336
:TRIGger[:SEQuence]:FRAMe:SYNC:OFFSet?	336
:TRIGger[:SEQuence]:FRAMe:SYNC?	336
:TRIGger[:SEQuence]:HOLDoff <time>	337
:TRIGger[:SEQuence]:HOLDoff?	337
:TRIGger[:SEQuence]:IF:DELay <time>	337
:TRIGger[:SEQuence]:IF:DELay?	337
:TRIGger[:SEQuence]:IF:LEVel <ampl>	337
:TRIGger[:SEQuence]:IF:LEVel?	337
:TRIGger[:SEQuence]:IF:SLOPe NEGative POSitive	339
:TRIGger[:SEQuence]:IF:SLOPe?	339
:TRIGger[:SEQuence]:RFBurst:DELay <time>	339
:TRIGger[:SEQuence]:RFBurst:DELay?	339
:TRIGger[:SEQuence]:RFBurst:LEVel <rel_power>	339
:TRIGger[:SEQuence]:RFBurst:LEVel?	339
:TRIGger[:SEQuence]:RFBurst:SLOPe NEGative POSitive	340
:TRIGger[:SEQuence]:RFBurst:SLOPe?	340
[:SENSe]:CHANnel:ARFCn RFCHannel <integer>	237
[:SENSe]:CHANnel:ARFCn RFCHannel:BOTTom	237
[:SENSe]:CHANnel:ARFCn RFCHannel:MIDDLE	238
[:SENSe]:CHANnel:ARFCn RFCHannel:TOP	239
[:SENSe]:CHANnel:ARFCn RFCHannel?	237
[:SENSe]:CHANnel:BURSt NORMal SYNC ACCess	239
[:SENSe]:CHANnel:BURSt?	239
[:SENSe]:CHANnel:SLOT <integer>	240
[:SENSe]:CHANnel:SLOT:AUTO OFF ON 0 1	240
[:SENSe]:CHANnel:SLOT:AUTO?	240
[:SENSe]:CHANnel:SLOT?	240
[:SENSe]:CHANnel:TSCode <integer>	242
[:SENSe]:CHANnel:TSCode:AUTO OFF ON 0 1	242
[:SENSe]:CHANnel:TSCode:AUTO?	242
[:SENSe]:CHANnel:TSCode?	242

[:SENSe]:CORRection:BTS[:RF]:LOSS <rel_power>243
[:SENSe]:CORRection:BTS[:RF]:LOSS?243
[:SENSe]:CORRection:MS[:RF]:LOSS <rel_power>243
[:SENSe]:CORRection:MS[:RF]:LOSS?243
[:SENSe]:EEVM:AVERAge:COUNt <integer>244
[:SENSe]:EEVM:AVERAge:COUNt?244
[:SENSe]:EEVM:AVERAge:TCONtrol EXPOntial REPeat244
[:SENSe]:EEVM:AVERAge:TCONtrol?244
[:SENSe]:EEVM:AVERAge[:STATe] OFF ON 0 1244
[:SENSe]:EEVM:AVERAge[:STATe]?244
[:SENSe]:EEVM:BSYNc:SOURce RFBurst TSEQuence NONE245
[:SENSe]:EEVM:BSYNc:SOURce?245
[:SENSe]:EEVM:DRooP OFF ON 0 1245
[:SENSe]:EEVM:DRooP?245
[:SENSe]:EEVM:ELIMit OFF ON 0 1246
[:SENSe]:EEVM:ELIMit?246
[:SENSe]:EEVM:SDOTs OFF ON 0 1246
[:SENSe]:EEVM:SDOTs?246
[:SENSe]:EEVM:TRACe:SDOTs <integer>246
[:SENSe]:EEVM:TRACe:SDOTs?246
[:SENSe]:EEVM:TRIGger:SOURce EXTernal[1] EXTernal2 FRAME IF IMMEDIATE RFBurst247
[:SENSe]:EEVM:TRIGger:SOURce?247
[:SENSe]:EORFspectr:AVERAge:COUNt <integer>248
[:SENSe]:EORFspectr:AVERAge:COUNt?248
[:SENSe]:EORFspectr:AVERAge:FAST[:STATe] OFF ON 0 1248
[:SENSe]:EORFspectr:AVERAge:FAST[:STATe]?248
[:SENSe]:EORFspectr:AVERAge:MODulation:TYPE LOG RMS249
[:SENSe]:EORFspectr:AVERAge:MODulation:TYPE?249
[:SENSe]:EORFspectr:AVERAge[:STATe] OFF ON 0 1249
[:SENSe]:EORFspectr:AVERAge[:STATe]?249
[:SENSe]:EORFspectr:BANDwidth BWIDth[:RESolution] :MODulation:CARRier <freq>249
[:SENSe]:EORFspectr:BANDwidth BWIDth[:RESolution] :MODulation:CARRier?249

[:SENSe]:EORFspectr:BANDwidth BWIDth[:RESolution] :MODulation:OFFSet:CLOSe <freq>	250
[:SENSe]:EORFspectr:BANDwidth BWIDth[:RESolution] :MODulation:OFFSet:CLOSe?	250
[:SENSe]:EORFspectr:BANDwidth BWIDth[:RESolution] :MODulation:OFFSet:FAR <freq>	250
[:SENSe]:EORFspectr:BANDwidth BWIDth[:RESolution] :MODulation:OFFSet:FAR?	250
[:SENSe]:EORFspectr:BANDwidth BWIDth[:RESolution] :SWITching:CARRier <freq>	251
[:SENSe]:EORFspectr:BANDwidth BWIDth[:RESolution] :SWITching:CARRier?	251
[:SENSe]:EORFspectr:BANDwidth BWIDth[:RESolution] :SWITching:OFFSet:CLOSe <freq>	251
[:SENSe]:EORFspectr:BANDwidth BWIDth[:RESolution] :SWITching:OFFSet:CLOSe?	251
[:SENSe]:EORFspectr:BANDwidth BWIDth[:RESolution] :SWITching:OFFSet:FAR <freq>	251
[:SENSe]:EORFspectr:BANDwidth BWIDth[:RESolution] :SWITching:OFFSet:FAR?	252
[:SENSe]:EORFspectr:BFRequency <freq>	252
[:SENSe]:EORFspectr:BFRequency?	252
[:SENSe]:EORFspectr:LIST:MODulation:BANDwidth BWIDth <res bw>{,<res bw>}	252
[:SENSe]:EORFspectr:LIST:MODulation:BANDwidth BWIDth?	252
[:SENSe]:EORFspectr:LIST:MODulation:LOFFset <level>{,<level>}	253
[:SENSe]:EORFspectr:LIST:MODulation:LOFFset?	254
[:SENSe]:EORFspectr:LIST:MODulation[:FREQuency] <offset freq>{,<offset freq>}	253
[:SENSe]:EORFspectr:LIST:MODulation[:FREQuency]?	253
[:SENSe]:EORFspectr:LIST:SElect CUSTom SHORt STANdard	254
[:SENSe]:EORFspectr:LIST:SElect?	254
[:SENSe]:EORFspectr:LIST:SWITching:BANDwidth BWIDth <res bw>{,<res bw>}	255
[:SENSe]:EORFspectr:LIST:SWITching:BANDwidth BWIDth?	255
[:SENSe]:EORFspectr:LIST:SWITching:LOFFset <level>{,<level>}	256
[:SENSe]:EORFspectr:LIST:SWITching:LOFFset?	256
[:SENSe]:EORFspectr:LIST:SWITching[:FREQuency] <offset freq>{,<offset freq>}	256

[[:SENSE]:EORFspectr:LIST:SWITching[:FREQuency]]?	256
[[:SENSE]:EORFspectr:MEASure MULTIPLE SINGLE]	257
[[:SENSE]:EORFspectr:MEASure?]	257
[[:SENSE]:EORFspectr:OFRequency <freq>]	257
[[:SENSE]:EORFspectr:OFRequency?]	257
[[:SENSE]:EORFspectr:TRIGger:SOURce EXTernal[1] EXTernal2 FRAMe IMMEDIATE RFBurst]	258
[[:SENSE]:EORFspectr:TRIGger:SOURce?]	258
[[:SENSE]:EORFspectr:TYPE MODulation MSWitching SWITching FFModulation]	258
[[:SENSE]:EORFspectr:TYPE:MODulation[:METHod] DIScrete SWEep]	259
[[:SENSE]:EORFspectr:TYPE:MODulation[:METHod]?]	259
[[:SENSE]:EORFspectr:TYPE?]	258
[[:SENSE]:EPVTime:AVERAge:COUNt <integer>]	260
[[:SENSE]:EPVTime:AVERAge:COUNt?]	260
[[:SENSE]:EPVTime:AVERAge:TCONtrol EXPonential REPEAT]	260
[[:SENSE]:EPVTime:AVERAge:TCONtrol?]	260
[[:SENSE]:EPVTime:AVERAge:TYPE LOG MAXimum MINimum MXMinimum RMS]	261
[[:SENSE]:EPVTime:AVERAge:TYPE?]	261
[[:SENSE]:EPVTime:AVERAge[:STATe] OFF ON 0 1]	260
[[:SENSE]:EPVTime:AVERAge[:STATe]?]	260
[[:SENSE]:EPVTime:BANDwidth BWIDth[:RESolution] <freq>]	261
[[:SENSE]:EPVTime:BANDwidth BWIDth[:RESolution]:TYPE FLATtop GAUSSian]	262
[[:SENSE]:EPVTime:BANDwidth BWIDth[:RESolution]:TYPE?]	262
[[:SENSE]:EPVTime:BANDwidth BWIDth[:RESolution]?]	261
[[:SENSE]:EPVTime:BSYNc:SOURce RFBurst TSEQUence]	262
[[:SENSE]:EPVTime:BSYNc:SOURce?]	262
[[:SENSE]:EPVTime:LIMit:MASK OFF ON 0 1]	262
[[:SENSE]:EPVTime:LIMit:MASK?]	262
[[:SENSE]:EPVTime:MASK:LIST:LOWer:ABSolute <power>{,<power>}]	263
[[:SENSE]:EPVTime:MASK:LIST:LOWer:ABSolute?]	263
[[:SENSE]:EPVTime:MASK:LIST:LOWer:POINts?]	263
[[:SENSE]:EPVTime:MASK:LIST:LOWer:RELative <rel_power>{,<rel_power>}]	264
[[:SENSE]:EPVTime:MASK:LIST:LOWer:RELative?]	264
[[:SENSE]:EPVTime:MASK:LIST:LOWer:TIME <seconds>{,<seconds>}]	264

[:SENSe]:EPVTime:MASK:LIST:LOWer:TIME?	264
[:SENSe]:EPVTime:MASK:LIST:UPPer:ABSolute <power>{,<power>}	265
[:SENSe]:EPVTime:MASK:LIST:UPPer:ABSolute?	265
[:SENSe]:EPVTime:MASK:LIST:UPPer:POINts?	266
[:SENSe]:EPVTime:MASK:LIST:UPPer:RELative <rel_power>{,<rel_power>}	266
[:SENSe]:EPVTime:MASK:LIST:UPPer:RELative?	266
[:SENSe]:EPVTime:MASK:LIST:UPPer:TIME <seconds>{,<seconds>}	267
[:SENSe]:EPVTime:MASK:LIST:UPPer:TIME?	267
[:SENSe]:EPVTime:MASK:SElect STANdard CUSTom	265
[:SENSe]:EPVTime:MASK:SElect?	265
[:SENSe]:EPVTime:PCLevel <integer>	268
[:SENSe]:EPVTime:SWEep:TIME <integer>	269
[:SENSe]:EPVTime:SWEep:TIME?	269
[:SENSe]:EPVTime:TRIGger:SOURce EXTernal[1] EXTernal2 FRAMe IF IMMEDIATE RFBurst	269
[:SENSe]:EPVTime:TRIGger:SOURce?	269
[:SENSe]:ETSPur:AVERage:COUNT <integer>	271
[:SENSe]:ETSPur:AVERage:COUNT?	271
[:SENSe]:ETSPur:AVERage:TCONtrol EXPonential REPEAT	271
[:SENSe]:ETSPur:AVERage:TCONtrol?	271
[:SENSe]:ETSPur:AVERage:TYPE LOG MAXimum RMS	272
[:SENSe]:ETSPur:AVERage:TYPE?	272
[:SENSe]:ETSPur:AVERage[::STATe] OFF ON 0 1	271
[:SENSe]:ETSPur:AVERage[::STATe]?	271
[:SENSe]:ETSPur:TYPE EXAMine FULL	272
[:SENSe]:ETSPur:TYPE?	272
[:SENSe]:FEED RF AREFERENCE IFAlign	273
[:SENSe]:FEED?	273
[:SENSe]:ORFSpectrum:AVERage:COUNT <integer>	274
[:SENSe]:ORFSpectrum:AVERage:COUNT?	274
[:SENSe]:ORFSpectrum:AVERage:FAST[::STATe] OFF ON 0 1	274
[:SENSe]:ORFSpectrum:AVERage:FAST[::STATe]?	274
[:SENSe]:ORFSpectrum:AVERage:MODulation:TYPE LOG RMS	275
[:SENSe]:ORFSpectrum:AVERage:MODulation:TYPE?	275

[:SENSe]:ORFSpectrum:AVERAge:SWITChing:TYPE?275
[:SENSe]:ORFSpectrum:AVERAge[:STATe] OFF ON 0 1275
[:SENSe]:ORFSpectrum:AVERAge[:STATe]?275
[:SENSe]:ORFSpectrum:BANDwidth BWIDth[:RESolution] :MODulation:CARRier <freq>276
[:SENSe]:ORFSpectrum:BANDwidth BWIDth[:RESolution] :MODulation:CARRier?276
[:SENSe]:ORFSpectrum:BANDwidth BWIDth[:RESolution] :MODulation:OFFSet:CLOSe <freq>276
[:SENSe]:ORFSpectrum:BANDwidth BWIDth[:RESolution] :MODulation:OFFSet:CLOSe?276
[:SENSe]:ORFSpectrum:BANDwidth BWIDth[:RESolution] :MODulation:OFFSet:FAR <freq>276
[:SENSe]:ORFSpectrum:BANDwidth BWIDth[:RESolution] :MODulation:OFFSet:FAR?277
[:SENSe]:ORFSpectrum:BANDwidth BWIDth[:RESolution] :SWITChing:CARRier <freq>277
[:SENSe]:ORFSpectrum:BANDwidth BWIDth[:RESolution] :SWITChing:CARRier?277
[:SENSe]:ORFSpectrum:BANDwidth BWIDth[:RESolution] :SWITChing:OFFSet:CLOSe <freq>277
[:SENSe]:ORFSpectrum:BANDwidth BWIDth[:RESolution] :SWITChing:OFFSet:CLOSe?277
[:SENSe]:ORFSpectrum:BANDwidth BWIDth[:RESolution] :SWITChing:OFFSet:FAR <freq>279
[:SENSe]:ORFSpectrum:BANDwidth BWIDth[:RESolution] :SWITChing:OFFSet:FAR?279
[:SENSe]:ORFSpectrum:BFRequency <freq>279
[:SENSe]:ORFSpectrum:BFRequency?279
[:SENSe]:ORFSpectrum:LIST:MODulation:BANDwidth BWIDth <res bw>{,<res bw>}.279
[:SENSe]:ORFSpectrum:LIST:MODulation:BANDwidth BWIDth?280
[:SENSe]:ORFSpectrum:LIST:MODulation:LOFFset <level>{,<level>}.280
[:SENSe]:ORFSpectrum:LIST:MODulation:LOFFset?281
[:SENSe]:ORFSpectrum:LIST:MODulation[:FREQuency] <offset freq>{,<offset freq>}.280
[:SENSe]:ORFSpectrum:LIST:MODulation[:FREQuency]?280
[:SENSe]:ORFSpectrum:LIST:SElect?281
[:SENSe]:ORFSpectrum:LIST:SWITChing:BANDwidth BWIDth <res_bw>{,<res_bw>}282

[:SENSe]:ORFSpectrum:LIST:SWITching:BWIDth?	282
[:SENSe]:ORFSpectrum:LIST:SWITching:LOFFset <level>{,<level>}	283
[:SENSe]:ORFSpectrum:LIST:SWITching:LOFFset?	283
[:SENSe]:ORFSpectrum:LIST:SWITching:FREQuency <offset_freq>{,<offset_freq>}	283
[:SENSe]:ORFSpectrum:LIST:SWITching:FREQuency?	283
[:SENSe]:ORFSpectrum:MEASure MULTiple SINGLE	284
[:SENSe]:ORFSpectrum:MEASure?	284
[:SENSe]:ORFSpectrum:OFRequency <freq>	284
[:SENSe]:ORFSpectrum:OFRequency?	284
[:SENSe]:ORFSpectrum:TRIGger:SOURce EXTernal[1] EXTernal2 FRAME IMMEDIATE RFBurst	285
[:SENSe]:ORFSpectrum:TRIGger:SOURce?	285
[:SENSe]:ORFSpectrum:TYPE MODulation MSWitching SWITching FFModulation	285
[:SENSe]:ORFSpectrum:TYPE:MODulation[:METHod] DISCrete SWEep	286
[:SENSe]:ORFSpectrum:TYPE:MODulation[:METHod]?	286
[:SENSe]:ORFSpectrum:TYPE?	285
[:SENSe]:PFERror:AVERAge:COUNT <integer>	287
[:SENSe]:PFERror:AVERAge:COUNT?	287
[:SENSe]:PFERror:AVERAge:TCONtrol EXPonential REPeat	287
[:SENSe]:PFERror:AVERAge:TCONtrol?	287
[:SENSe]:PFERror:AVERAge:TYPE MEAN MAXimum	288
[:SENSe]:PFERror:AVERAge:TYPE?	288
[:SENSe]:PFERror:AVERAge[:STATe] OFF ON 0 1	287
[:SENSe]:PFERror:AVERAge[:STATe]?	287
[:SENSe]:PFERror:BSYNc:SOURce EXTernal[1] EXTernal2 NONE RFBurst TSEQUence	288
[:SENSe]:PFERror:BSYNc:SOURce?	288
[:SENSe]:PFERror:TRIGger:SOURce EXTernal[1] EXTernal2 FRAME IF IMMEDIATE RFBurst	290
[:SENSe]:PFERror:TRIGger:SOURce?	290
[:SENSe]:POWER[:RF]:ATTenuation <rel_power>	291
[:SENSe]:POWER[:RF]:ATTenuation?	291
[:SENSe]:POWER[:RF]:RANGe:AUTO OFF ON 0 1	291
[:SENSe]:POWER[:RF]:RANGe:AUTO?	291
[:SENSe]:POWER[:RF]:RANGe[:UPPer] <power>	291

[[:SENSE]:POWER[:RF]:RANGE[:UPPER]?	291
[[:SENSE]:PVTime:AVERAge:COUNT <integer>.....	293
[[:SENSE]:PVTime:AVERAge:COUNT?.....	293
[[:SENSE]:PVTime:AVERAge:TCONtrol EXPONential REPeat	293
[[:SENSE]:PVTime:AVERAge:TCONtrol?.....	293
[[:SENSE]:PVTime:AVERAge:TYPE LOG MAXimum MINimum MXMinimum RMS	294
[[:SENSE]:PVTime:AVERAge:TYPE?	294
[[:SENSE]:PVTime:AVERAge[:STATe] OFF ON 0 1.....	293
[[:SENSE]:PVTime:AVERAge[:STATe]?	293
[[:SENSE]:PVTime:BANDwidth BWIDth[:RESolution] <freq>.....	294
[[:SENSE]:PVTime:BANDwidth BWIDth[:RESolution]:TYPE FLATtop GAUSSian	295
[[:SENSE]:PVTime:BANDwidth BWIDth[:RESolution]:TYPE?	295
[[:SENSE]:PVTime:BANDwidth BWIDth[:RESolution]?.....	294
[[:SENSE]:PVTime:BSYNc:SOURce RFBurst TSEQUence	295
[[:SENSE]:PVTime:BSYNc:SOURce?	295
[[:SENSE]:PVTime:LIMit:MASK OFF ON 0 1.....	295
[[:SENSE]:PVTime:LIMit:MASK?	295
[[:SENSE]:PVTime:MASK:LIST:LOWer:ABSolute <power>{,<power>}	296
[[:SENSE]:PVTime:MASK:LIST:LOWer:ABSolute?	296
[[:SENSE]:PVTime:MASK:LIST:LOWer:POINts?.....	296
[[:SENSE]:PVTime:MASK:LIST:LOWer:RELative <rel_power>{,<rel_power>}.....	297
[[:SENSE]:PVTime:MASK:LIST:LOWer:RELative?	297
[[:SENSE]:PVTime:MASK:LIST:LOWer:TIME <seconds>{,<seconds>}.....	297
[[:SENSE]:PVTime:MASK:LIST:LOWer:TIME?	297
[[:SENSE]:PVTime:MASK:LIST:UPPer:ABSolute <power>{,<power>}.....	298
[[:SENSE]:PVTime:MASK:LIST:UPPer:ABSolute?.....	298
[[:SENSE]:PVTime:MASK:LIST:UPPer:POINts?	299
[[:SENSE]:PVTime:MASK:LIST:UPPer:RELative <rel_power>{,<rel_power>}.....	299
[[:SENSE]:PVTime:MASK:LIST:UPPer:RELative?.....	299
[[:SENSE]:PVTime:MASK:LIST:UPPer:TIME <seconds>{,<seconds>}	299
[[:SENSE]:PVTime:MASK:LIST:UPPer:TIME?.....	299
[[:SENSE]:PVTime:MASK:SELect STANdard CUSTom	301
[[:SENSE]:PVTime:MASK:SELect?	301

[:SENSe]:PVTime:PCLevel <integer>	302
[:SENSe]:PVTime:PCLevel?	302
[:SENSe]:PVTime:SWEEP:TIME <integer>	302
[:SENSe]:PVTime:SWEEP:TIME?	302
[:SENSe]:PVTime:TRIGGER:SOURCE External[1] External2 FRAME IF IMMEDIATE RFBURST	302
[:SENSe]:PVTime:TRIGGER:SOURCE?	302
[:SENSe]:RADio:CARRIER:HOP OFF ON 0 1	304
[:SENSe]:RADio:CARRIER:HOP?	304
[:SENSe]:RADio:CARRIER[:TYPE] BURST CONTINUOUS	304
[:SENSe]:RADio:CARRIER[:TYPE]?	304
[:SENSe]:RADio:DEVICE BTS MS	304
[:SENSe]:RADio:DEVICE:BASE[:TYPE] NORMAL MICRO PICO	305
[:SENSe]:RADio:DEVICE:BASE[:TYPE]?	305
[:SENSe]:RADio:DEVICE?	304
[:SENSe]:RADio:STANDARD:BAND PGSM900 EGSM900 RGSM900 DCS1800 PCS1900 GSM450 GSM480 GSM850	305
[:SENSe]:RADio:STANDARD:BAND?	305
[:SENSe]:SPECTrum:ACQUISITION:PACKING AUTO LONG MEDIUM SHORT	307
[:SENSe]:SPECTrum:ACQUISITION:PACKING?	307
[:SENSe]:SPECTrum:ADC:DITHER[:STATE] AUTO ON OFF 2 1 0	307
[:SENSe]:SPECTrum:ADC:DITHER[:STATE]?	307
[:SENSe]:SPECTrum:ADC:RANGE AUTO APEAK APLock NONE P0 P6 P12 P18	307
[:SENSe]:SPECTrum:ADC:RANGE?	307
[:SENSe]:SPECTrum:AVERAGE:CLEAR	308
[:SENSe]:SPECTrum:AVERAGE:COUNT <integer>	309
[:SENSe]:SPECTrum:AVERAGE:COUNT?	309
[:SENSe]:SPECTrum:AVERAGE:TCONTROL EXPONENTIAL REPEAT	309
[:SENSe]:SPECTrum:AVERAGE:TCONTROL?	309
[:SENSe]:SPECTrum:AVERAGE:TYPE LOG MAXIMUM MINIMUM RMS SCALAR	310
[:SENSe]:SPECTrum:AVERAGE:TYPE?	310
[:SENSe]:SPECTrum:AVERAGE[:STATE] OFF ON 0 1	309
[:SENSe]:SPECTrum:AVERAGE[:STATE]?	309
[:SENSe]:SPECTrum:BANDWIDTH BWIDTH:IF: AUTO OFF ON 0 1	310

[[:SENSe]:SPECTrum:BANDwidth BWIDth:IF:AUTO?	310
[[:SENSe]:SPECTrum:BANDwidth BWIDth:IF:FLATness OFF ON 0 1.....	311
[[:SENSe]:SPECTrum:BANDwidth BWIDth:IF:FLATness?	311
[[:SENSe]:SPECTrum:BANDwidth BWIDth:PADC OFF ON 0 1	311
[[:SENSe]:SPECTrum:BANDwidth BWIDth:PADC?	311
[[:SENSe]:SPECTrum:BANDwidth BWIDth:PFFT:TYPE FLAT GAUSSian.....	312
[[:SENSe]:SPECTrum:BANDwidth BWIDth:PFFT:TYPE?	312
[[:SENSe]:SPECTrum:BANDwidth BWIDth:PFFT[:SIZE] <freq>	311
[[:SENSe]:SPECTrum:BANDwidth BWIDth:PFFT[:SIZE]?	311
[[:SENSe]:SPECTrum:BANDwidth BWIDth[:RESolution] <freq>	312
[[:SENSe]:SPECTrum:BANDwidth BWIDth[:RESolution]:AUTO OFF ON 0 1	313
[[:SENSe]:SPECTrum:BANDwidth BWIDth[:RESolution]:AUTO?.....	313
[[:SENSe]:SPECTrum:BANDwidth BWIDth[:RESolution]?	312
[[:SENSe]:SPECTrum:DECimate[:FACTor] <integer>	314
[[:SENSe]:SPECTrum:DECimate[:FACTor]?	314
[[:SENSe]:SPECTrum:FFT:LENGth <integer>	314
[[:SENSe]:SPECTrum:FFT:LENGth:AUTO OFF ON 0 1	315
[[:SENSe]:SPECTrum:FFT:LENGth:AUTO?	315
[[:SENSe]:SPECTrum:FFT:LENGth?	314
[[:SENSe]:SPECTrum:FFT:RBWPoints <real>	315
[[:SENSe]:SPECTrum:FFT:RBWPoints?	315
[[:SENSe]:SPECTrum:FFT:WINDow:DELay <real>.....	315
[[:SENSe]:SPECTrum:FFT:WINDow:DELay?	315
[[:SENSe]:SPECTrum:FFT:WINDow:LENGth <integer>.....	316
[[:SENSe]:SPECTrum:FFT:WINDow:LENGth?.....	316
[[:SENSe]:SPECTrum:FFT:WINDow[:TYPE] BH4Tap BLACKman FLATtop GAUSSian HAM- Ming HANNing KB70 KB90 KB110 UNIFORM	316
[[:SENSe]:SPECTrum:FFT:WINDow[:TYPE]?.....	316
[[:SENSe]:SPECTrum:FREQuency:SPAN <freq>	317
[[:SENSe]:SPECTrum:FREQuency:SPAN?	317
[[:SENSe]:SPECTrum:SWEep:TIME:AUTO OFF ON 0 1	318
[[:SENSe]:SPECTrum:SWEep:TIME:AUTO	318
[[:SENSe]:SPECTrum:SWEep:TIME?	317
[[:SENSe]:SPECTrum:SWEep:TIME[:VALue] <time>	317

[:SENSe]:SPEctrum:TRIGger:SOURce EXTernal[1] EXTernal2 FRAME IF LINE IMMEDIATE RFBurst	318
[:SENSe]:SPEctrum:TRIGger:SOURce?	318
[:SENSe]:TSPur:AVERage:COUNt <integer>	320
[:SENSe]:TSPur:AVERage:COUNt?	320
[:SENSe]:TSPur:AVERage:TCONtrol EXPonential REPEAT	320
[:SENSe]:TSPur:AVERage:TCONtrol?	320
[:SENSe]:TSPur:AVERage:TYPE LOG MAXimum RMS	321
[:SENSe]:TSPur:AVERage:TYPE?	321
[:SENSe]:TSPur:AVERage[:STATe] OFF ON 0 1	320
[:SENSe]:TSPur:AVERage[:STATe]?	320
[:SENSe]:TSPur:TYPE EXAMine FULL	321
[:SENSe]:TSPur:TYPE?	321
[:SENSe]:TXPower:AVERage:COUNt <integer>	322
[:SENSe]:TXPower:AVERage:COUNt?	322
[:SENSe]:TXPower:AVERage:TCONtrol EXPonential REPEAT	322
[:SENSe]:TXPower:AVERage:TCONtrol?	322
[:SENSe]:TXPower:AVERage:TYPE	323
[:SENSe]:TXPower:AVERage:TYPE?	323
[:SENSe]:TXPower:AVERage[:STATe] OFF ON 0 1	322
[:SENSe]:TXPower:AVERage[:STATe]?	322
[:SENSe]:TXPower:BANDwidth BWIDth[:RESolution] <freq>	323
[:SENSe]:TXPower:BANDwidth BWIDth[:RESolution]:TYPE FLAT GAUSSian	323
[:SENSe]:TXPower:BANDwidth BWIDth[:RESolution]:TYPE?	323
[:SENSe]:TXPower:BANDwidth BWIDth[:RESolution]?	323
[:SENSe]:TXPower:SWEep:TIME <integer>	324
[:SENSe]:TXPower:SWEep:TIME?	324
[:SENSe]:TXPower:THReshold <power>	324
[:SENSe]:TXPower:THReshold:TYPE ABSolute RELative	325
[:SENSe]:TXPower:THReshold:TYPE?	325
[:SENSe]:TXPower:THReshold?	324
[:SENSe]:TXPower:TRIGger:SOURce EXTernal[1] EXTernal2 IF IMMEDIATE RFBurst	325
[:SENSe]:TXPower:TRIGger:SOURce?	325
[:SENSe]:WAVEform:ACQuisition:PACKing AUTO LONG MEDIUM SHORT	326

[[:SENSe]:WAVeform:ACQuiStion:PACKing?	326
[[:SENSe]:WAVeform:ADC:DITHer[:STATe] OFF ON 0 1	326
[[:SENSe]:WAVeform:ADC:DITHer[:STATe]?	326
[[:SENSe]:WAVeform:ADC:FILTer[:STATe] OFF ON 0 1	326
[[:SENSe]:WAVeform:ADC:FILTer[:STATe]?	326
[[:SENSe]:WAVeform:ADC:RANGe AUTO APEak APLock GROund NONE P0 P6 P12 P18	327
[[:SENSe]:WAVeform:ADC:RANGe?	327
[[:SENSe]:WAVeform:APERture?	327
[[:SENSe]:WAVeform:AVERage:COUNT <integer>	327
[[:SENSe]:WAVeform:AVERage:COUNT?	327
[[:SENSe]:WAVeform:AVERage:TCONtrol EXPonential REPEAT	328
[[:SENSe]:WAVeform:AVERage:TCONtrol?	328
[[:SENSe]:WAVeform:AVERage:TYPE LOG MAXimum MINimum RMS SCALar	329
[[:SENSe]:WAVeform:AVERage:TYPE?	329
[[:SENSe]:WAVeform:AVERage[:STATe] OFF ON 0 1	328
[[:SENSe]:WAVeform:AVERage[:STATe]?	328
[[:SENSe]:WAVeform:BANDwidth:RESolution]:ACTual?	329
[[:SENSe]:WAVeform:BANDwidth BWIDth[:RESolution] <freq>	329
[[:SENSe]:WAVeform:BANDwidth BWIDth[:RESolution]:TYPE FLATtop GAUSSian	330
[[:SENSe]:WAVeform:BANDwidth BWIDth[:RESolution]:TYPE?	330
[[:SENSe]:WAVeform:BANDwidth BWIDth[:RESolution]?	329
[[:SENSe]:WAVeform:DECimate:STATe OFF ON 0 1	331
[[:SENSe]:WAVeform:DECimate:STATe?	331
[[:SENSe]:WAVeform:DECimate[:FACTor] <integer>	330
[[:SENSe]:WAVeform:DECimate[:FACTor]?	330
[[:SENSe]:WAVeform:SWEep:TIME <time>	331
[[:SENSe]:WAVeform:SWEep:TIME?	331
[[:SENSe]:WAVeform:TRIGger:SOURce EXTernal[1] EXTernal2 FRAMe IF IMMEDIATE LINE RFBurst	331
[[:SENSe]:WAVeform:TRIGger:SOURce?	331

1 Understanding GSM and EDGE

What are GSM and EDGE?

The Global System for Mobile communication (GSM) digital communications standard defines a voice and data over-air interface between a mobile radio and the system infrastructure. This standard was designed as the basis for a digital cellular radio communications system. A base station control center (BSC) is linked to multiple base transceiver station (BTS) sites which provide the required coverage.

EDGE (Enhanced Data Rates for GSM Evolution) enhances the GSM standard by implementing a new modulation format and filtering designed to provide higher data rates in the same spectrum. EDGE and GSM signals can be transmitted on the same frequency, occupying different timeslots, and both use existing GSM equipment. EDGE has also been adopted as the basis for IS-136HS.

The GSM digital communications standard employs an 8:1 Time Division Multiple Access (TDMA) allowing eight channels to use one carrier frequency simultaneously. The 270.833 kbits/second raw bit rate is modulated on the RF carrier using Gaussian Minimum Shift Keying (GMSK).

The standard includes multiple traffic channels, a control channel, and a cell broadcast channel. The GSM specification defines a channel spacing of 200 kHz.

GSM 900, GSM 450, GSM 480, GSM 850, DCS 1800, and PCS 1900 are GSM-defined frequency bands. The term GSM 900 is used for any GSM or EDGE system operating in the 900 MHz band, which includes P-GSM, E-GSM, and R-GSM. Primary (or standard) GSM 900 band (P-GSM) is the original GSM band. Extended GSM 900 band (E-GSM) includes all the P-GSM band plus an additional 50 channels. Railway GSM 900 band (R-GSM) includes all the E-GSM band plus additional channels.

GSM 450, GSM 480, GSM 700, and GSM 850 are additional GSM-defined frequency bands, that provide additional bandwidth availability.

DCS 1800 is an adaptation of GSM 900, created to allow for smaller cell sizes for higher system capacity. PCS 1900 is intended to be identical to DCS 1800 except for frequency allocation and power levels. The term GSM 1800 is sometimes used for DCS 1800, and the term GSM 1900 is sometimes used for PCS 1900. For specifics on the bands, refer to [Table 1-1](#).

Table 1-1 EDGE and GSM Band Data

	P-GSM (GSM 900)	E-GSM (GSM 900)	R-GSM (GSM 900)	DCS 1800 (GSM 1800)	PCS 1900 (GSM 1900)	GSM 450	GSM 480	GSM 700	GSM 850
Uplink (MS Transmit)	890 to 915 MHz	880 to 915 MHz	876 to 915 MHz	1710 to 1785 MHz	1850 to 1910 MHz	450.4 to 457.6 MHz	478.8 to 486 MHz	777 to 792 MHz	824 to 849 MHz
Downlink (BTS Transmit)	935 to 960 MHz	925 to 960 MHz	921 to 960 MHz	1805 to 1880 MHz	1930 to 1990 MHz	460.4 to 467.6 MHz	488.8 to 496 MHz	747 to 762 MHz	869 to 894 MHz
Range (ARFCN)	1 to 124	0 to 124 and 975 to 1023	1 to 124 and 955 to 1023	512 to 885	512 to 810	259 to 293	306 to 340	438 to 511	128 to 251
TX/RX Spacing (Freq.)	45 MHz	45 MHz	45 MHz	95 MHz	80 MHz	45 MHz	45 MHz	30 MHz	45 MHz
TX/RX Spacing (Time)	3 timeslots	3 timeslots	3 timeslots	3 timeslots	3 timeslots	3 timeslots	3 timeslots	3 timeslots	3 timeslots
Modulation Data Rate GMSK(kbits/s) 8PSK (kbits/s):	270.833 812.499	270.833 812.499	270.833 812.499	270.833 812.499	270.833 812.499	270.833 812.499	270.833 812.499	270.833 812.499	270.833 812.499
Frame Period	4.615 ms	4.615 ms	4.615 ms	4.615 ms	4.615 ms	4.615 ms	4.615 ms	4.615 ms	4.615 ms
Timeslot Period	576.9 μ s	576.9 μ s	576.9 μ s	576.9 μ s	576.9 μ s	576.9 μ s	576.9 μ s	576.9 μ s	576.9 μ s
GSM Bit and Symbol Period	3.692 μ s	3.692 μ s	3.692 μ s	3.692 μ s	3.692 μ s	3.692 μ s	3.692 μ s	3.692 μ s	3.692 μ s
EDGE Symbol Period	3.692 μ s	3.692 μ s	3.692 μ s	3.692 μ s	3.692 μ s	3.692 μ s	3.692 μ s	3.692 μ s	3.692 μ s
Modulation GSM EDGE	0.3 GMSK 3 π /8 8PSK	0.3 GMSK 3 π /8 8PSK	0.3 GMSK 3 π /8 8PSK	0.3 GMSK 3 π /8 8PSK	0.3 GMSK 3 π /8 8PSK	0.3 GMSK 3 π /8 8PSK	0.3 GMSK 3 π /8 8PSK	0.3 GMSK 3 π /8 8PSK	0.3 GMSK 3 π /8 8PSK
Channel Spacing	200 kHz	200 kHz	200 kHz	200 kHz	200 kHz	200 kHz	200 kHz	200 kHz	200 kHz
TDMA Mux	8	8	8	8	8	8	8	8	8
Voice Coder Bit Rate	13 kbits/s	13 kbits/s, 5.6 kbits/s	13 kbits/s	13 kbits/s	13 kbits/s	13 kbits/s	13 kbits/s	13 kbits/s	13 kbits/s

The framing structure for GSM and EDGE measurements is based on a hierarchical system consisting of timeslots, TDMA frames, multiframes, superframes, and hyperframes. One timeslot consists of 156.25 (157) symbol periods including tail, training sequence, encryption, guard time, and data bits. Eight of these timeslots make up one TDMA frame. Either 26 or 51 TDMA frames make up one multiframe. Frames 13 and 26 in the 26 frame multiframe are dedicated to control channel signaling. For more detail about timeslots see [“Timeslots” on page 31](#).

What Does the Agilent E4406A VSA Do?

This instrument makes measurements that conform to the ETSI EN 300 910 (GSM 05.05), ETSI EN 300 607.1, (GSM 11.10-1), ETSI EN 301 087 (GSM 11.21), and ANSI J-STD-007 specifications.

These documents define complex, multi-part measurements used to maintain an interference-free environment. For example, the documents include measuring the power of a carrier. The instrument automatically makes these measurements using the measurement methods and limits defined in the standards. The detailed results displayed by the measurements allow you to analyze GSM and EDGE system performance. You may alter the measurement parameters for specialized analysis.

This instrument was primarily developed for making measurements on digital transmission carriers. These measurements can help determine if a GSM transmitter is working correctly. The instrument is capable of measuring the continuous carrier of a base station transmitter.

For infrastructure test, the instrument can test base station transmitters in a non-interfering manner through use of a coupler or power splitter.

This instrument makes the following measurements:

- Transmit Power
- GMSK Power vs. Time
- GMSK Phase and Frequency Error
- GMSK Output RF Spectrum (ORFS)
- GMSK Tx Band Spur
- EDGE Power vs. Time
- EDGE Error Vector Magnitude (EVM)
- EDGE Output RF Spectrum (ORFS)
- EDGE Tx Band Spur
- Spectrum (Frequency Domain)
- Waveform (Time Domain)

EDGE and GSM Measurements

Transmit Power – Verifies in-channel power for GSM and EDGE systems. This measurement ensures that dynamic power control is optimized, over all system interference is minimized, and mobile station battery life is maximized. This measurement can be used both for GMSK and EDGE signals.

Power vs. Time – Verifies that the transmitter output power has the correct amplitude, shape, and timing for the GSM or EDGE format. GMSK and EDGE versions of this measurement are available.

Output RF Spectrum (ORFS) – Verifies that the modulation, wideband noise, and power level switching spectra are within limits and do not produce significant interference in the adjacent base transceiver station (BTS) channels. GMSK and EDGE versions of this measurement are available.

Tx Band Spur – Verifies that the transmitter does not transmit undesirable energy into the transmit band. This energy may cause interference for other users of the GSM system. GMSK and EDGE versions of this measurement are available.

Phase and Frequency – Verifies modulation quality of the 0.3 GMSK signal for GSM systems. The modulation quality indicates the carrier to noise performance of the system, which is critical for mobiles with low signal levels, at the edge of a cell, or under difficult fading or Doppler conditions.

Error Vector Magnitude (EVM) – Provides a measure of modulation accuracy. The EDGE 8 PSK modulation pattern uses a rotation of $3\pi/8$ radians to avoid zero crossing, thus providing a margin of linearity relief for amplifier performance. This is an EDGE only measurement.

Basic Measurements

Spectrum – Provides spectrum analysis capability similar to a swept tuned analyzer. The spectrum measurement is FFT (Fast Fourier Transform) based.

Waveform – Enables you to view waveforms in the time domain. This measurement provides fast zero span functionality which is a crucial feature of traditional spectrum analyzers.

Frequently Used Terms

Mobile Stations and Base Transceiver Stations

The cellular system includes the following:

- Base transceiver stations, referred to as BTS
(frequency ranges dependent on the standard; refer to [Table 1-1 on page 27](#))
- Mobile stations, referred to as MS
(frequency ranges dependent on the standard; refer to [Table 1-1 on page 27](#))

Uplink and Downlink

Uplink is defined as the path from the mobile station to the base transceiver station. Downlink is the path from the base transceiver station to the mobile station.

ARFCN

An ARFCN is the Absolute Radio Frequency Channel Number used in EDGE and GSM systems. Each RF channel is shared by up to eight mobile stations using Time Division Multiple Access (TDMA). The ARFCN is an integer (in a range dependent on the chosen standard, refer to [Table 1-1 on page 27](#)) which designates the carrier frequency.

Timeslots

EDGE and GSM use Time Division Multiple Access (TDMA) which divides each RF channel into eight individual timeslots, thus allowing eight users to share a single carrier frequency. Users are synchronized to transmit in series, each in their assigned timeslot. A user may only transmit every 4.62 ms during their timeslot which is 577 μ s long. The eight timeslots are numbered 0 to 7. The 4.62 ms required to cycle through all eight timeslots is called a frame.

In a GSM signal each 577 μ s timeslot has a length of 156.25 bit periods, which consists of 148 data bits and 8.25 guard bits.

For an EDGE signal each 577 μ s timeslot has a length of 156.25 symbol periods, which consist of 142 data symbols of 3 bits each, 8.25 guard symbols of 3 bits each, and 6 “tail bit” symbols of 3 bits each, for a total of 426 data bits, 18 “tail bits” and 24.75 guard bits. The same frame length of 4.62 ms is required to cycle through the frame.

In a TDMA system, the shape and timing of each transmitted burst must be controlled carefully to avoid overlapping timeslots.

Other Sources of Measurement Information

Additional measurement application information is available through your local Agilent Technologies sales and service office. The following application notes treat digital communications measurements in much greater detail than discussed in this measurement guide.

- Application Note 1298
Digital Modulation in Communications Systems - An Introduction
part number 5965-7160E
- Application Note 1312
Understanding GSM Transmitter Measurements for Base
Transceiver Stations and Mobile Stations
part number 5966-2833E

Instrument Updates at www.agilent.com

These web locations can be used to access the latest information about the instrument, including the latest firmware version.

www.agilent.com/find/vsa

www.agilent.com/find/psa

2 **Setting Up the Mode**

Accessing the Mode

At initial power up, the transmitter tester will come up in the Basic mode, with the Spectrum (Frequency Domain) measurement selected and the Measure menu displayed.

To access the GSM measurement personality, press the **MODE** key and select the **GSM** key.

To access the measurement personality that includes EDGE and GSM, press the **MODE** key and select the **EDGE w/GSM** key.

To access the measurement personality that includes EDGE and GSM, press the **MODE** key and select the **GSM w/EDGE** key.

If you want to set the mode to a known factory default state, press **Preset**. This will preset the mode setup and all of the measurements to the factory default parameters.

You may want to install a new personality, reinstall a personality that you have previously uninstalled, or uninstall a personality option. Instructions can be found in “Installing Optional Measurement Personalities” later in this chapter.

Mode settings are persistent. When you switch from one mode to another mode, the settings you have chosen for the modes will remain active until you change them. This allows you to switch back and forth between modes without having to reset settings each time. Presetting the instrument or powering the instrument off and on will return all mode settings to their default values.

Making a Measurement

This instrument enables you to make a wide variety of measurements on digital communications equipment using the **Basic Mode** measurement capabilities. It also has optional measurement personalities that make measurements based on established industry standards.

To set up the instrument to make measurements, you need to:

1. Press **MODE** to select a personality which corresponds to a digital communications format, like cdma2000, W-CDMA, or EDGE. Or use the Basic mode to make measurements on signals with non-standard formats. After selecting the mode, make any required adjustments to the mode settings by pressing **Mode Setup**.
2. Press **Measure** to select a specific measurement to be performed, like ACP, Channel Power, or EVM, and so forth. After selection of your measurement, make any required adjustments to the measurement settings by pressing **Meas Setup**.

Depending on the current settings of **Meas Control**, the instrument will begin making the selected measurements. The resulting data will be shown on the display or available for export.

3. Press **View/Trace** to display the data from the current measurement. Depending on the mode and measurement selected, various graphical and tabular presentations are available.

If you have a problem, and get an error message, see the “If You Have a Problem” section in each measurement description.

The main keys used in the three steps are shown in the table below.

Step	Primary Key	Setup Keys	Related Keys
1. Select & setup a mode	MODE	Mode Setup, Input, FREQUENCY/ Channel	System
2. Select & setup a measurement	MEASURE	Meas Setup	Meas Control, Restart
3. Select & setup a view	View/Trace	SPAN X Scale, AMPLITUDE Y Scale, Display, Next Window, Zoom	File, Save, Print, Print Setup, Marker, Search

A setting may be reset at any time, and will be in effect on the next measurement cycle or View.

Changing the Mode Setup

Numerous settings can be changed at the mode level by pressing the **Mode Setup** key. This will access a menu with the selections listed below. These settings affect all the measurements in the EDGE (with GSM) mode.

Radio

The **Radio** key accesses a menu to select:

- **Band** - Select the GSM band (P-GSM, E-GSM, R-GSM, GSM 450, GSM 480, GSM 700, GSM 850, DCS 1800, or PCS 1900). Refer to the table in the previous section for GSM band data.
- **Device** - Select the device to test BTS (Base Transceiver Station) or MS (Mobile Station).
- **BTS Type** - Select the type of BTS (Base Transceiver Station) to be tested (Normal, Micro, or Pico).
- **Freq Hopping** - Turn frequency hopping on or off. If frequency hopping is turned on, the instrument will ignore the bursts when the frequency is hopped off the selected channel frequency. Thus only valid data is included in the results. Only the Power vs. Time, EDGE EVM, and Phase and Frequency Error measurements can be made on hopping GSM signals.
- **Carrier** - Select the type of carrier to measure (Burst or Continuous). All standards based measurements use a burst carrier. A continuous carrier is used for special measurement needs.

Radio Default Settings	
Band	P-GSM
Device	BTS
BTS Type	Normal
Freq Hopping	Off
Carrier	Burst

Input

The **Input** key accesses a menu to select the following. (You can also access this menu from the front-panel key **Input**.)

- **Input Port** - Choose between **RF**, **I/Q**, **I Only**, **Q Only**, **50 MHz Ref**, and **IF Align**. (You must have option B7C for I and Q inputs.)
- **RF Input Range** - To set the RF input range, choose **Auto** or **Manual**. If **Auto** is chosen, the instrument automatically sets the attenuator based on the power level of the carrier (where the instrument is tuned). If there are multiple carriers present, the total power might overdrive the front end. In this case you need to set the **RF Input Range** to **Manual** and enter the expected **Max Total Pwr**. **Manual** is also used if you want to hold the input attenuation constant (for the best relative power accuracy). For single carriers it is generally recommended to set the **RF Input Range** to **Auto**.
- **Max Total Pwr** - This key is used to set the maximum total power at the UUT (Unit Under Test). This is the maximum expected value of the mean carrier power referenced to the output of the UUT (may include multiple carriers). The **Max Total Pwr** setting is coupled to the **Input Atten** setting. If **RF Input Range** is set to **Auto**, and **Max Total Pwr** is changed, **RF Input Range** is switched to **Manual**.
- **Input Atten** - This key is used to adjust the input attenuator setting. The **Input Atten** setting is coupled to the **Max Total Pwr** setting. The **Input Atten** key reads out the actual hardware value that will be used for the current measurement. If more than one input attenuator value is used in a single measurement, the value used at the carrier frequency will be displayed. If **RF Input Range** is set to **Auto**, and **Input Atten** is changed, **RF Input Range** is switched to **Manual**.

NOTE

The **Max Total Pwr** and **Input Atten** settings are coupled together, so changing the input **Max Total Pwr** setting by x dB changes the **Input Atten** setting by x dB. When you switch to a different measurement, the **Max Total Pwr** setting is kept constant, but the **Input Atten** may change if the two measurements have different mixer margins. Therefore, you can set the input attenuator manually, or you can set it indirectly by specifying the expected maximum power from the UUT.

- **Ext Atten** - Set this to the value of an external attenuator used to reduce the power input for either a BTS or MS under test. This will allow the instrument to display measurement results which will reflect the actual power output of the UUT (Unit Under Test).
- **IF Align Signal** - This key has effect only when **Input Port** is set to **IF Align**. When **IF Align** is activated, the RF path is switched to bring in the same alignment signal that is automatically switched in to perform many alignments. This selection will allow manual adjustment of the alignment signal for diagnostic purposes:

- **Signal Rate** - The signal is modulated by a digital sequence that can be set to 1 of 13 positions (rate 0 through 12) to cause the comb spacing (or pulse timing) of the alignment signal to widen or narrow. At the position of 1 the signal rate is set at its maximum value of 468.75 kHz. This frequency rate value will appear in the softkey label. Each time the position is incremented, the signal rate is halved. For example, at a position of 2 the signal rate is 234.375 kHz.
- **Signal Amptd** key. To modify the signal amplitude you will enter a DAC value between 0 - 4095. The amplitude range is 0 to 50 dB. Incrementing the DAC value increases the amplitude of the signal in a linear fashion, and will be visible on screen. The default DAC value is 500.
- **Signal Type** key. This menu allows you to select a CW (a tone that appears in the center of the IF), comb, or pulse type signal as the IF align signal.

Input Default Settings	
Input Port	RF
RF Input Range	Auto
Max Total Power	-15.00 dBm
Input Atten	0.00 dB
Ext Atten MS	0.00 dB
Ext Atten BTS	0.00 dB
IF Align Signal Rate	0 (= 468.75 kHz)
IF Align Signal Amptd	DAC 500
IF Align Signal Type	CW

Trigger

The **Trigger** key accesses the mode setup menu for the following trigger source menus:

- **RF Burst**
- **Video (Envlp)**
- **Ext Front**
- **Ext Rear**

Pressing one of the trigger source menu keys will access the trigger mode setup menu. This menu is used to set the **Delay**, **Level**, and **Slope** for each trigger source. Note that the actual trigger source is selected separately for each measurement (under the **Meas Setup** key).

Delay - For trigger delay use positive values. For pre-trigger use negative values.

Level - For the **RF Burst** selection, the level is relative to the peak level of the RF signal. For the **Video** selection, the level is the value, in dBm at the RF input, that will cause the trigger. For the **Ext Front** and **Ext Rear** selections, the level range is -5 to +5 volts.

Slope Pos Neg - Choose to trigger off of the leading edge (**Pos**) or the trailing edge (**Neg**) of the burst.

Other keys accessed under the **Trigger** key:

- **Trig Holdoff** - Sets the period of time before the next trigger can occur.
- **Auto Trig** - Acts as a trigger timeout. If no trigger occurs by the specified time, a trigger is automatically generated.
- **Frame Timer** - Accesses the menu to manually control the frame timer:

Period - Sets the period of the frame clock. The default is 4.615385 μ s (1 GSM frame).

Offset - Sets a one-time phase adjustment of the frame clock.

Reset Offset - Resets the display of offset key to 0.

Sync Source - Selects the source used to sync the frame timer (Ext Front, Ext Rear, or Off).

- **RF Sync Delay** - In measurements that detect the GSM "T0", **RF Sync Delay** adjusts the "T0" point. This adjustment does not apply if the **Burst Sync** key is set to **None**, or if it is set to **Training Seq** in the Phase and Frequency Error measurement. The "T0" point is defined as the time point of the transition from bit 13 to bit 14 of the midamble training sequence for a given time slot.
- **Burst Search Threshold** - Sets the threshold level used in the search for EDGE or GSM bursts after data is acquired. This is a relative level based on the peak "on" power.

Trigger Default Settings	
RF Burst	
Delay	0.000 s
Peak Level	-20.00 dB
Slope	Pos
Video	
Delay	0.000 s
Level	-6.00 dBm
Slope	Pos
Ext Front	
Delay	0.000 s
Level	2.00 V
Slope	Pos
Ext Rear	
Delay	0.000 s
Level	2.00 V
Slope	Pos
Trig Holdoff	0.000 s
Auto Trig	100.0 ms Off
Frame Timer	
Period	4.615383 ms
Offset	0.000 s
Reset Offset	Display
Sync Source	Off
RF Sync Delay	0.000 s
Burst Search Threshold	-30.00 dB

Demod (GSM only)

- **Burst Align** - Select the burst alignment between:

GSM - Uses the burst alignment as defined in the GSM specifications.

1/2 Bit Offset - Shifts the burst alignment by 1/2 bit. This selection applies to the Power vs. Time and the Phase and Frequency Error measurements.

Demod Default Settings	
Demod Burst Align	GSM

Changing the Frequency Channel

After selecting the desired mode setup, you will need to select the desired ARFCN, center frequency, BMT frequency, burst type, and TSC (Training Sequence Code). The selections made here will apply to all measurements in the mode. Press the **Frequency Channel** key to access the following menu:

- ARFCN** Allows you to select the desired RF channel to be measured. Refer to the table below for the ARFCN range for a specific GSM band.

- Center Freq** This is the current instrument center frequency. Use this key to input a frequency that corresponds to the desired RF channel to be measured.

- BMT Freq** Allows you to select the Bottom, Middle, or Top frequencies of the GSM selected radio band to be measured. This will automatically select a specific center frequency and ARFCN. Refer to the following table.

Band	Tx Band Edge (MHz)		BOTTOM		MIDDLE		TOP	
	Low	High	Freq (MHz)	ARFCN	Freq (MHz)	ARFCN	Freq (MHz)	ARFCN
P-GSM	935	960	935.200	1	947.600	63	959.800	124
E-GSM	925	960	925.200	975	942.600	38	959.800	124
R-GSM	921	960	921.200	955	940.600	28	959.800	124
DCS 1800	1805	1880	1805.20	512	1842.60	699	1879.80	885
PCS 1900	1930	1990	1930.20	512	1960.00	661	1989.80	810
GSM 450	460.4	467.6	460.600	259	464.000	276	467.400	293
GSM 480	488.8	496.0	489.000	306	492.400	323	495.800	340
GSM 700	747	762	747.2	438	754.6	475	761.8	511
GSM 850	869	894	869.200	128	881.600	190	893.800	251

- Timeslot** Selects which one of the 8 time slots in a frame is active (timeslot 0 is the default, both when set to On and when set to Off). Timeslot is available when **Burst Sync** is either **Training Sequence** or **RF Amptd**; otherwise it is unavailable (greyed out).
- The timeslots are determined by taking the acquired data and dividing it into timeslots 0 to 7. An active timeslot burst must be within approximately 25% of the expected timeslot position, otherwise the instrument may think the burst is an adjacent timeslot and may not detect it. The trigger delay can be used to position the signal if it is not aligned in the timeslots as desired.
- Burst Type** Choose an EDGE or GSM burst type from the following selections:
- **Normal (TCH & CCH)** - Burst length = 142 symbols
This is the default setting for EDGE (with GSM), and should be used for all EDGE burst measurements.
 - **Sync (SCH)** - Burst length = 142 symbols
Use of this Burst Type is usually associated with GSM measurements.
 - **Access (RACH)** - Burst length = 88 symbols
Use of this Burst Type is usually associated with GSM measurements.
- TSC** Allows you to select the Training Sequence Code that determines which burst is to be measured. This key will be unavailable (grayed out) if a burst type other than **Normal** is selected, indicating the standard TSC is used corresponding to the burst type. **Burst Sync** must be set to **Training Sequence**.
- **Auto** - In auto, the measurement is made on the first burst found to have any one of the valid TSCs in the range of 0 to 7. The measurement may be made on various timeslots if more than one timeslot has one of the 8 valid TSCs.
 - **Man** - In manual, the measurement is made on the first burst found to have the selected TSC. TSC numbers in the range of 0 to 7 can be selected. The measurement may be made on various timeslots if more than one timeslot has this same TSC.

Frequency Channel Defaults

When the EDGE (with GSM) mode is selected, the instrument will default to the following settings.

Function	Factory Default Setting
ARFCN	1
Center Frequency	935.200 MHz
Timeslot	0 Off
Burst Type	Normal (TCH & CCH)
TSC (Std)	0 Auto

EDGE and GSM Measurement Key Flow

The key flow diagrams, shown in a hierarchical manner on the following pages, will help the user to grasp the overall functional relationships for the front-panel keys and the softkeys displayed at the extreme right side of the screen. The diagrams are:

- “Mode Setup / Frequency Channel Key Flow” on page 46
- “Transmit Power Key Flow” on page 47
- “GMSK Power vs. Time Key Flow” on page 48
- “GMSK Phase and Frequency Error Key Flow” on page 49
- “GMSK Output RF Spectrum Key Flow” on page 50
- “GMSK Tx Band Spur Key Flow” on page 51
- “EDGE Power vs. Time Key Flow” on page 52
- “EDGE Error Vector Magnitude Key Flow” on page 53
- “EDGE Output RF Spectrum Key Flow (1 of 2)” on page 54
- “EDGE Tx Band Spurs Key Flow” on page 56
- “Spectrum (Freq Domain) Key Flow (1 of 3)” on page 57
- “Waveform (Time Domain) Key Flow (1 of 2)” on page 60

Use the key flow diagrams as follows:

- There are some basic conventions:

View/Trace

An oval represents one of the front-panel keys.

QPSK EVM

This box represents one of the softkeys displayed.

<for EVM>

This represents an explanatory description on its specific key.

Avg Number 10 On|Off

This box represents one of the default condition softkeys displayed. Default conditions are shown as much as possible with underlined parameters or values displayed on those softkey labels.

- Follow the measurement diagram from left to right and top to bottom.
- A single softkey may allow multiple choices. For example; the **Device** softkey reveals two choices, **BTS** or **MS**. The underlined choice is the current state of the instrument. To change choices, press the softkey one time.
- When entering a numeric value of **Frequency**, for example, use the numeric keypad and terminate the entry with the appropriate unit selection from the softkeys displayed.
- When entering a numeric value of **Slot (Std)**, for example, use the numeric keypad and terminate with the **Enter** front-panel key.

Instead of using the numeric keypad to enter a value, it may be easier to use the RPG knob or **Up/Down** keys.

Figure 2-1 Mode Setup / Frequency Channel Key Flow

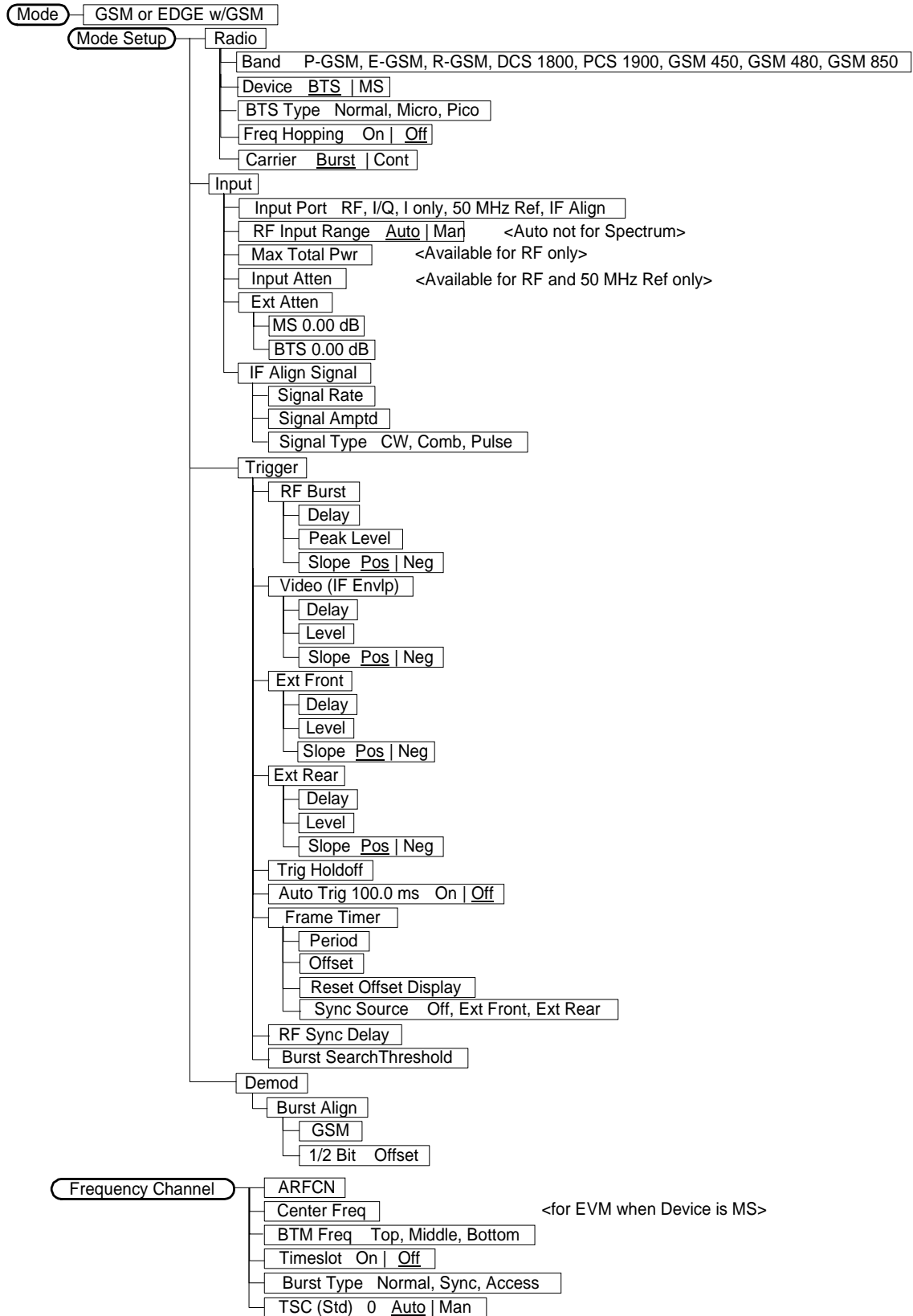

Figure 2-2 Transmit Power Key Flow

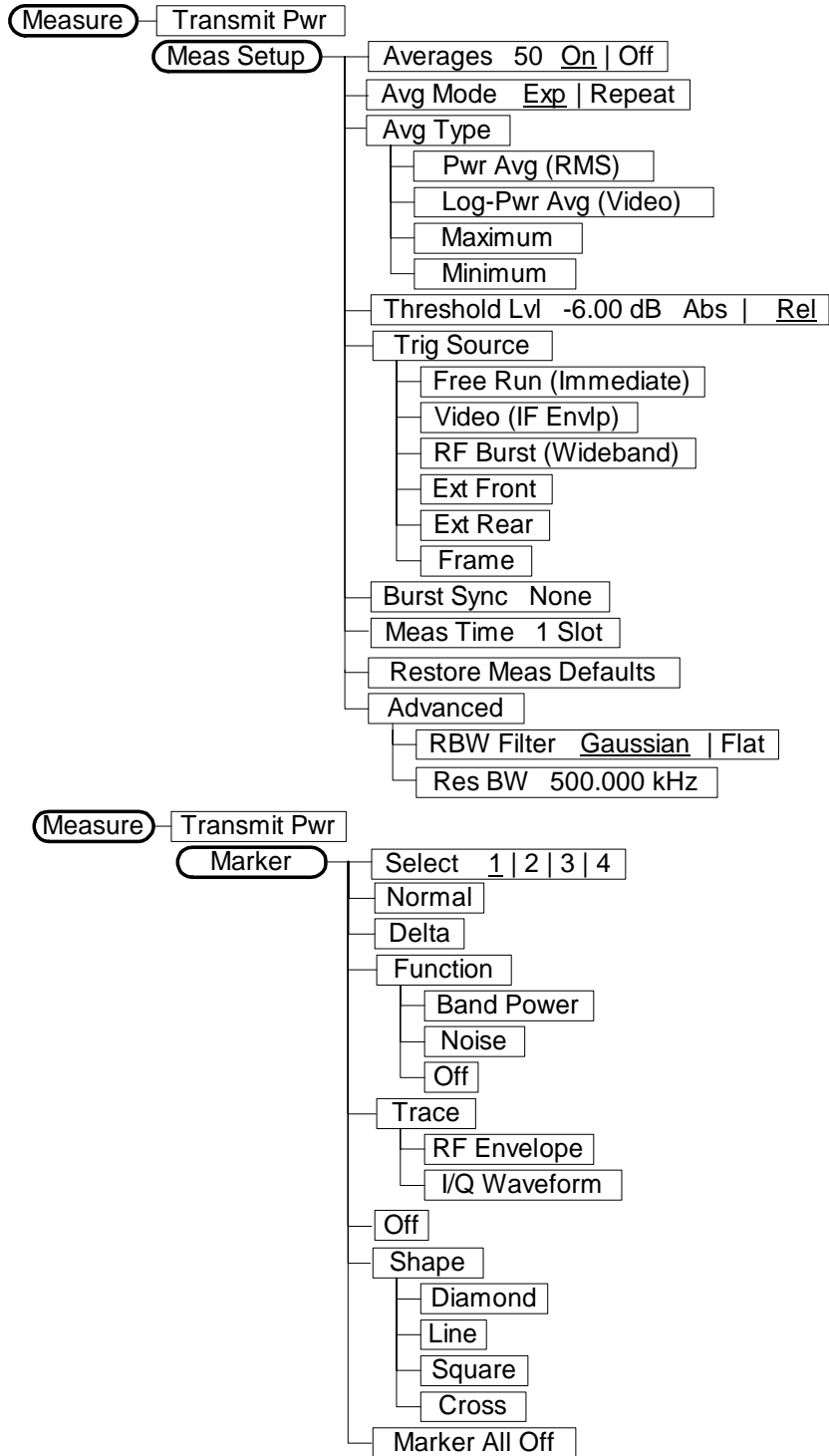
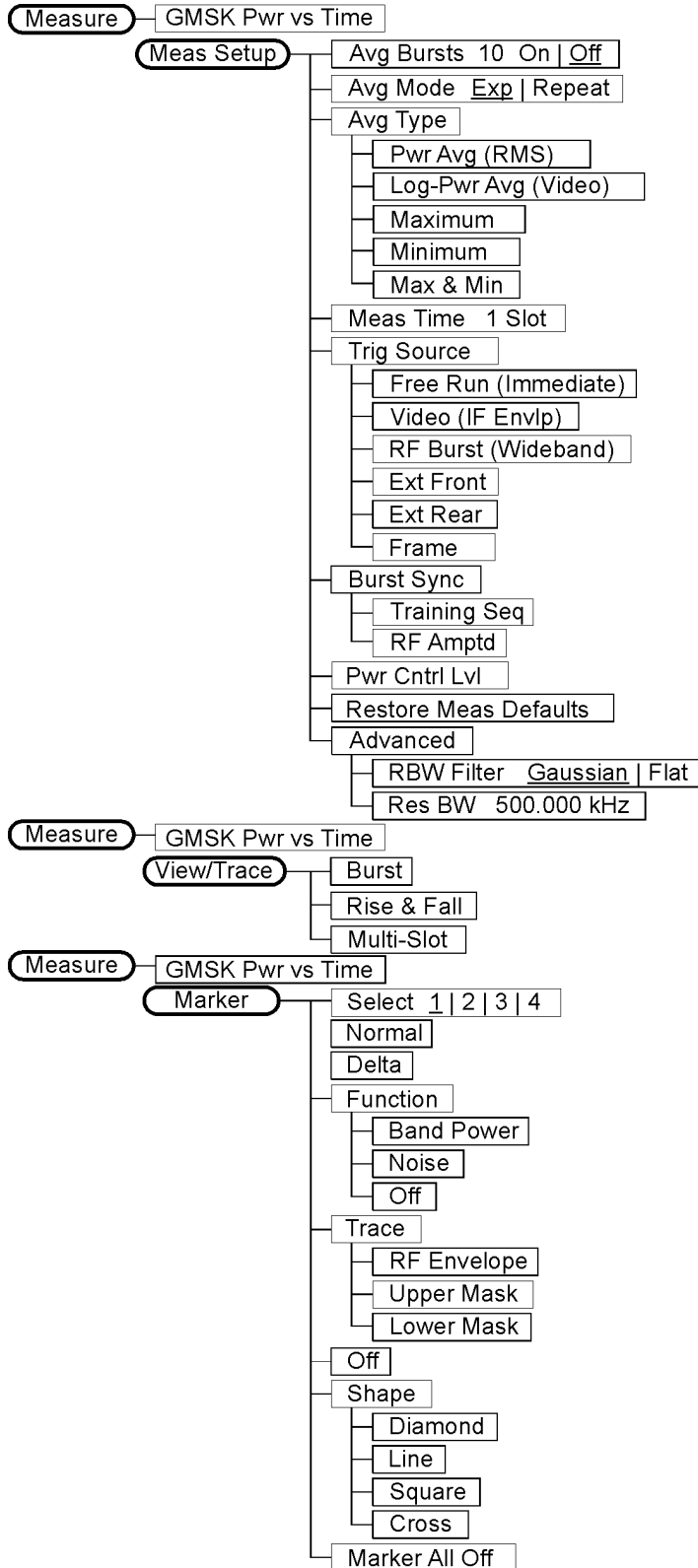
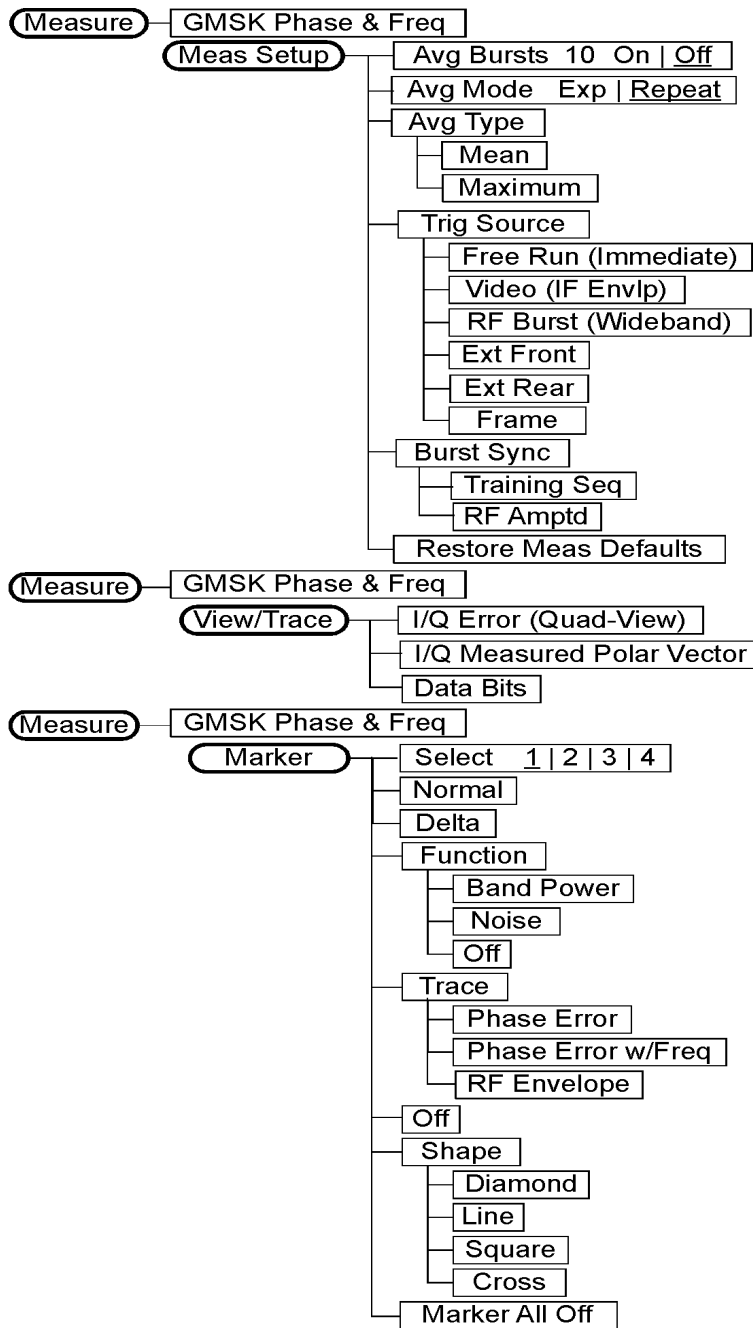

Figure 2-3 **GMSK Power vs. Time Key Flow**



pwrtime

Figure 2-4 **GMSK Phase and Frequency Error Key Flow**



phsefreq

Figure 2-5 **GMSK Output RF Spectrum Key Flow**

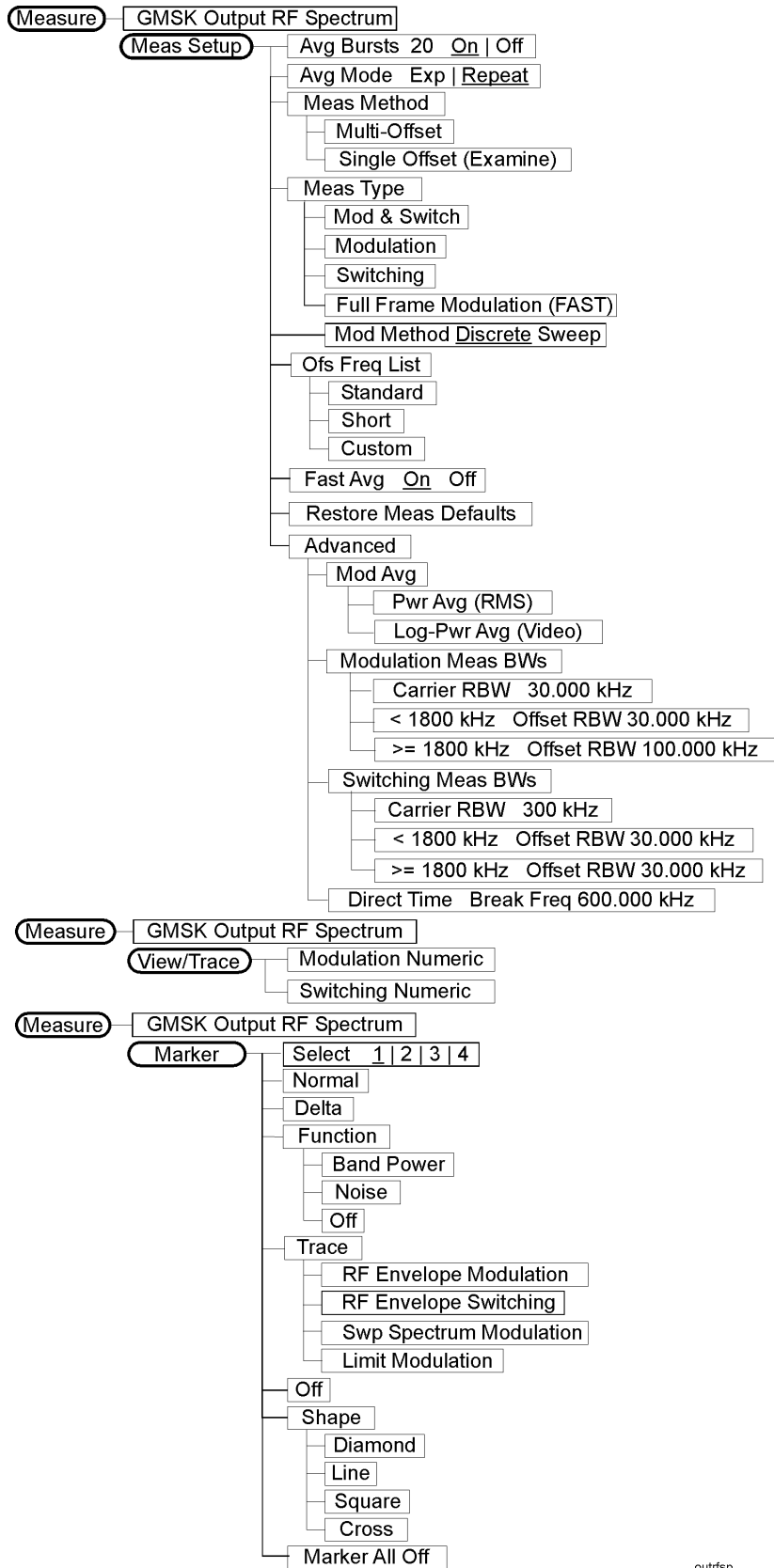

outfosp

Figure 2-6 GMSK Tx Band Spur Key Flow

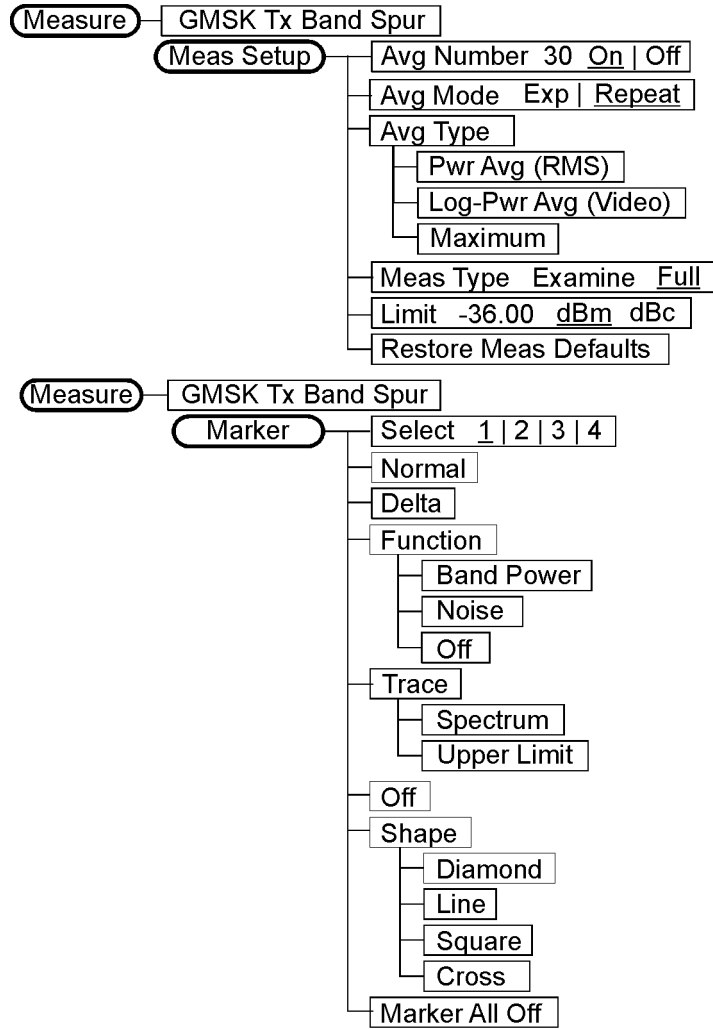

txbandspr_1

Figure 2-7 EDGE Power vs. Time Key Flow

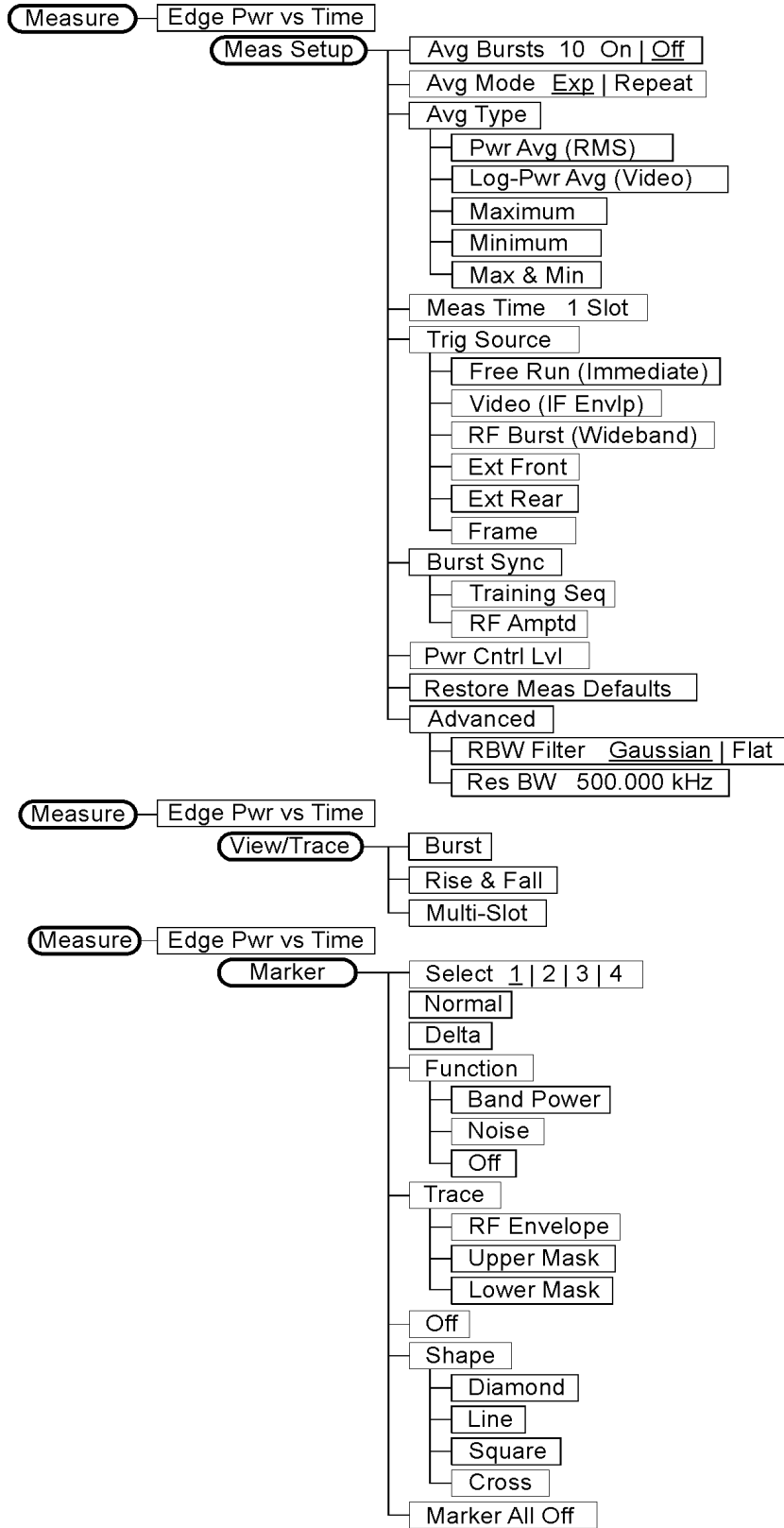

epwrtime

Figure 2-8 EDGE Error Vector Magnitude Key Flow

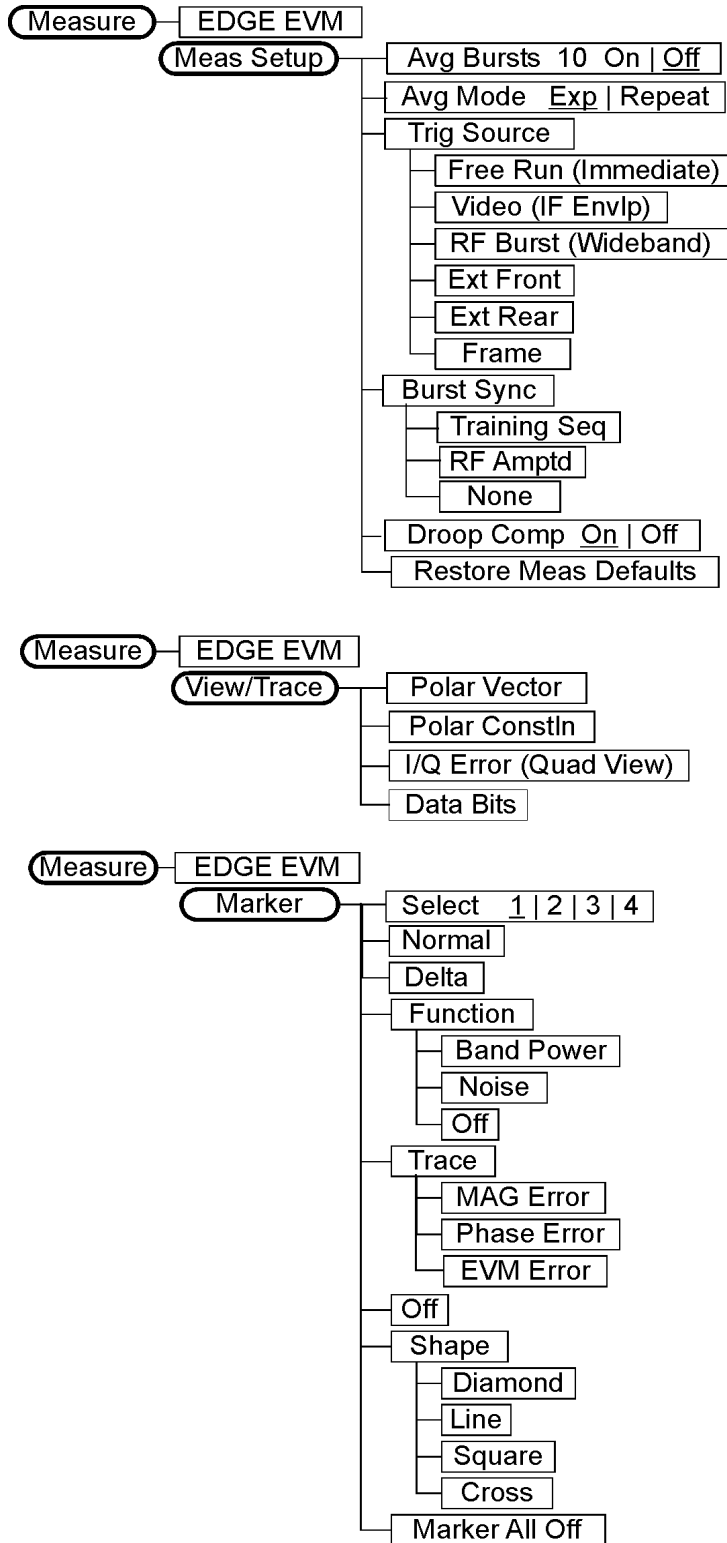
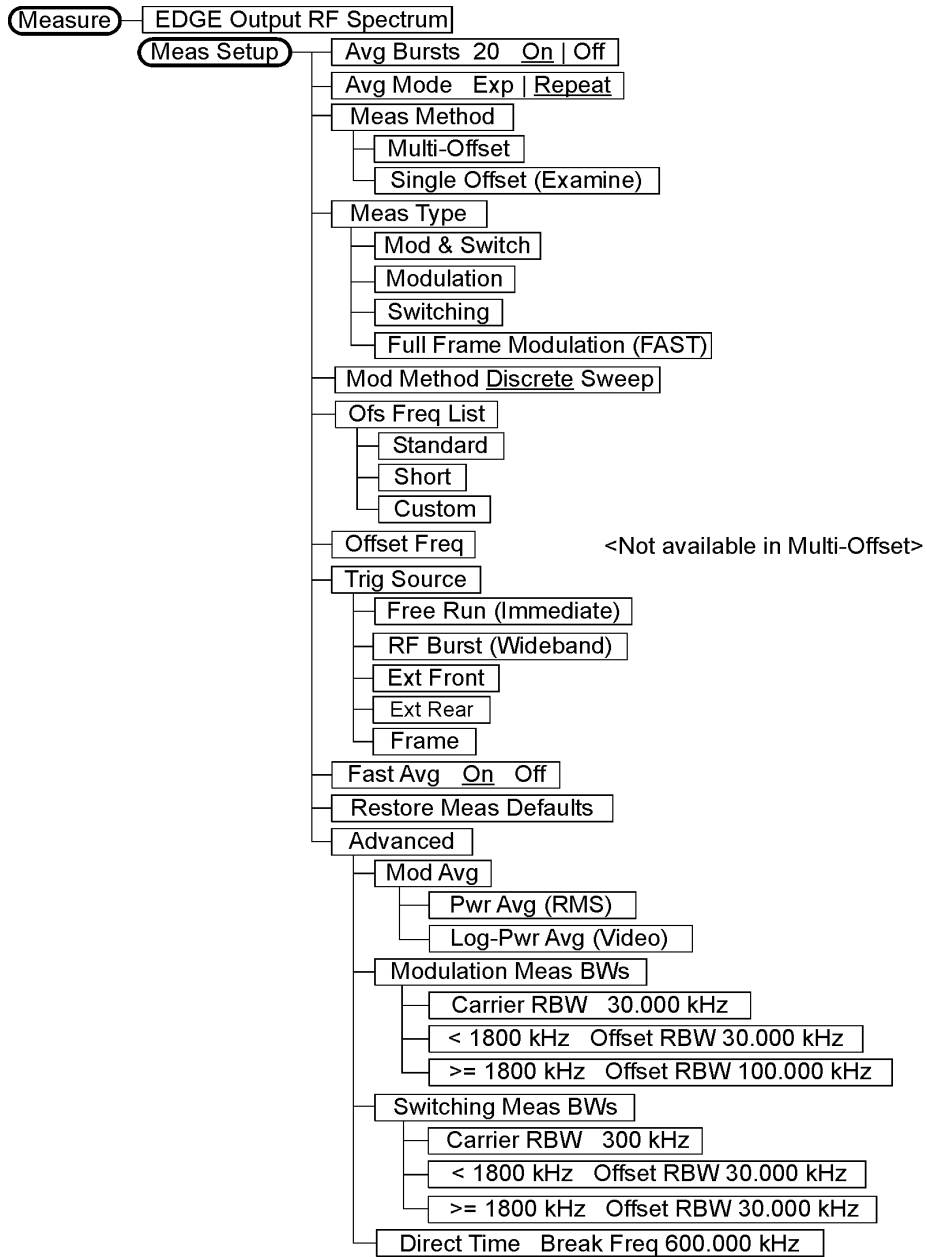
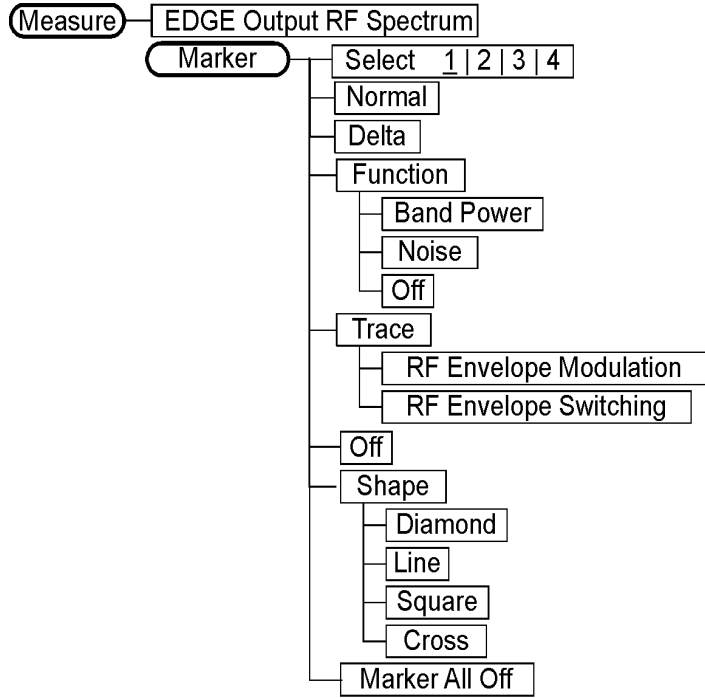

Figure 2-9 EDGE Output RF Spectrum Key Flow (1 of 2)



edgortsa

Figure 2-10 **EDGE ORFS Key Flow (2 of 2)**



edgorfsb

Figure 2-11 EDGE Tx Band Spurs Key Flow

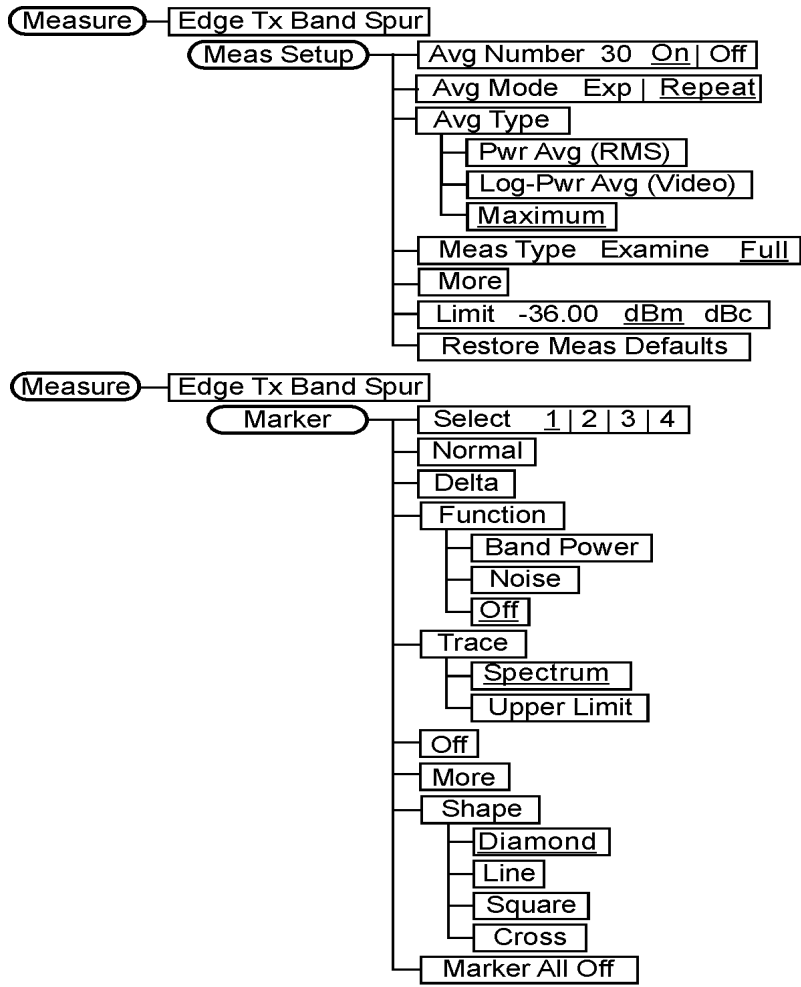

etxbndspr

Figure 2-12 Spectrum (Freq Domain) Key Flow (1 of 3)

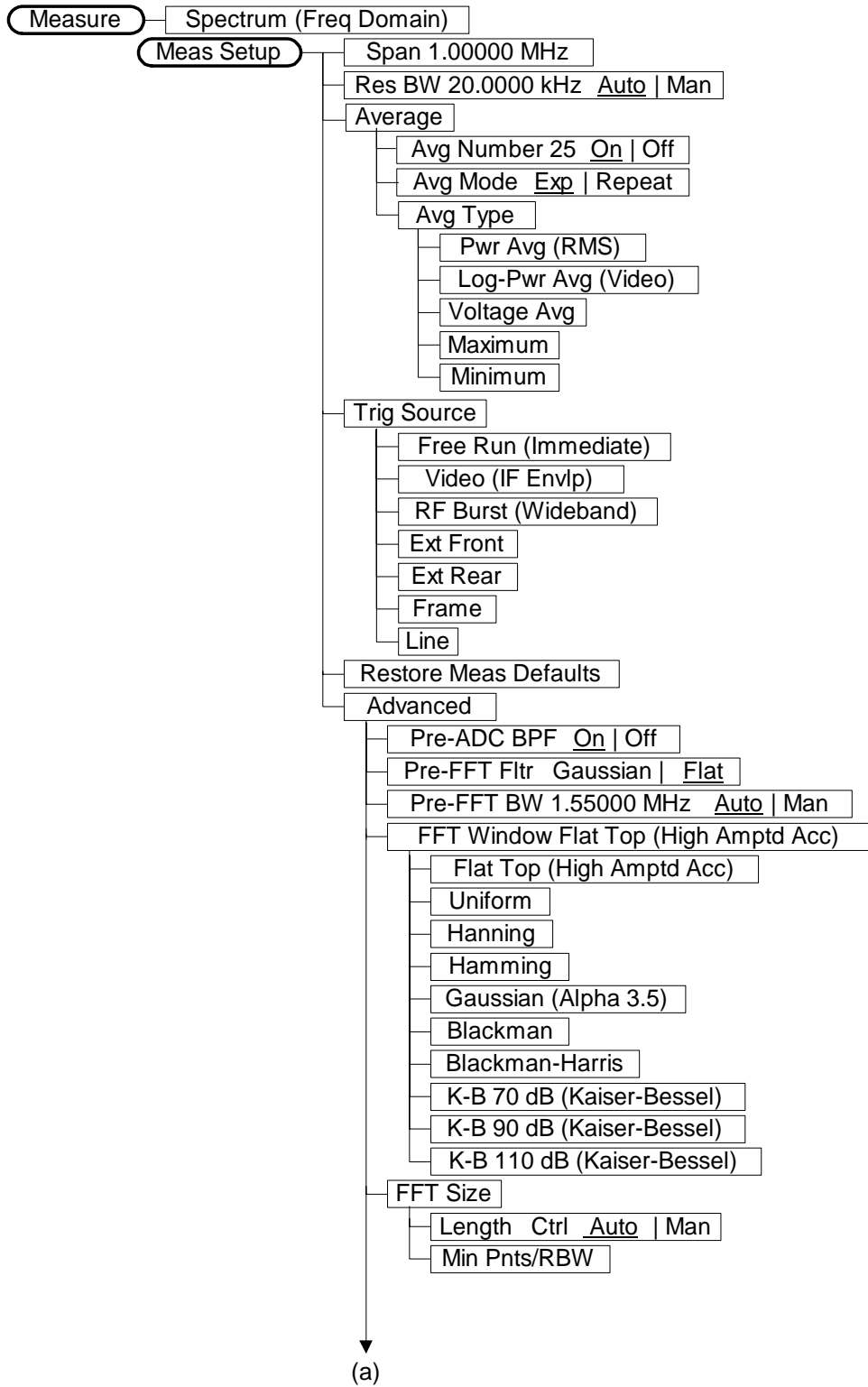

Figure 2-13 Spectrum (Freq Domain) Measurement Key Flow (2 of 3)

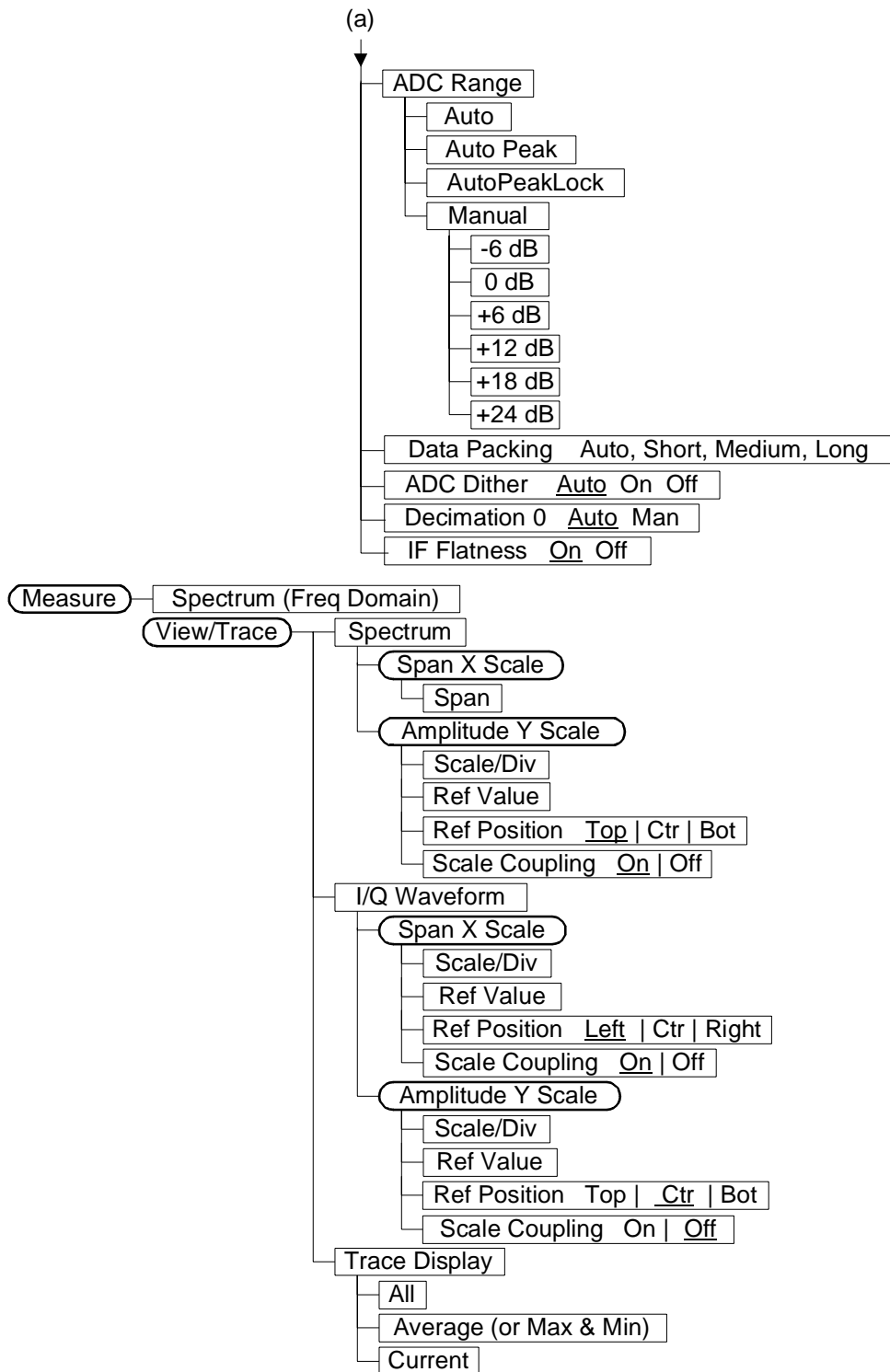

Figure 2-14 Spectrum (Freq Domain) Measurement Key Flow (3 of 3)

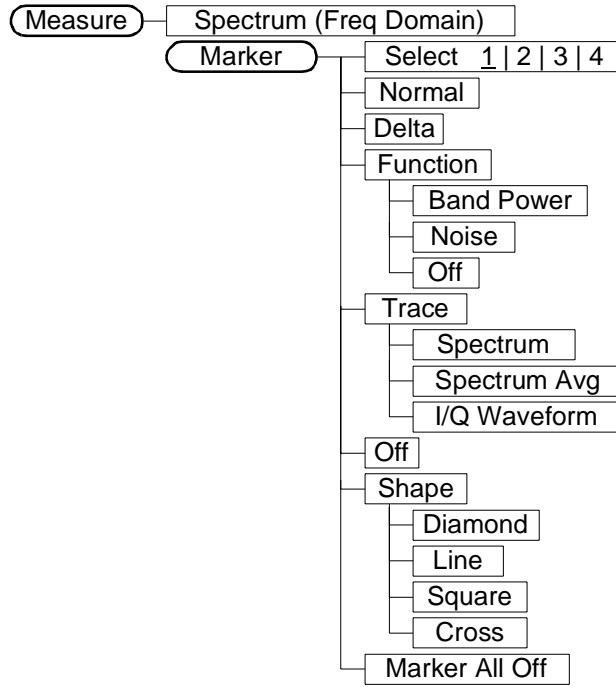

Figure 2-15 **Waveform (Time Domain) Key Flow (1 of 2)**

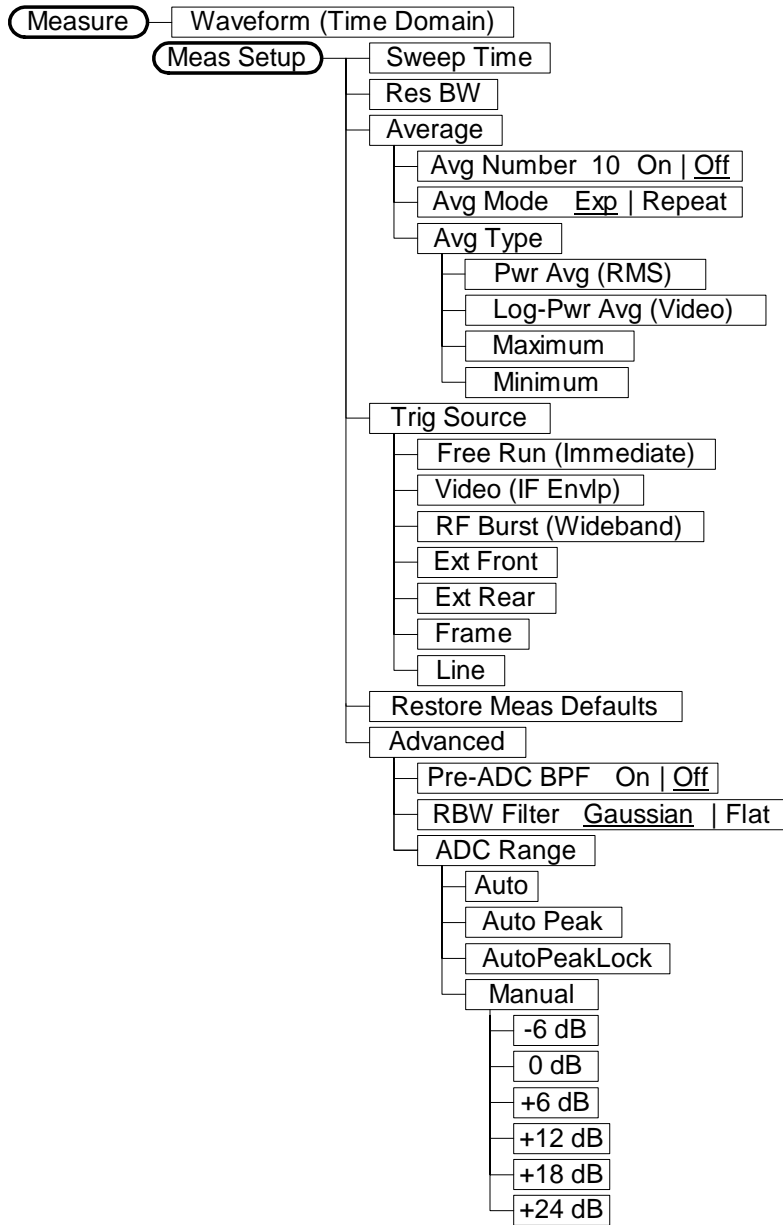
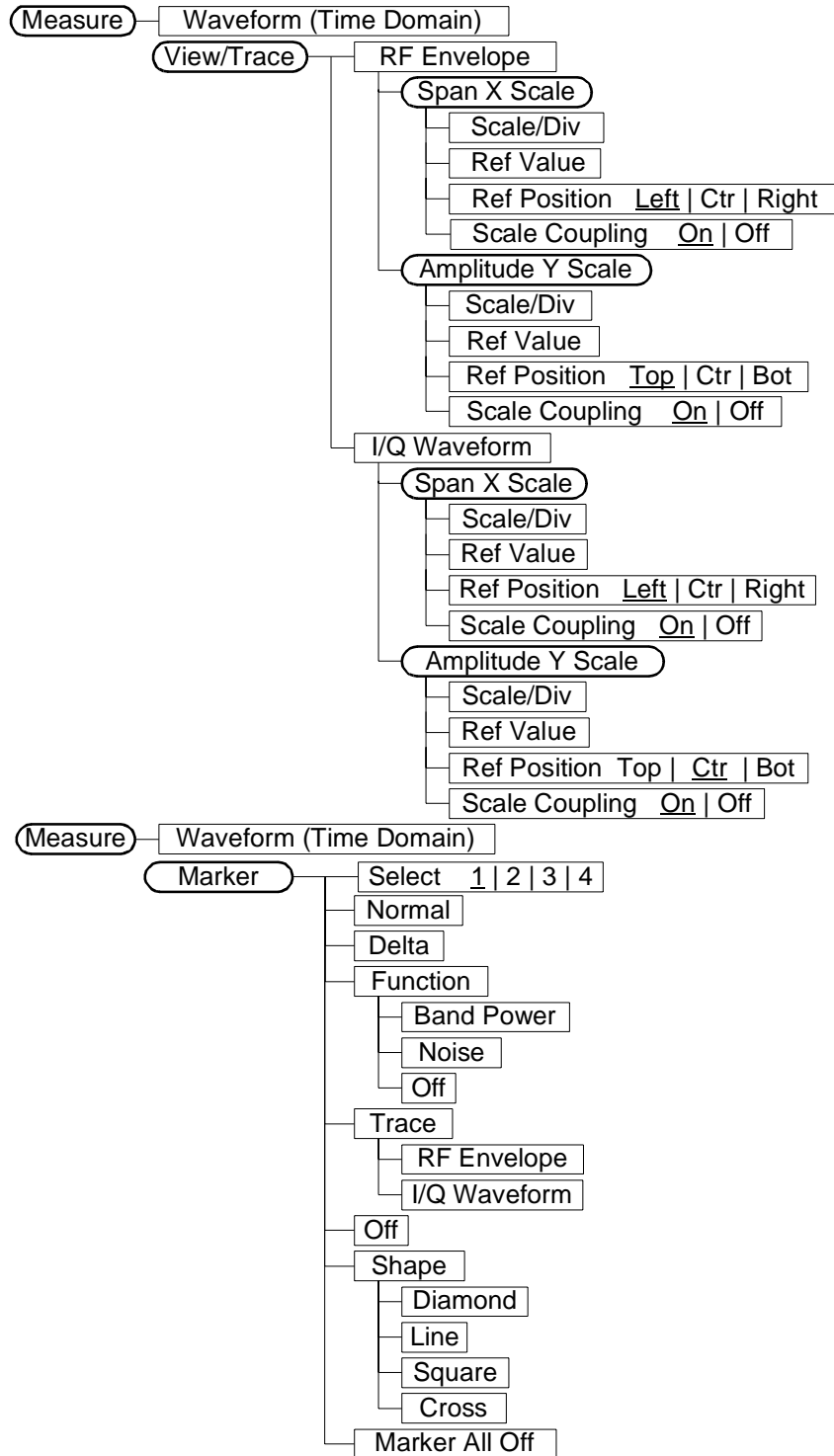

Figure 2-16 Waveform (Time Domain) Measurement Key Flow (2 of 2)



Installing Optional Measurement Personalities

When you install a measurement personality, you follow a two step process.

1. Install the measurement personality firmware into the instrument memory. See “Loading an Optional Measurement Personality” on page 63.
2. Enter a license key number that activates the measurement personality. See “Installing a License Key” on page 64.

Adding additional measurement personalities requires purchasing a retrofit kit for the desired option. The retrofit kit contains the measurement personality firmware and a license key certificate. It documents the license key number that is specific for your option and instrument serial number.

Available Measurement Personality Options

To order a measurement personality option you need the instrument model number, the host ID and the serial number.

Required Information:	Front Panel Key Path:
Model #: E4406A	
Host ID: _____	System, Show System
Instrument Serial Number: _____	System, Show System

Available Personality Options ^a	Option	File Size (VSA Rev: A.05.35)
GSM measurement personality	BAH	2.4 MB
EDGE (with GSM) measurement personality ^b	202	3.3 MB
cdmaOne measurement personality	BAC	2.0 MB
NADC measurement personalities (sold with PDC)	BAE	1.3 MB

Available Personality Options ^a	Option	File Size (VSA Rev: A.05.35)
PDC measurement personalities (sold with NADC)	BAE	1.4 MB
iDEN measurement personality	HN1	1.7 MB
W-CDMA measurement personality	BAF	4.2 MB ^c
cdma2000 measurement personality	B78	3.8 MB ^c
1xEV-DO measurement personality	204	5.7 MB ^c
Shared measurement library	n/a	1.5 MB

- a. Available as of the print date of this guide.
- b. For instruments that already have Option BAH licensed, order E4406AU Option 252 to add EDGE (with GSM).
- c. Some personality options use a shared measurement library. You have to add the memory requirements of this library to the value needed for the option. If you are loading multiple personalities that use this library, you only need to add this memory requirement once.

Loading an Optional Measurement Personality

You must load the desired personality option into the instrument memory. Loading can be done from the firmware CD-ROM or the internet location. An automatic loading program comes with the files and runs from your PC.

NOTE

When you add a new option, or update an existing option, you will get the updated version of all your current options since they are reloaded simultaneously. This process may also require you to update the instrument core firmware so that it is compatible with the new option.

Required Information:	Key Path:
Instrument Memory: _____	System, File System (This key is grayed out.) The total amount of memory in your instrument will be the sum of the Used memory and the Free memory.

You may not be able to fit all of the available measurement personalities in instrument memory at the same time. You may need to delete an existing option file from memory and load the one you want. Use the automatic update program that is provided with the files.

You may want (or need) to add optional memory to load all the different measurement personalities that you want. The approximate memory

requirements for the options are listed above. These numbers are worst case examples. Some options share components and libraries, therefore the total memory usage of multiple options may not be exactly equal to the combined total.

You can install an update version of core firmware and your licensed options using a LAN connection and your PC. The **Exit Main Firmware** key halts the operation of the instrument firmware so you can install an updated version. Instructions for loading future firmware updates are available from the following internet location:
www.agilent.com/find/vsa/

Installing a License Key

To install a license key number for the selected personality option, use the following procedure.

NOTE You can also use this procedure to reinstall a license key number that has been deleted during an uninstall process, or lost due to a memory failure

1. Press **System, More, More, Install, Choose Option** to access the alpha editor. Use this alpha editor to enter letters (upper-case), and the front-panel numeric keys to enter numbers for the option designation. You will validate your option entry in the active function area of the display. Then, press the **Done** key.

NOTE Before you enter the license key for the EDGE Retrofit Option 252, you must already have entered the license key for the GSM Option BAH.

2. Press **License Key** to enter the letters and digits of your license key. You will validate your license key entry in the active function area of the display. Then, press the **Done** key.
3. Press the **Install Now** key. The message “New option keys become active after reboot.” will appear, along with the **Yes/No** menu: press the **Yes** key and cycle the instrument power off and then on to complete your installation process, or press the **No** key to cancel the installation process.

Viewing a License Key

Measurement personalities purchased with your instrument have been installed and activated at the factory before shipment. You will receive a **License Key** unique to every measurement personality purchased. The license key number is a hexadecimal number specific to your measurement personality, instrument serial number and host ID. It enables you to install, or reactivate that particular personality.

Use the following procedure to display the license key number unique to

your personality option that is already installed in your instrument:

1. Press **System, More, More, Install, Choose Option** to access the alpha editor. Use this alpha editor to enter letters (upper-case) and the front-panel numeric keys to enter numbers for your option designation that is already installed in the instrument.
2. Press the **Done** key on the alpha editor. The license key number unique to your personality option will now appear on the **License Key** softkey.

*You will want to keep a copy of your license key number in a secure location. Press **System, More, Show System** and print out a copy of the display that shows the license numbers. If you should lose your license key number, call your nearest Agilent Technologies service or sales office for assistance.*

Using the Uninstall Key

This key will make the option unavailable for use, but will not delete it from memory. The message “Application Not Licensed” will appear in the Status/Info bar at the bottom of the display. Record the 12-digit license key number for the option before you delete it. If you want to use that measurement personality later, you will need the license key number to reactivate the personality firmware.

NOTE

Using the **Uninstall** key does not remove the personality firmware from the instrument memory, and does not free memory to be available to install another option. If you need to free memory to install another option, refer to the instructions for loading firmware updates available at the URL: www.agilent.com/find/vsa/

1. Press **System, More(1 of 3), More(2 of 3), Uninstall, Choose Option** to access the alpha editor. Use this alpha editor to enter the letters (upper-case), and the front-panel numeric keys to enter the numbers (if required) for the installed option. You will validate your option entry in the active function area of the display. Then, press the **Done** key.
2. Pressing the **Uninstall Now** key will activate the **Yes/No** menu: press the **Yes** key to continue your uninstall process, or press the **No** key to cancel the uninstall process.
3. Cycle the instrument power off and then on to complete the uninstall process.

Setting Up the Mode
Installing Optional Measurement Personalities

3 Making Measurements

GSM and EDGE Measurements

The following measurements for the GSM 450, GSM 480, GSM 700, GSM 850, GSM 900, DCS 1800, and PCS 1900 bands are available by pressing the **Measure** key (except for the Tx Band Spurs and EDGE Tx Band Spurs measurements, which support P-GSM, E-GSM, R-GSM, DCS 1800, and PCS 1900 only):

- “Making the Transmit Power Measurement” on page 74
- “Making the GMSK Power vs. Time Measurement” on page 79
- “Making the GMSK Phase and Frequency Error Measurement” on page 88
- “Making the GMSK Output RF Spectrum Measurement” on page 95
- “Making the GMSK Tx Band Spur Measurement” on page 107
- “Making the EDGE Power vs. Time Measurement” on page 111
- “Making the EDGE EVM Measurement” on page 121
- “Making the EDGE Output RF Spectrum Measurement” on page 130
- “Making the EDGE Tx Band Spur Measurement” on page 142
- “Making the Spectrum (Frequency Domain) Measurement” on page 146
- “Making the Waveform (Time Domain) Measurement” on page 155

These are referred to as one-button measurements. When you press the key to select the measurement it will become the active measurement, using settings and a display unique to that measurement. Data acquisitions will automatically begin provided trigger requirements, if any, are met.

Preparing for Measurements

If you want to set the mode to a known, factory default state, press **Preset**. This will preset the mode setup and all of the measurements to the factory default parameters.

NOTE

Pressing the **Preset** key does not switch instrument modes.

To preset only the settings that are specific to the selected measurement, press **Meas Setup, More, Restore Meas Defaults**. This will set the measure setup parameters, for the currently selected measurement only, to the factory defaults.

Initial Setup

Before making a measurement, make sure the mode setup and frequency/channel parameters are set to the desired settings. Refer to the sections “[Changing the Mode Setup](#)” and “[Changing the Frequency Channel](#)” in the previous chapter.

How to Make a Measurement

Follow the three-step process shown in the table below:

Step	Primary Key	Setup Keys	Related Keys
1. Select & setup a mode	Mode	Mode Setup, Input, FREQUENCY Channel	System
2. Select & setup a measurement	Measure	Meas Setup	Meas Control, Restart
3. Select & setup view	View/Trace	SPAN X Scale, AMPLITUDE Y Scale, Display, Next Window, Zoom	File, Save, Print, Print Setup, Marker, Search

Measurement Control

The **Meas Control** front panel menu key controls processes that affect the running of the current measurement.

- **Measure** softkey. Press **Meas Control**, **Measure** (not to be confused with the front panel **Measure** key which has a different function) to toggle between **Single** and **Cont** (for continuous) measurement states. When set to **Single**, the measurement will continue until it has reached the specified number of averages set by the average counter. When set to **Continuous**, the measurement will run continuously, and perform averaging according to the current average type (repeat or exponential). The default setting is continuous.
- **Pause** key. Press **Meas Control**, **Pause** to pause the current measurement. Once toggled, the label of the **Pause** key changes to read **Resume**. The **Resume** key, once pressed, continues the active measurement from the point at which it was paused.
- **Restart** key. The **Restart** front panel key repeats the current measurement from the beginning, while retaining the current measurement settings.

Measurement Setup

The **Meas Setup** key accesses features that enable you to adjust parameters of the current measurement, such as resolution bandwidth. You will also use the **Meas Setup** menu to access the **Average**, **Trig Source**, and **Advanced** measure setup feature menus.

The following measure setup features can be used with many or all measurements.

- **Res BW** key. Press **Meas Setup**, **Res BW** to change the resolution of a given measurement. Selection of a narrower bandwidth will result in a longer data acquisition time.
- **Restore Meas Defaults** key. To preset only the settings that are specific to the selected measurement, press **Meas Setup**, **More**, **Restore Meas Defaults**. This will set the measure setup parameters, for the currently selected measurement only, to the factory defaults.

Averaging

Selecting one of the averaging keys in the **Meas Setup** menu will allow you to modify the number, mode, and type of averaging you use for the currently selected measurement.

- **Averages**, **Avg Bursts On Off** and **Avg Number** - Allow you to change the number of N averages that are made. **Avg Number** - Also allows you to select whether averages are made or not.
- **Avg Mode Exp Repeat** - Allows you to choose either exponential or repeat averaging. This selection only effects the averaging after the number of N averages is reached (set using the **Averages**, **Avg Bursts**, or **Avg Number** key).
 - **Normal averaging**: Normal (linear) averaging is always used until the specified number of N averages is reached. When **Measure** is set at **Single**, data acquisitions are stopped when the number of averages is reached - thus **Avg Mode** has no effect on single measurements.
 - **Exponential averaging**: When **Measure** is set at **Cont**, data acquisitions will continue indefinitely. After N averages, exponential averaging is used with a weighting factor of N (the displayed average count stops at N). Exponential averaging weights new data more than old data, which allows tracking of slow-changing signals. The weighting factor N is set using the **Averages**, **Avg Bursts**, or **Avg Number** key.
 - **Repeat averaging**: When **Measure** is set at **Cont**, data acquisitions will continue indefinitely. After N averages is reached, all previous result data is cleared and the average count is set back to 1. This is equivalent to being in **Measure Single** and pressing the **Restart** key when the Single measurement finishes.

- **Avg Type** - Select the averaging type from the following selections:
(Not all of the selections are available for all measurements)
 - Pwr Avg (RMS)** - True power averaging that is equivalent to taking the RMS value of the voltage. It is the most accurate type of averaging.
 - Log-Pwr Avg (Video)** - Simulates the traditional spectrum analyzer type of averaging by averaging the log of the power.
 - Mean** - Averages the mean values.
 - Voltage Avg** - Averages the voltage values.
 - Maximum** - Keeps track of the maximum values.
 - Minimum** - Keeps track of the minimum values.
 - Max & Min** - Keeps track of the maximum and minimum values.

Trig Source

Changing the selection in the **Trig Source** menu alters the trigger source for the selected measurement only. Not all of the selections are available for all measurements. Note that the **RF Burst (Wideband)**, **Video (IF Envlp)**, **Ext Front**, and **Ext Rear** menu keys found in the **Trigger** menu enable you to change settings to modify the delay, level, and slope for each of these trigger sources. Choose one of the following sources:

- **Free Run (Immediate)** - The trigger occurs at the time the data is requested, completely asynchronous to the RF or IF signal.
- **RF Burst (Wideband)** - An internal wideband RF burst trigger that has an automatic level control for burst signals. It triggers on a level that is relative to the peak of the signal passed by the RF. If the data sent is all 0 bits, this trigger will give erratic or falsely high EVM results.
- **Video (IF Envlp)** - An internal IF envelope trigger. It triggers on an absolute threshold level of the signal passed by the IF.
- **Ext Front** - Activates the front panel external trigger input (**EXT TRIGGER INPUT**). The external trigger must be a signal between -5 and $+5$ volts.
- **Ext Rear** - Activates the rear panel external trigger input (**TRIGGER IN**). The external trigger must be a signal between -5 and $+5$ volts.
- **Frame** - Uses the internal frame clock to generate a trigger signal. The clock parameters are controlled under the **Mode Setup** key or the measurement firmware, but not both. See the specific measurement for details.
- **Line** - activates an internal line trigger. Sweep triggers occur at intervals synchronized to the line frequency.

Rear panel **TRIGGER 1 OUT** and **TRIGGER 2 OUT** connectors are coupled to the selected trigger source. These trigger outputs are always on the rising edge with a pulse width of at least 1 μ s.

Burst Sync

Pressing the **Burst Sync** key allows you to choose the source used to synchronize the measurement to the “T0” point of the GSM or EDGE burst. The “T0” point is defined as the time point of the transition from bit 13 to bit 14 of the midamble training sequence for a given time slot. The

Burst Search Threshold setting (in the **Mode Setup** keys under **Trigger**) applies to both **Training Seq** and **RF Amptd**. It is described on [“Changing the Mode Setup” on page 36](#). Pressing the **Burst Sync** key will bring up a menu with some or all of the following choices:

- **Training Seq** - Synchronizes the measurement to the timing of the demodulated training sequence in the GSM burst. This is the most precise method, but requires a GMSK or EDGE burst with a valid TSC (Training Sequence Code). The “T0” point is determined by demodulation of the burst and successful identification of the TSC. “T0” is then found to within 1/10 bit.
- **RF Amptd** - Synchronizes the measurement to the burst transition of the measured RF carrier. “T0” is set to the 50% point between the start and end of the burst.
- **None** - Use the start of the time record as the start of the useful part. “T0” is set to the middle of the useful part.
- **Ext** - Use the external trigger plus delay as the start of the useful part. “T0” is set to the middle of the useful part.

Making the Transmit Power Measurement

Purpose

Transmit Power is the measure of in-channel power for GSM and EDGE systems. Mobile stations and base transceiver stations must transmit enough power, with sufficient modulation accuracy, to maintain a call of acceptable quality without leaking into frequency channels or timeslots allocated for others. GSM and EDGE systems use dynamic power control to ensure that each link is maintained with minimum power. This gives two fundamental benefits: overall system interference is kept to a minimum and, in the case of mobile stations, battery life is maximized.

The Transmit Power measurement determines the average power for an RF signal burst at or above a specified threshold value. The threshold value may be absolute, or relative to the peak value of the signal.

At the base transceiver station, the purpose of the Transmit Power measurement is to determine the power delivered to the antenna system on the radio-frequency channel under test. The Transmit Power measurement verifies the accuracy of the mean transmitted RF carrier power. This can be done across the frequency range and at each power step.

Measurement Method

The instrument acquires a GSM or EDGE signal in the time domain. The average power level above the threshold is then computed and displayed. This measurement uses the “power-above-threshold” method instead of the “useful part of the burst” method defined in the GSM standards. The measured Transmit Carrier Power will be very nearly the same for these two methods. The power-above-threshold method has the advantages of being faster and allows power measurements to be made at somewhat lower power levels. It also has the advantage of not requiring the carrier to have a valid TSC (Training Sequence Code).

Note that this measurement does not provide a way to specify which timeslot is to be measured. Therefore if multiple timeslots are on, they should all be set at the same power level, or the levels of those timeslots to be excluded need to be kept below the threshold level. If you want to measure Transmit Carrier Power using the GSM specified useful part of the burst method, use the Power vs. Time or EDGE Power vs. Time measurements, which also measure the power ramping of the burst.

Making the Measurement

NOTE

For special requirements, you may need to change some of the settings. Press **Meas Setup, More (1 of 2), Restore Meas Defaults** at any time to return all parameters for the current measurement to their default settings.

Select the desired ARFCN, center frequency, and burst type as described in the section titled [“Changing the Frequency Channel”](#) on [page 41](#).

Press **Measure, Transmit Pwr** to immediately make Transmit Power the active measurement.

To change any of the measurement parameters from the factory default values, refer to the [“Changing the Measurement Setup”](#) section for this measurement.

Results

Figure 3-1 Transmit Power Result - Single Burst (with data table)

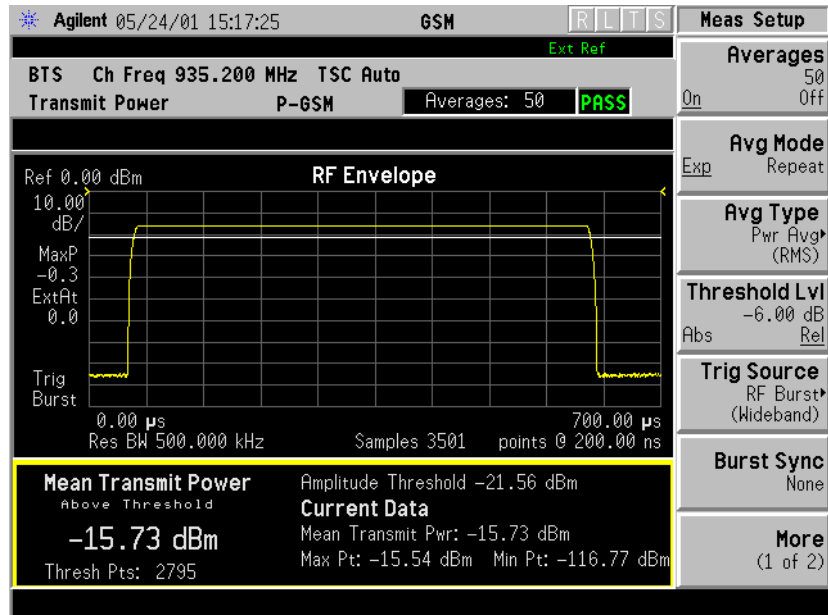
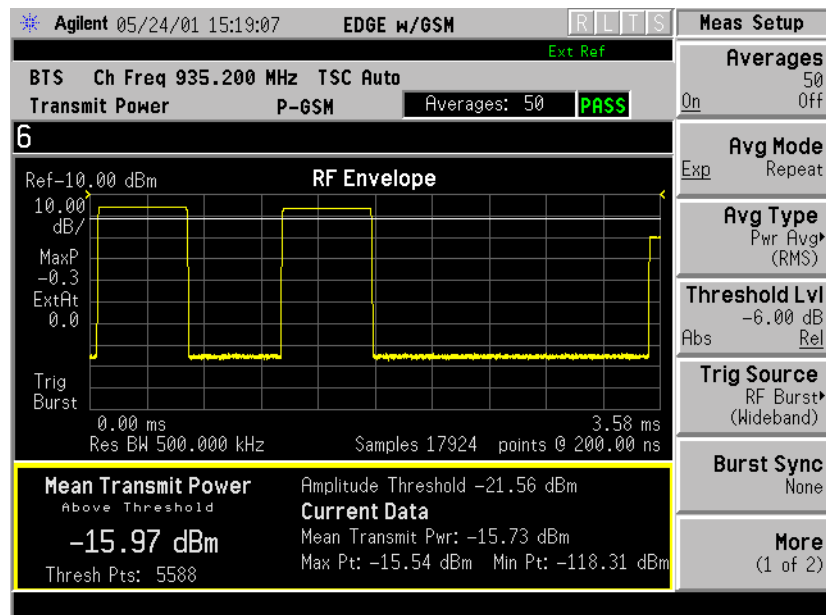

Figure 3-2 Transmit Power Result - Multiple Bursts



Changing the Measurement Setup

Table 3-1 Transmit Power Measurement Defaults

Measurement Parameter	Factory Default Condition
Averages	50 On
Avg Mode	Exp
Avg Type	Pwr Avg (RMS)
Threshold Lvl	-6.00 dB Rel (to peak)
Trig Source	RF Burst (Wideband)
Burst Sync	None
Meas Time	1 slot
Advanced	
RBW Filter	Gaussian
Res BW	500.000 kHz

NOTE

Parameters that are under the **Advanced** key seldom need to be changed. Any changes from the factory default values may result in invalid measurement data.

Make sure the Transmit Power measurement is selected under the **Measure** menu. Press the **Meas Setup** key to access a menu which allows you to modify the averaging, trigger source, and burst sync for this measurement (as described in the “[Measurement Setup](#)” section at the beginning of this chapter). In addition, the following transmit power measurement parameters can be modified:

- **Threshold Lvl Abs Rel** - choose absolute or relative and enter a value for the threshold level. The absolute value sets the threshold line at that power level. The relative value will set the threshold line at a specified level relative to the peak of the burst. The measurement will determine the average power of all data above this threshold.
- **Burst Sync** - an information only key. The selection cannot be changed for this measurement.
- **Meas Time** - allows you to measure more than one timeslot. Enter an integer value in increments of “slots” with a range of 1 to 50. The actual measure time is set somewhat longer than the specified number of slots in order to view the complete burst.

- **Advanced** - accesses a menu to change the following parameters:

RBW Filter - this key toggles to select a Flat Top or a Gaussian (the default filter) resolution bandwidth filter. A Gaussian filter minimizes distortion products in the time domain, particularly for bursts. A Flat Top filter provides a flatter bandwidth but is less accurate for pulse responses. A Flat Top filter also requires less memory and allows longer data acquisition times.

Res BW - sets the resolution bandwidth.

TIP

When measuring transmit power on a GMSK signal, you can get about 3 dB more dynamic range by manually decreasing the input attenuation. The measurement is set to handle both GMSK and EDGE signals. In order to accommodate the greater peak-to-average power ratio of EDGE signals it automatically chooses a higher attenuation than required for a GMSK signal.

Troubleshooting Hints

Low output power can lead to poor coverage and intermittent service for phone users. Out of specification power measurements indicate a fault usually in the power amplifier circuitry. They can also provide early indication of a fault with the power supply, i.e. the battery in the case of mobile stations.

Making the GMSK Power vs. Time Measurement

Purpose

NOTE This measurement is designed for GSM. For EDGE measurements see [“Making the EDGE Power vs. Time Measurement” on page 111](#)

Power vs. Time measures the mean transmit power during the “useful part” of GSM bursts and verifies that the power ramp fits within the defined mask. Power vs. Time also lets you view the rise, fall, and “useful part” of the GSM burst. Using the “Multi-Slot” function, up to eight slots in a frame can be viewed at one time.

GSM is a Time Division Multiple Access (TDMA) scheme with eight time slots, or bursts, per RF channel. If the burst does not occur at exactly the right time, or if the burst is irregular, then other adjacent timeslots can experience interference. Because of this, the industry standards specify a tight mask for the fit of the TDMA burst.

The Power vs. Time measurement provides masks for both BTS (Base Transceiver Station) and MS (mobile station). The timing masks are referenced to the transition from bit 13 to bit 14 of the midamble training sequence. For GMSK measurements, the 0 dB reference is determined by measuring the mean transmitted power during the “useful part” of the burst. You can also define a user configurable limit mask to apply to the measured burst using SCPI commands (refer to the [“Changing the Measurement Setup” on page 77](#)).

The GSM specifications defines the “useful part” of the normal GSM burst as being the 147 bits centered on the transition from bit 13 to bit 14 (the “T0” time point) of the 26 bit training sequence.

Measurement Method

The instrument acquires a GSM signal in the time domain. The “T0” point and the useful part are computed. If Burst Sync is set to **Training Seq**, a GSM demodulation is performed to find “T0”. If Burst Sync is set to **RF Amptd**, an approximation of “T0” will be used without performing a demodulation. The average power in the useful part is then computed and displayed, and the GSM limit mask is applied. A **PASS** annunciator appears in the instrument display when the burst fits within the bounds of the mask.

Making the Measurement

NOTE

The factory default settings provide a GSM standard compliant measurement. For special requirements, you may need to change settings. Press **Meas Setup, More (1 of 2), Restore Meas Defaults** at any time to return all parameters for the current measurement to their default settings.

Press **Measure, Pwr vs Time** to activate the power vs. time measurement.

Press **Frequency** to select an ARFCN channel or to enter a numeric value for the center frequency.

There are five keys that are frequently used to change power vs. time measurement settings. These are the **Timeslot, Burst Type, and TSC(Std)** keys located in the **Frequency** menu, and the **Trig Source** and **Burst Sync** keys located in the **Meas Setup** menu.

First, press **Trig Source**. The trigger source determines how the analyzer acquires a frame of data. If **Ext Front** or **Ext Rear** is selected an external, known reference in time will be provided for the data acquisition. If **RF Burst** is selected the rising edge of a burst will be used to initiate data acquisition.

Once data is acquired, the time record is interpreted as a sequence of eight slots. When an **Ext Front** or **Ext Rear** trigger source is selected, the trigger is assumed to be positioned near the beginning of the base station's timeslot. However, if the external trigger is more than 25% away from the burst, the analyzer will not identify the burst and will fail to place a mask on it. If the external trigger is too far away from the burst, you can compensate for this by entering a value for the external trigger delay to bring the burst back into the alignment range of the mask. When the external trigger is not coincident in time with the beginning of the base station's timeslot, press **Mode Setup**, then use the **Trigger** key to select the trigger; once the trigger is selected the **Delay** key will allow you to enter a value for trigger delay.

When **Trig Source** is set to **RF Burst**, data acquisition is delayed until the rising edge of an active timeslot burst. The issue of timeslot tolerance will then apply to any subsequent active time bursts within the frame. Thus, the analyzer uses the rising edge of the RF burst to define the beginning of the first timeslot of the data record.

The analyzer does not perform the protocol analysis that is necessary to identify which absolute slot number a frame is triggering on. If it is necessary to position the measurement on an absolute slot within the GSM frame, an external trigger must be used. As an alternative, a burst of interest can be identified by placing a unique training sequence in it, and setting **TSC(Std)** to manual; this requires that you are able to configure the burst to contain a specified training sequence.

When **Burst Sync** is set to **Training Seq** the analyzer demodulates the burst to identify the training sequence and bit timing, so it can accurately position the limit mask according to the standard. In this case, the **Burst Type** setting (the choices are **Normal**, **Sync**, and **Access**) tells the analyzer demodulation algorithm which burst bit structure should be used.

If **Burst Sync** is set to **RF Amptd**, demodulation is not used and the analyzer then positions the mask in relation to the rising edge of the RF burst.

The timeslot feature is an offset feature that is used to select the “burst of interest”. The “burst of interest” represents the portion of the acquired data record that receives analysis for interpretation as a valid burst; this is the burst to which a limit mask is applied and for which power calculations are generated. When the multi-slot view is selected, all slots in the view are tested for application of the limit mask, but the burst of interest is the one that will be indicated in blue text in the multi-slot table.

For example, if **Timeslot** is set to **On** and 3 is selected, the burst of interest will be offset by 3 slots from the beginning of the acquired time record, and the limit mask will be applied to this burst. If the selected timeslot attempts to locate a burst of interest where no burst is active, the mask application will fail. Timeslot functions as a time pointer offset in the acquired data record, regardless of the **Trig Source** setting.

Once determined, the burst of interest will be demodulated if **Burst Sync** is set to **Training Seq**. **TSC(Std)** applies only when **Burst Sync** is set to **Training Seq**.

When **TSC(Std)** is set to manual, demodulation will search for that specific training sequence number. If it is not found, a limit mask will not be applied, and an error will be reported. When **TSC(Std)** is set to **Auto**, demodulation will search the burst of interest for any of the eight standard training sequences, and use it for to find the true center of the burst so the mask can be applied accurately.

Making Multi-Slot Measurements

First set **Meas Time** to the number of slots you want to view, then activate the **Multi-Slot** view, which is found in the **View/Trace** menu.

You can use the following method to ensure that timeslots 0 - 7 in the transmitted frame correlate with timeslots 0 - 7 as viewed in the transmitter tester:

- Use an external trigger. The Agilent ESG signal generator series, for example, has an “event 1” rear panel output which triggers at the beginning of the frame. Connect the trigger from the signal generator to an external trigger input connector on the transmitter tester, then select the appropriate connector using the **Trigger Source**

key in the **Meas Setup** menu.

Selecting the Burst of Interest

The burst of interest is indicated in blue text in the table shown below the multi slot view. Press the **Burst** view key to view the burst of interest.

- If a timeslot contains a burst with a standard training sequence that is unique to the frame, the specified training sequence can be used to select the timeslot in which the burst of interest occurs. Set **Trigger** to **RF Burst**, set **Burst Sync** to **Training Seq**, and in the **Freq/Chan** menu set **Timeslot** to **OFF**. Then set **TSC (Std)** to **Man** (manual) and enter the training sequence number.
- If only one timeslot in a given frame contains a burst with a standard training sequence, then the specified training sequence can be used to select the timeslot in which the burst of interest occurs. Set **Trigger** to **RF Burst**, **Burst Sync** to **Training Seq**, and in the **Freq/Chan** menu set **Timeslot** **OFF**. Then set **TSC (Std)** to **Auto** and the trigger will automatically search through the available standards for a matching training sequence number.

Results

The views available under the **View/Trace** menu are **Burst**, **Rise & Fall**, and **Multi-Slot**. See [“Changing the View” on page 86](#).

Information shown in the left margin of the displays include:

- **MaxP** - This is total input power allowed for the measurement. This value is coupled to the internal **RF Input Atten** setting.
- **ExtAt** - This value reflects the **External RF Atten** setting.
- **Sync** - The **Burst Sync** setting used in the current measurement
- **Trig** - The **Trigger Source** setting used in the current measurement

The Current Data displayed at the bottom of the **Burst** and **Rise & Fall** views include:

- **Max Pt.** - Maximum signal power point in dBm
- **Min Pt.** - Minimum signal power point in dBm
- **Burst Width** - Time duration of burst at -3 dB power point (half-power)
- **Mask Ref Pwr Midamble** - The Mask Reference Power is the average power in dBm of the middle 16 symbols in the midamble. The times displayed are the corresponding start and stop times of the middle 16 symbols.
- **1st Error Pt** - (Error Point) The time (displayed in ms or μ s)

indicates the point on the X Scale where the first failure of a signal was detected. Use a marker to locate this point in order to examine the nature of the failure.

The table in the lower portion of the multi-slot view shows the output power in dBm for each timeslot, as determined by the integer (1 to 8) entered in the **Meas Setup, Meas Time** setting. Output power levels are presented for the active slots; a dashed line will appear for any slot that is inactive. The timeslot that contains the burst of interest is highlighted in blue.

Figure 3-3 GMSK Power vs. Time Result - Burst View

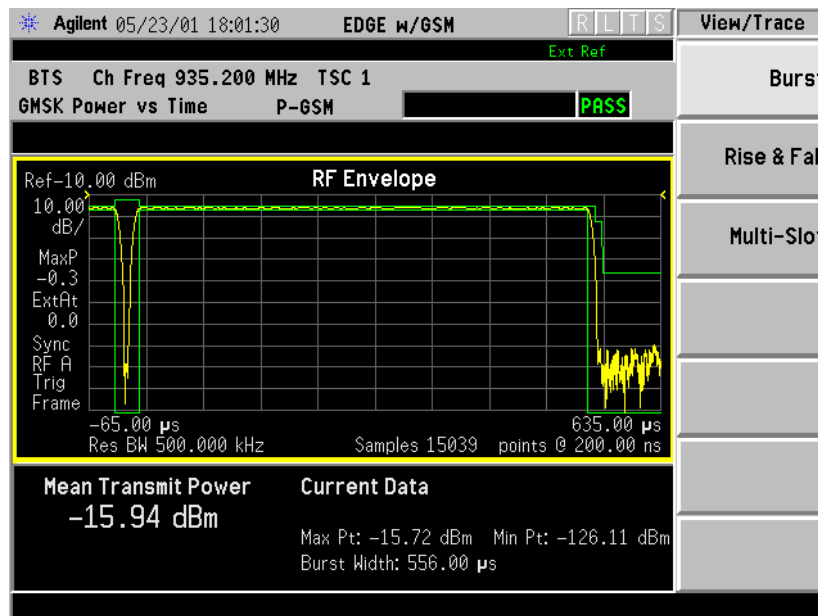

Figure 3-4 GMSK Power vs. Time Result - Rise & Fall View

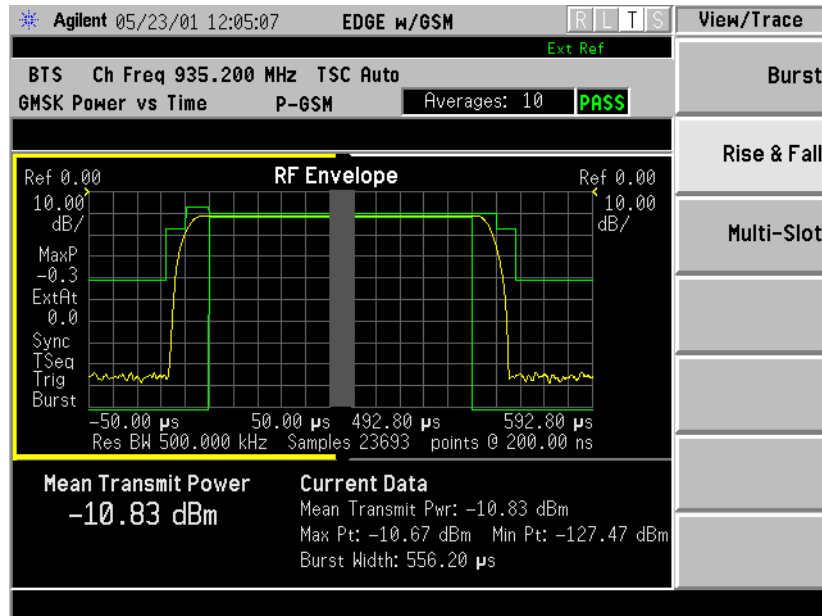
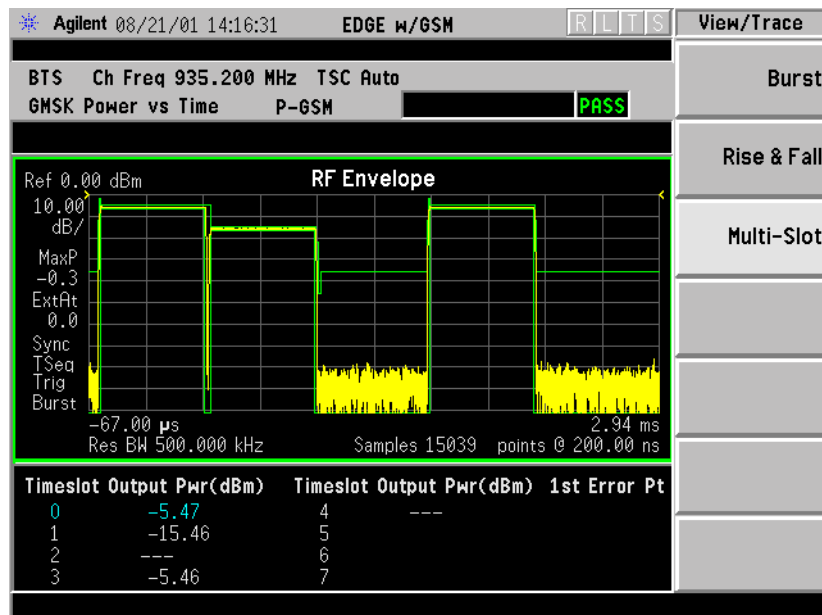

Figure 3-5 GMSK Power vs. Time Result - Multi-Slot View (5 slots shown)



Changing the Measurement Setup

Table 3-2 Power vs. Time Measurement Defaults

Measurement Parameter	Factory Default Condition
Avg Bursts	10 Off
Avg Mode	Exp
Avg Type	Pwr Avg (RMS)
Meas Time	1 Slot
Timeslot	0 Off
Trig Source	RF Burst (Wideband)
Burst Sync	Training Seq
Advanced	
RBW Filter	Gaussian
Res BW	500.000 kHz

NOTE

Parameters that are under the **Advanced** key seldom need to be changed. Any changes from the default values may result in invalid measurement data.

Make sure the Power vs. Time measurement is selected under the **Measure** menu. The **Meas Setup** key will access a menu which allows you to modify the averaging, trigger source, and burst sync for this measurement (as described in the [“Measurement Setup” on page 71](#)). In addition, the following power vs. time measurement parameters can be modified:

- **Pwr Cntrl Lvl** - used to indicate the output power of the transmitter; in MS testing transmitter output power variations will affect the mask (in BTS testing the mask is unaffected). The appropriate power level for measuring the device under test will correspond with the transmitter power control level setting.
- **Meas Time** - allows you to measure more than one timeslot. Enter a value in integer increments of “slots” with a range of 1 to 8. The actual measure time in μs is set somewhat longer than the specified number of slots in order to view the complete burst.
- **Advanced** - accesses a menu to change the following parameters:
 - RBW Filter** - chooses the type of filter, either **Gaussian** or **Flat** (Flatop). Gaussian is the best choice when looking at the overall burst or the rising and falling edges, as it has excellent pulse response. If you want to precisely examine just the useful part of the burst, choose **Flat**.

Res BW - sets the resolution bandwidth.

Power vs. Time Custom Masks

For the Power vs. Time measurement, you can define a user configurable limit mask to apply to the measured burst. This feature can only be accessed via SCPI commands. Refer to the [Chapter 4](#), “Programming Commands,” on page 163. Refer to Chapter 4, GSM Programming Commands.

Changing the View

The **View/Trace** key accesses a menu that allows you to select the desired view of the measurement from the following selections:

- **Burst** - views the entire burst of interest as determined by the current trigger source, burst sync, training sequence, and timeslot settings. To view a different burst of interest you must set these parameters for the selected timeslot. To view multiple slots use the **Multi-Slot** key described below. See [Figure 3-3 on page 83](#)
- **Rise & Fall** - zooms in on the rising and falling portions of the burst being tested. See [Figure 3-4 on page 84](#).

NOTE

The limit test will still be performed on the entire burst (viewed using the **Burst** menu) when **Rise & Fall** is selected.

- **Multi-Slot** - views the entire sweep as specified by the current **Meas Time** setting. Power levels for each active slot are listed in a table below the timeslot display. Also shown in the table under **1st Error Pt.** is the point in time at which the signal level first exceeds the limit; this will help identify the slot where a failure first occurs. See [Figure 3-5 on page 84](#).

Use the **Meas Time** key located in the **Meas Setup** menu to select up to eight slots. Use the **Timeslot** and **TSC** keys in the **Frequency/Channel** menu to select the slot you wish to activate. Setting **Timeslot** to **ON** and selecting a specific slot results in activating a measurement of that slot only (**Timeslot On** can be used to isolate a failure to a specific slot). When **Timeslot** is set to **OFF**, all active slots are tested against the mask.

Using a signal generator you can synchronize the multi-slot view so the frame (or portion of the frame) you are viewing starts with the slot you have selected. See [“Making Multi-Slot Measurements” on page 81](#).

You can switch from the multi-slot view directly to the burst or rise and fall views of the slot that is currently active. The **Scale/Div** key under the **Span/Y Scale** menu can be used to enlarge your view of this signal.

Changing the Display

The **Display** key will allow you to turn the limit mask on and off. This also disables the mask limit test, but still calculates the power in the useful part.

Troubleshooting Hints

If a transmitter fails the Power vs. Time measurement this usually indicates a problem with the units output amplifier or leveling loop.

Making the GMSK Phase and Frequency Error Measurement

NOTE This measurement is designed for GSM only.

Purpose

Phase and frequency error are the measures of modulation quality for GSM systems. Since GSM systems use relative phase to transmit information, the phase and frequency accuracy of the transmitter are critical to the systems' performance and ultimately affect range.

GSM receivers rely on the phase and frequency quality of the 0.3 GMSK signal in order to achieve the expected carrier to noise performance. A transmitter with high phase and frequency error will often still be able to support phone calls during a functional test. However, it will tend to provide difficulty for mobiles trying to maintain service at the edges of the cell, with low signal levels or under difficult fading and Doppler conditions.

Measurement Method

The phase error of the test signal is measured by computing the difference between the phase of the transmitted signal and the phase of a theoretically perfect signal.

The instrument samples the transmitter output in order to capture the actual phase trajectory. This is then demodulated and the ideal phase trajectory is mathematically derived. Subtracting one from the other results in an error signal.

This measurement allows you to display these errors numerically and graphically on the analyzer display. It also allows you to view a binary representation of the demodulated data bits.

Making the Measurement

NOTE

The factory default settings provide a GSM compliant measurement. For special requirements, you may need to change some of the settings. Press **Meas Setup, More (1 of 2), Restore Meas Defaults** at any time to return all parameters for the current measurement to their default settings.

Select the desired ARFCN, center frequency, timeslot, burst type, and TSC (Training Sequence Code) as described in the section titled [“Changing the Frequency Channel” on page 41](#).

Select the type of carrier to measure. Press **Mode Setup, Radio, Carrier** and select **Burst** to measure a burst carrier, or **Cont** to measure a continuous carrier from a non-bursting base station.

When **Training Sequence** is selected as the burst sync for this measurement, set the **Timeslot** selection to determine which timeslot to measure. For example, if **Timeslot** is set to 2, the measurement will be made on the timeslot number 2. Be careful when adding delay in the **Trigger setup**, as this measurement does not take into account trigger delay when checking for a valid burst. If there is sufficient delay added (usually more than 25% of a timeslot), the burst might not be detected.

Press **Measure, Phase & Freq** to immediately make Phase and Frequency Error the active measurement.

To change any of the measurement parameters from the factory default values, refer to the [“Changing the Measurement Setup”](#) section for this measurement.

Results

Figure 3-4

Figure 3-7 GMSK Phase and Frequency Error Result - Quad View

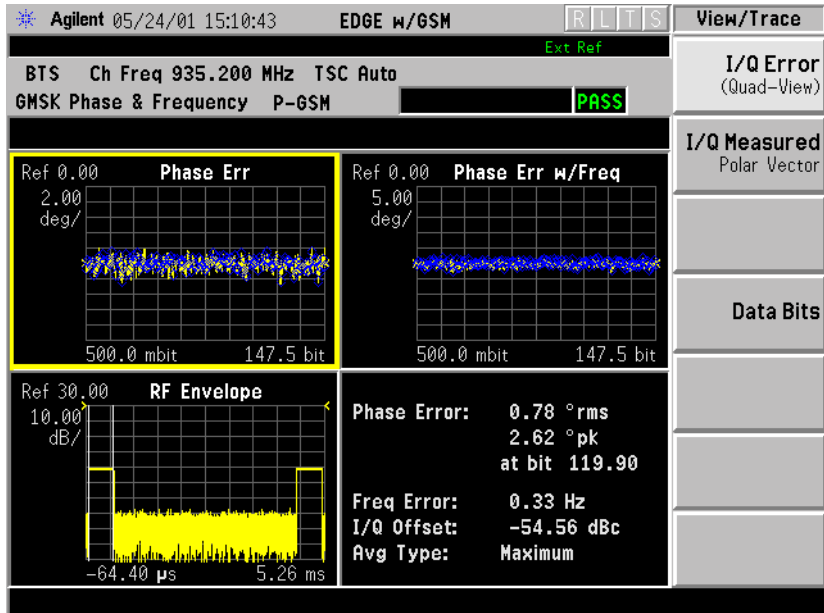

Figure 3-8 GMSK Phase and Frequency Error Result - Phase Error View

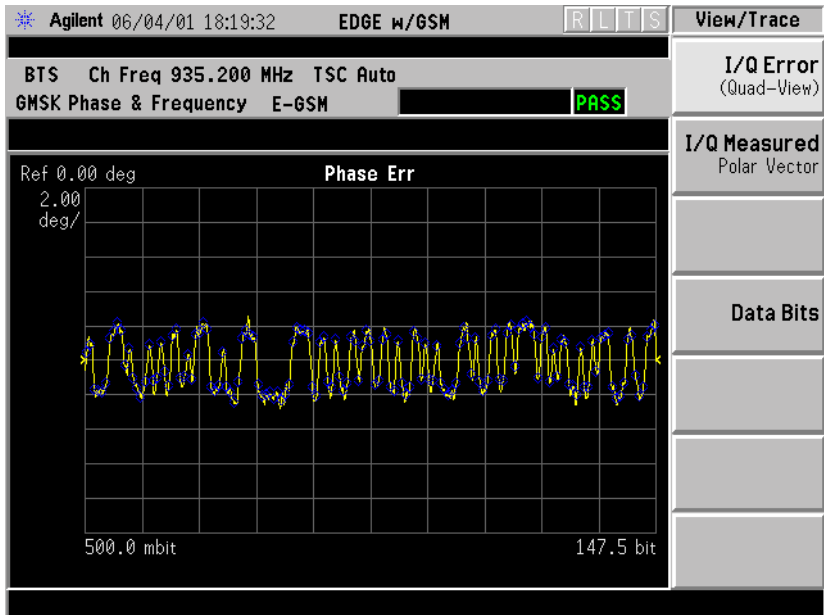

Figure 3-9 GMSK Phase and Frequency Error Result - RF Envelope View

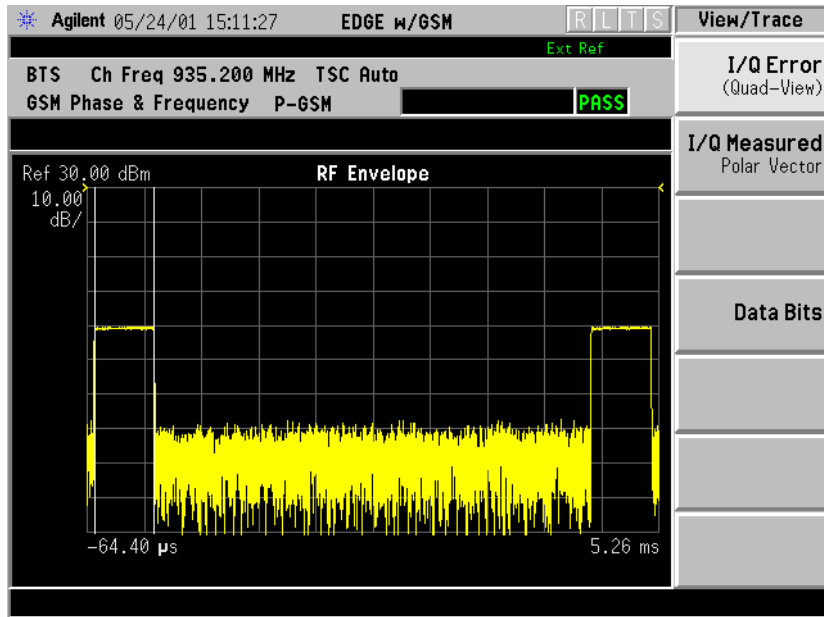

Figure 3-10 GMSK Phase and Frequency Error Result - Polar View

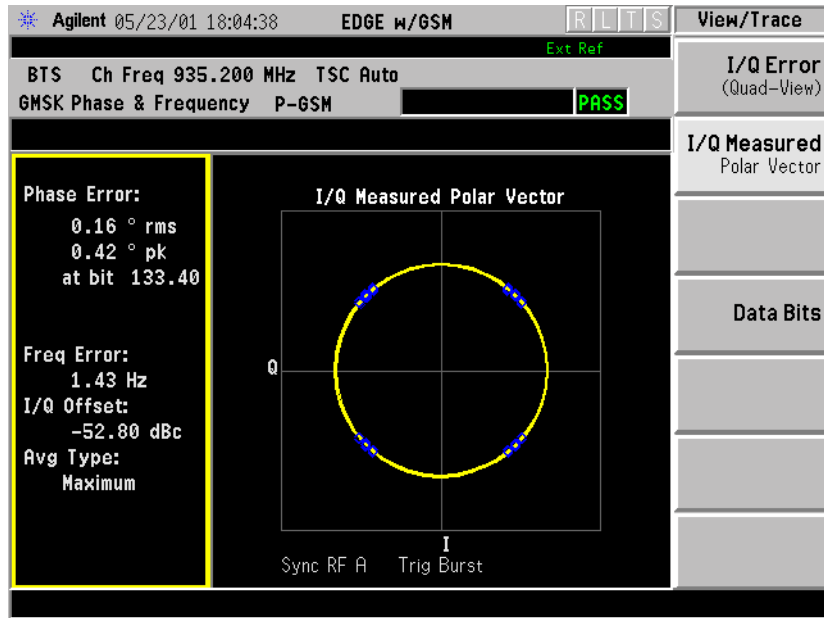
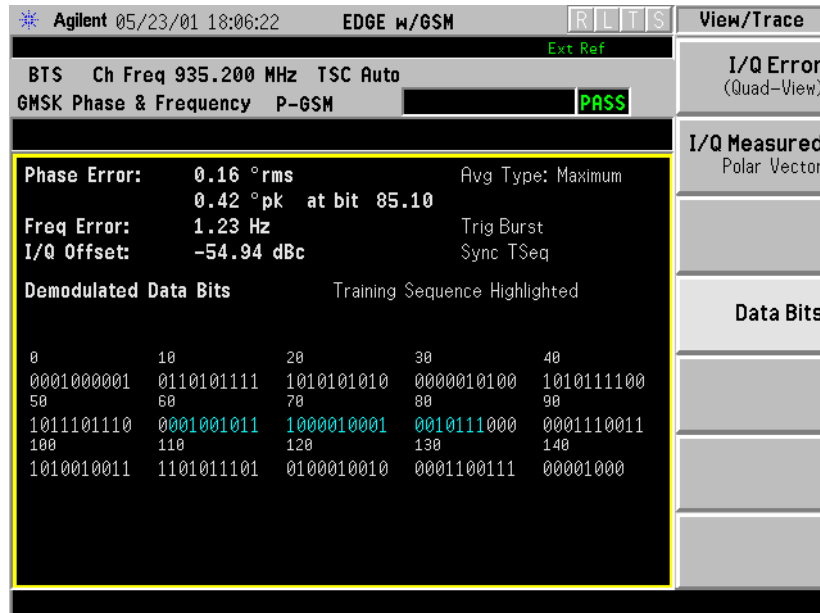

Figure 3-11 GMSK Phase and Frequency Error Result - Data Bits



Changing the Measurement Setup

Table 3-3 Phase and Frequency Error Measurement Defaults

Measurement Parameter	Factory Default Condition
Avg Bursts	10 Off
Avg Mode	Repeat
Avg Type	Maximum
Trig Source	RF Burst (Wideband)
Burst Sync	Training Sequence

NOTE Parameters that are under the **Advanced** key seldom need to be changed. Any changes from the default values may result in invalid measurement data.

Make sure the Phase and Frequency Error measurement is selected under the **Measure** menu. Press the **Meas Setup** key to access a menu which allows you to modify the averaging, trigger source, and burst sync for this measurement (as described in the “[Measurement Setup](#)” section at the beginning of this chapter).

Changing the View

The **View/Trace** key will allow you to select the desired view of the measurement from the following:

- **I/Q Error (Quad-View)** - Provides a combination view including

Window 1: Phase Error

Window 2: Phase Error with Freq

Window 3: RF Envelope

Window 4: Numeric Results and demodulated bits

Any of these windows can be selected (using the **Next Window** key) and made full size (using the **Zoom** key).

- **I/Q Measured Polar Vector** - Provides a view of numeric results and a polar vector graph.

Window 1: Numeric Results

Window 2: Polar Vector Graph

- **Data Bits** - Provides a view of the numeric results and data bits with the sync word (TSC) highlighted.

The menus under the **Span X Scale** and **Amplitude Y Scale** keys are context dependent upon the selected window (graph type). The **Span X Scale** parameters will be in units of time or bits, dependent on the view selected. The **Amplitude Y Scale** parameters will be in units of dB or degrees, dependent on the view selected. All of the softkey labels are blank when **I/Q Measured Polar Vector**, or **Data Bits** are selected.

Changing the Display

The **Display** key will allow you to turn the bit dots on and off.

Troubleshooting Hints

Poor phase error indicates a problem with the I/Q baseband generator, filters, or modulator in the transmitter circuitry. The output amplifier in the transmitter can also create distortion that causes unacceptably high phase error. In a real system poor phase error will reduce the ability of a receiver to correctly demodulate, especially in marginal signal conditions. This ultimately affects range.

Occasionally, a Phase and Frequency Error measurement may fail the prescribed limits at only one point in the burst, for example at the beginning. This could indicate a problem with the transmitter power ramp or some undesirable interaction between the modulator and power amplifier.

Making the GMSK Output RF Spectrum Measurement

Purpose

NOTE This measurement is designed for GSM. For EDGE Output RF Spectrum measurements see [“Making the EDGE Output RF Spectrum Measurement” on page 130](#).

The Output RF Spectrum measurement is the GSM version of the adjacent channel power (ACP) measurement. Either a single offset is measured with corresponding traces or up to 15 offsets are measured and a table is displayed. In spectrum due to modulation measurements a sweep spectrum display of -1.8 MHz to +1.8 MHz from the carrier can be viewed.

The output RF spectrum measurements determine the spectral energy emitted into the adjacent channels. Excessive amounts of energy spilling into an adjacent frequency channel could interfere with signals being transmitted to other MS or BTS. The measurements are divided into two main groups: spectrum due to the 0.3 GMSK modulation and noise, and spectrum due to switching transients (burst ramping).

Since GSM is a TDMA format, RF power is being switched on and off depending on whether the actual burst is being transmitted. The switching of power causes spectral splatter at frequencies other than that being transmitted by the carrier. Fast transitions in the time domain causes switching transients that have high frequency content associated with them.

NOTE The default output RF spectrum measurements do not perform tests at frequency offsets greater than 1800 kHz from the carrier.

Measurement Method

In this measurement, the transmitter (source) is set to transmit a GSM frame at a given channel (frequency). The instrument acquires a time record at a particular offset from the channel being transmitted. The method of acquiring the time record is either a FFT/Inverse-FFT method, or a direct time domain (DTD) method, depending on the offset. These two methods and when they are used, will be described below. When the offset is zero, the instrument is said to be measuring the carrier. For a given offset frequency from the carrier, the transmitter must not exceed a certain power level relative to the carrier. The GSM specification defines the offsets and their maximum absolute and relative power levels.

The general steps in making the measurement are as follows:

- Acquire time record (using either FFT or DTD methods, described below)
- Synchronize for gating on the carrier - finds 50% and 90% portion of burst for Spectrum Due to Modulation portion of the test
- Measure power of the carrier
- Compare each offset power to reference to get relative power level

The method of acquiring the time record is dependent on accuracy and dynamic range. With no pre-ADC filter (infinite bandwidth), the entire IF bandwidth of the IF signal is hitting the analog to digital converter (ADC). The ADC gain is set based on the peak level at its input. The dynamic range (noise floor) of the ADC is dependent on the gain selected. For the type of signals being measured, the highest energy within the IF bandwidth is at the carrier. Therefore, the lowest dynamic range (highest noise floor) of the ADC occurs when the full energy of the carrier is input to the ADC.

All offsets measured using the FFT method are done with the instrument tuned such that the carrier is at the center of the IF bandwidth. Therefore, the dynamic range of the offsets measured using the FFT method is the same as that for the carrier. The dynamic range requirement generally increases as the offset frequency increases. If the dynamic range requirement exceeds what is available by FFT method, the direct time domain (DTD) method utilizing the pre-ADC filter is used.

The **Direct Time Break Freq** key setting is the first offset frequency which is measured using the DTD method. Its range is determined by assuring no aliasing occurs on FFT offsets and that the dynamic range requirements are met.

The FFT method acquires a wideband signal (1.55 MHz) in a flattop filter. An FFT is performed to get the spectrum of the GSM signal. The resolution bandwidth filter can now be applied mathematically to the spectrum at multiple offsets, with an inverse-FFT performed on the data which passes the filter. In this way, multiple offsets are acquired from one time record and LO setting. Since the resolution bandwidth filter is a mathematical formula, it can be any shape and size, and is perfect. The measurement uses the 5-pole synchronously tuned filter that the GSM standard specifies.

The primary disadvantage to the FFT method is that the acquisition must include the carrier. The high energy of the carrier causes the ADC to range down, thus lowering the dynamic range. At large offsets, the dynamic range requirement is very challenging so the direct time domain (DTD) method is used. The LO is tuned to the particular offset and the pre-ADC filter is used to reduce the carrier. This allows the

ADC to range up, giving higher dynamic range. The disadvantage to this method is that each offset measured has its own time record acquisition and LO tune position, and this causes the measurement to slow down compared to FFT offsets. The 5-pole synchronously tuned filter is approximated by utilizing a digital Gaussian filter and setting its equivalent noise bandwidth to that of the 5-pole synchronously tuned filter. For these DTD offset frequencies, the filter has closer-to-ideal 5-pole behavior (< 1% tolerance) than does a 10% tolerance, 5-pole analog filter.

Regardless of how the time record is obtained for a particular offset, the power must be measured and compared to the reference power. There are two measurements being made for the test: output RF spectrum due to modulation and the output RF spectrum due to switching transients. The GSM standard specifies which offsets get which tests. In these two modes, the following conditions are met:

- In the output RF spectrum due to modulation measurement, the average value during at least 40 bits between bit 87 and 132 (approximately equivalent to the 50% to 90% portion of the burst, excluding midamble) is retained. The vertical lines mark the section of the burst over which the measurement is made. If multiple bursts are examined, an average of the average values is calculated. The relative power (difference between the average power of the burst at zero offset and the average power of the burst at the indicated offset) and the absolute power are displayed.
- In the output RF spectrum due to switching transients, the peak value of the whole frame is retained. The reference power of reference due to switching is the average power of the useful part of the burst with at least 300 kHz RBW. The relative power (difference between the mean transmit power of the burst at zero offset and the peak power of the burst at the indicated offset) and the absolute power are displayed.

The GSM standard specifies the tests are run on specified offsets from the carrier. The instrument identifies this as single offset or multiple offset modes. The measurement made in these two modes is the same, except that the multiple offset mode automatically makes the measurement at all the specified offsets frequencies and lists the results in a table at the end of the measurement.

In the output RF spectrum due to modulation measurement, setting the modulation method to discrete obtains results from specified offsets from the carrier as defined in the standard; the results are displayed in a table. When set to sweep, the measurement obtains results of a span extending to 1800 kHz from both sides of the carrier, measured in 10 kHz steps; the results are displayed as a spectrum.

The GMSK Phase and Frequency Results view shows a single-offset (Examine) trace for an entire GSM frame with timeslots 0, 2, and 6 turned on and timeslots 1, 3, 4, 5, and 7 turned off. The vertical bars

show the portion used to measure power due to modulation.

The RF envelope trace is displayed. If averaging is turned on, the trace is then averaged with previous traces. For the modulation measurement, the user may select the type of trace averaging, either log-power averaged (Video) or power averaged (RMS). For the switching transients measurement, the peak of the traces is used. For modulation, the displayed value is the average of points within the vertical bars. For transients, the displayed value is the max of all points for all traces (Max of Peak) over the entire frame.

Making the Measurement

NOTE

The factory default settings provide a GSM compliant measurement. For special requirements, you may need to change some of the settings. Press **Meas Setup, More (1 of 2), Restore Meas Defaults** at any time to return all parameters for the current measurement to their default settings.

Select the desired ARFCN, center frequency, timeslot, burst type, and TSC (Training Sequence Code) as described in the section titled [“Changing the Frequency Channel” on page 41](#).

When **Training Sequence** is selected as the burst sync for this measurement, set the **Timeslot** selection to determine which timeslot to measure. For example, if **Timeslot** is set to 2, the measurement will be made on the timeslot number 2. Be careful when adding delay in the **Trigger** setup, as this measurement does not take into account trigger delay when checking for a valid burst. If there is sufficient delay added (usually more than 25% of a timeslot), the burst might not be detected.

Press **Measure, Output RF Spectrum** to immediately make Output RF Spectrum the active measurement.

To change any of the measurement parameters from the factory default values, refer to the [“Changing the Measurement Setup” on page 101](#) section for this measurement.

Results

Figure 3-12 GMSK ORFS Result - Modulation Sweep Spectrum

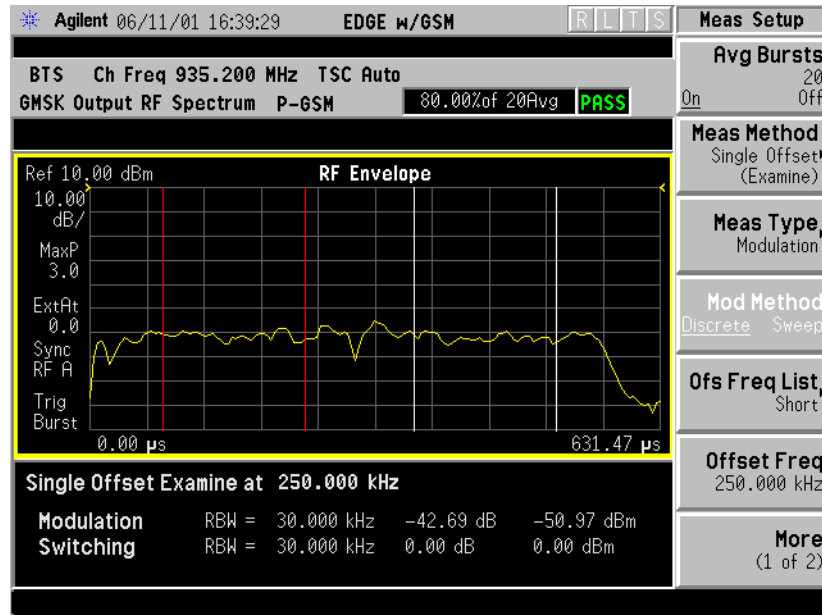

Figure 3-13 GMSK ORFS Result - Frame in Single-Offset (Examine)

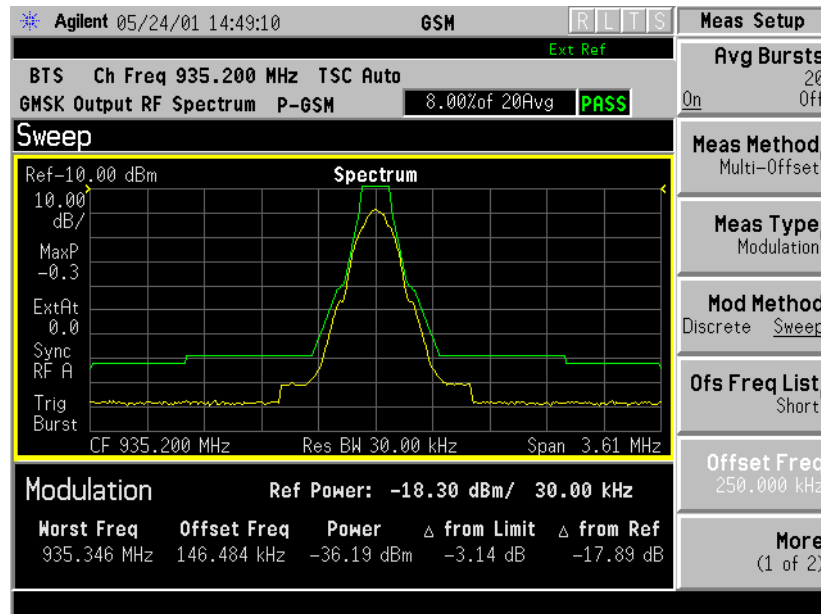

Figure 3-14 GMSK ORFS Result Example (Short List)
 Modulation View

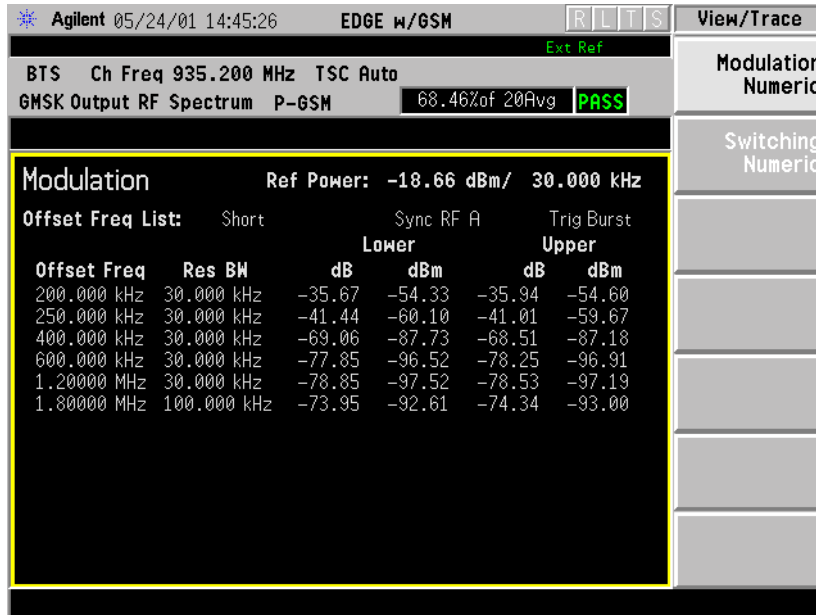
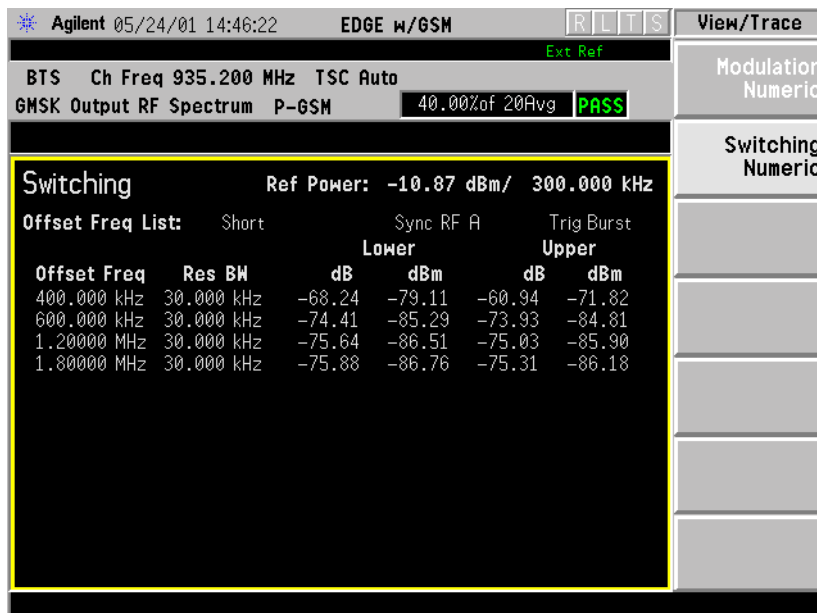

Figure 3-15 GMSK ORFS Result Example (Short List)
 Switching View



Changing the Measurement Setup

Table 3-4 Output RF Spectrum Measurement Defaults

Measurement Parameter	Factory Default Condition
Avg Bursts	20 On
Avg Mode	Repeat
Meas Method	Multi-Offset
Meas Type	Modulation
Ofs Freq List	Short
Offset Freq (when single offset is selected)	250.000 kHz
Trig Source	RF Burst
Burst Sync (information only)	RF Amptd
Fast Avg	On
Advanced	
Mod Avg	Log-Pwr Avg (Video)
Switching Avg (information only)	Max of Peak
Direct Time Break Freq	600.000 kHz
Modulation Meas BWs	
Carrier RBW	30.000 kHz
<1800 kHz Offset RBW	30.000 kHz
≥1800 kHz Offset RBW	100.000 kHz
VBW/RBW Ratio (information only)	1
Switching Meas BWs	
Carrier RBW	300.000 kHz
<1800 kHz Offset RBW	30.000 kHz
≥1800 kHz Offset RBW	30.000 kHz
VBW/RBW Ratio (information only)	3

NOTE

Parameters under the **Advanced** key seldom need to be changed. Any changes from default values may result in invalid measurement data.

Make sure the Output RF Spectrum measurement is selected under the **Measure** menu. Press the **Meas Setup** key to access a menu which allows you to modify the averaging and trigger source for this measurement (as described in the “[Measurement Setup](#)” on page 71 section at the beginning of this chapter). In addition, the following output RF spectrum measurement parameters can be modified:

- **Measure** - accesses a menu to choose the measurement mode.
 - Multi-Offset** - automatically makes measurements at all offset frequencies in the selected list (**Standard**, **Short**, or **Custom**). (See table below.) Press the **Ofs Freq List** key to select a list of offsets to measure.
 - Single Offset (Examine)** - makes a measurement at a single offset frequency as set by the **Offset Freq** softkey.
- **Meas Type** - accesses a menu to choose the measurement type.
 - Mod & Switch** - will perform both Modulation and Switching measurements.
 - Modulation** - measures the spectrum due to the 0.3 GMSK modulation and noise.
 - Switching** - measures the spectrum due to switching transients (burst ramping).
 - Full Frame Modulation (FAST)**- improves measurement speed by acquiring a full frame of data prior to performing the FFT calculation. This feature can only be used when all slots in the transmitted frame are active. When **Full Frame Modulation (FAST)** is selected only the multi-offset measurement method can be used; therefore the **Meas Method** defaults to multi-offset and the **Meas Method** key is grayed out, and the **Single Offset** feature is grayed out and not available.

- **Ofs Freq List** - accesses a menu to choose the offset frequency list. Select a **Standard**, **Short**, or **Custom** list as shown in the table below.

List	Modulation Offsets (kHz)	Switching Transients Offsets (kHz)
Standard	100, 200, 250, 400, 600, 800, 1000, 1200, 1400, 1600, 1800, 3000, 6000	400, 600, 1200, 1800
Short	200, 250, 400, 600 1200, 1800	400, 600, 1200, 1800
Custom	User-defined list that specifies: Offset Freq, RES BW, Limit Offsets, Meas Type, Initialized to be the same as the standard list Mod RBW, SW Trans RBW (currently settable only by remote commands)	400, 600, 1200, 1800

- **Offset Freq** - Only available when **Measure** is set to **Single Offset (Examine)**. Offset frequencies can be entered using the Data Entry keys.
- **Trig Source** - in this measurement, trigger source and burst sync are linked. Refer to the explanation under **Burst Sync**.
- **Burst Sync** - Synchronization is different on ORFS compared to other measurements. Since offsets may be very low power and acquired using very narrow filters, the burst edges are not well defined and there certainly is not enough information to perform a demodulation. Therefore all synchronization is performed on the carrier. The timing reference ("T0") is then re-used on the offsets. Since "T0" on the carrier is determined with respect to the trigger point, the trigger point on the offsets is very important. Once "T0" is determined, the 50% and 90% points can be found.

Therefore, the trigger must be synchronous with respect to a rising edge of a burst. The RF Burst trigger will do this if the offset is within about 7 MHz of the carrier. Remember that since the RF Burst trigger is wideband, the carrier will still cause the signal to trigger. Assuming the trigger threshold remains constant, the trigger with respect to the burst will remain constant. Since the Frame Trigger uses an internal frame timer (clock), its period is set so that it occurs synchronously with respect to the transmitting frame. If an external trigger is used, it is important that it is synchronous with the burst.

Because of these requirements, only the trigger source can be selected while the measurement selects the burst sync type based on the trigger source.

Trigger Source	Measurement Defined Burst Sync
Free Run	None
RF Burst	RF Amplitude
Ext Front	External
Ext Rear	External
Frame	Training Sequence

NOTE

Video trigger source is not allowed, because when the instrument is tuned to offset frequencies away from the carrier, the video trigger threshold will not be reached (due to the low power level of the offset.)

- **Fast Avg** - Fast averaging is a technique developed by HP/Agilent. The GSM standard specifies 50% to 90% portion of the burst, excluding the midamble, be measured in 50 averages. Since most offsets are measured in a 30 kHz filter, there is a lot of variation from burst to burst, hence the averaging.

The fast average method makes use of the 10% to 90% portion of the burst, excluding the midamble. The 10% to 50% portion of the burst has statistically the same average power as the 50% to 90%. Therefore, measuring both portions from one burst is statistically the same as measuring 50% to 90% from two bursts. Now, two averages are completed with one burst. When averaging is turned on, this will double the speed of the measurement.

This method is only applicable on the modulation portion of the test, and only when averaging is enabled. The method is not available when Modulation and Switching are done at the same time.

- **Advanced** - accesses a menu with the following keys:
 - **Mod Avg** - choose between:
 - Pwr Avg (RMS)**
 - Log-Pwr Avg (Video)**
 - **Switching Avg** - information only. Averaging is fixed at maximum of peak.
 - **Modulation Meas BWs** - accesses a menu with the following selections:
 - Carrier RBW**
 - <1800 kHz Offset RBW**
 - >=1800 kHz Offset RBW**
 - VBW/RBW Ratio** - information only. Bandwidth ratio is fixed at 1.
 - **Switching Meas BWs** - accesses a menu with the following selections:
 - Carrier RBW**
 - <1800 kHz Offset RBW**
 - >=1800 kHz Offset RBW**
 - VBW/RBW Ratio** - information only. Switching ratio is fixed at 3.

- **Direct Time Break Freq** - Selects the transition frequency (the first offset frequency) where the Direct Time Domain method is used instead of the FFT method. The Direct Time Domain offers a high dynamic range and is faster for measuring at a few offset frequencies. The FFT method has a moderate dynamic range (generally sufficient when the RBW = 30 kHz). It is much faster for measuring at many offset frequencies

Changing the View

If the Multi-Offset measurement has been chosen and the Meas Type is Mod & Switch, pressing the **View/Trace** key will allow you to select the desired view of the current measurement. If the Meas Type is Modulation, the **Switching Numeric** view is unavailable. If the Meas Type is Switching, the **Modulation Numeric** view is unavailable. See [Figure 3-14 on page 100](#) for the modulation numeric view. See [Figure 3-15 on page 100](#) for the switching numeric view.

If the Single Offset measurement has been chosen, the **Modulation Numeric** and the **Switching Numeric** softkeys are unavailable (grayed out) as both modulation and switching results are always displayed.

Troubleshooting Hints

The Output RF Spectrum measurement, along with the Phase and Frequency Error measurement, can reveal numerous faults in the transmit chain, such as the I/Q baseband generator, filters & modulator.

Making the GMSK Tx Band Spur Measurement

Purpose

NOTE This measurement is designed for GSM. For EDGE Tx Band Spur measurements see [“Making the EDGE Tx Band Spur Measurement” on page 142.](#)

The Tx Band Spur measurement checks that the transmitter does not transmit undesirable energy into the transmit band. This energy may cause interference for other users of the GSM system.

Measurement Method

This is a base station only measurement. The transmitter should be set at its maximum output power on all time slots. This measurement is performed at RF channels B (bottom), M (middle), and T (top). Refer to the following table.

Band	Tx Band Edge (MHz)		BOTTOM		MIDDLE		TOP	
	Low	High	Freq (MHz)	ARFCN	Freq (MHz)	ARFCN	Freq (MHz)	ARFCN
P-GSM	935	960	935.200	1	947.600	63	959.800	124
E-GSM	925	960	925.200	975	942.600	38	959.800	124
R-GSM	921	960	921.200	955	940.600	28	959.800	124
DCS 1800	1805	1880	1805.20	512	1842.60	699	1879.80	885
PCS 1900	1930	1990	1930.20	512	1960.00	661	1989.80	810

The transmit band spectrum is measured in several frequency segments using resolution bandwidths as specified by the standard (see the list below).

Frequency Offset	Resolution Bandwidth
≥ 1.8 MHz and < 6 MHz and inside Tx band	30 kHz
≥ 6 MHz and inside Tx band	100 kHz

The mean transmit power is measured first using the “power-above-threshold” method (see the Transmit Power measurement for detail), and then used as a reference for the measurement limit lines if limits are used. The spectrums, which are below or above the carrier frequency and within the transmit band, are measured.

For each spectrum segment, the measurement looks for the spectrum peak closest to the limit and saves the data. The peak of all segments is reported as the `Worst Spur`. The amplitude difference from the peak to the limit line (Δ from Limit), and from the peak to the mean transmit power (Δ from Carrier) are displayed. The frequency difference from the peak to the carrier frequency (Offset Freq) is also displayed. If the peak goes above the limit line, the display will indicate `FAIL`. If the marker is on, the active marker is placed at the peak of the displayed segment.

Making the Measurement

NOTE

The factory default settings provide a GSM compliant measurement. For special requirements, you may need to change some of the settings. Press **Meas Setup, More (1 of 2), Restore Meas Defaults** at any time to return all parameters for the current measurement to their default settings.

Select the desired transmit band, (P-GSM, E-GSM, R-GSM, DCS 1800, or PCS 1900), as described in the section [“Changing the Mode Setup” on page 36](#). Select the desired ARFCN and center frequency as described in the section [“Changing the Frequency Channel” on page 41](#).

Press **Measure, Tx Band Spur** to immediately make Tx Band Spur the active measurement.

To change any of the measurement parameters from the factory default values, refer to the [“Changing the Measurement Setup” on page 77](#) section for this measurement.

Results

Figure 3-16 GMSK Tx Band Spur Result - Upper Segment

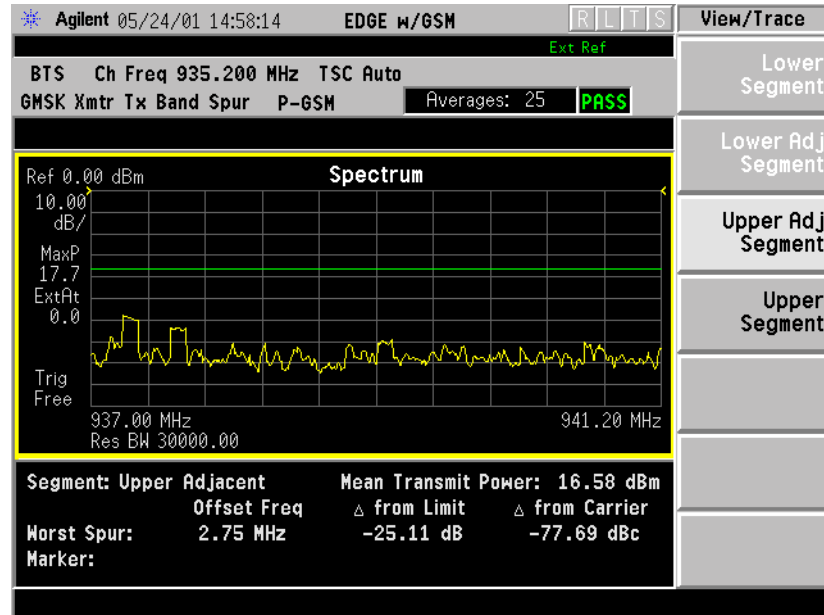

Changing the Measurement Setup

Table 3-5 Tx Band Spur Measurement Defaults

Measurement Parameter	Factory Default Condition
Avg Number	30 On
Avg Mode	Repeat
Avg Type	Maximum
Meas Type	Full
Limit	-36 dBm

Make sure the Tx Band Spur measurement is selected under the Measure menu. The Meas Setup key will access a menu which allows you to modify the averaging for this measurement. The following Tx Band Spur measurement parameters can be modified:

- **Meas Type** - select the measurement type from the following selections:

Full - In Continuous Measure, it repeatedly does full search of all segments.

Examine- In Continuous Measure, after doing one full search across all segments, it parks on the worst segment and continuously updates that segment.

- **Limit** - set the absolute or relative limit. The limit range is from -200 dBm to 100 dBm.

dBm - Absolute limit

dBc - Relative to Mean Transmit Power.

Changing the View

The **View/Trace** key will allow you to further examine the desired spectrum segment. Each of these choices selects a different part of the frequency spectrum for viewing:

Lower Segment	lower Tx band edge to -6 MHz offset from the channel frequency
Lower Adj Segment	-6 MHz to -1.8 MHz offset from the channel frequency
Upper Adj Segment	+1.8 MHz to +6 MHz offset from the channel frequency
Upper Segment	+6 MHz offset from the channel frequency to the upper Tx band edge

Troubleshooting Hints

Almost any fault in the transmitter circuits can manifest itself as spurious of one kind or another. Make sure the transmit band is correctly selected and the frequency is either the Bottom, Middle, or Top channel. The “Unexpected carrier frequency (BMT only)” message usually indicates the transmit band and/or carrier frequency is not correct. The “ADC overload -- unexpected carrier frequency” message usually indicates the selected channel frequency does not match the carrier frequency of the signal.

Making the EDGE Power vs. Time Measurement

Purpose

NOTE

This measurement is designed for EDGE. For GSM Power vs. Time measurements see [“Making the GMSK Power vs. Time Measurement” on page 79](#).

Power vs. Time measures the mean transmit power during the “useful part” of GSM bursts and verifies that the power ramp fits within the defined mask. Power vs. Time also lets you view the rise, fall, and “useful part” of the GSM burst. Using the “Multi-Slot” feature, up to eight slots in a frame can be viewed at one time.

GSM is a Time Division Multiple Access (TDMA) scheme with eight time slots, or bursts, per RF channel. If the burst does not occur at exactly the right time, or if the burst is irregular, then other adjacent timeslots can experience interference. Because of this, the industry standards specify a tight mask for the fit of the TDMA burst.

The Power vs. Time measurement provides masks for both BTS (Base Transceiver Station) and MS (mobile station). The timings are referenced to the transition from bit 13 to bit 14 of the midamble training sequence. For EDGE measurements, the 0 dB reference is determined by measuring the mean transmitted power during the middle 16 symbols of the midamble. You can also define a user configurable limit mask to apply to the measured burst using SCPI commands (refer to the [“Changing the Measurement Setup” on page 77](#)).

The GSM specifications defines the “useful part” of the normal GSM burst as being the 147 bits centered on the transition from bit 13 to bit 14 (the “T0” time point) of the 26 bit training sequence.

Measurement Method

The instrument acquires an EDGE signal in the time domain. The “T0” point and the useful part are computed. If Burst Sync is set to **Training Seq**, a $3\pi/8$ 8PSK demodulation is performed to find “T0”. If Burst Sync is set to **RF Amptd**, an approximation of “T0” will be used without performing a demodulation. The average power in the useful part is then computed and displayed, and the EDGE limit mask is applied. The measurement displays `PASS` when the burst fits within the bounds of the mask.

Making the Measurement

NOTE

The factory default settings provide a GSM standard compliant measurement. For special requirements, you may need to change settings. Press **Meas Setup, More (1 of 2), Restore Meas Defaults** at any time to return all parameters for the current measurement to their default settings.

Press **Measure, Pwr vs Time** to activate the power vs. time measurement.

Press **Frequency** to select an ARFCN channel or to enter a numeric value for the center frequency.

There are five keys that are frequently used to change power vs. time measurement settings. These are the **Timeslot, Burst Type, and TSC(Std)** keys located in the **Frequency** menu, and the **Trig Source** and **Burst Sync** keys located in the **Meas Setup** menu.

First, press **Trig Source**. The trigger source determines how the analyzer acquires a frame of data. If **Ext Front** or **Ext Rear** is selected an external, known reference in time will be provided for the data acquisition. If **RF Burst** is selected the rising edge of a burst will be used to initiate data acquisition.

Once data is acquired, the time record is interpreted as a sequence of eight slots. When an **Ext Front** or **Ext Rear** trigger source is selected, the trigger is assumed to be positioned near the beginning of the base station's timeslot. However, if the external trigger is more than 25% away from the burst, the analyzer will not identify the burst and will fail to place a mask on it. If the external trigger is too far away from the burst, you can compensate for this by entering a value for the external trigger delay to bring the burst back into the alignment range of the mask. When the external trigger is not coincident in time with the beginning of the base station's timeslot, press **Mode Setup**, then use the **Trigger** key to select the trigger; once the trigger is selected the **Delay** key will allow you to enter a value for trigger delay.

When **Trig Source** is set to **RF Burst**, data acquisition is delayed until the rising edge of an active timeslot burst. The issue of timeslot tolerance will then apply to any subsequent active time bursts within the frame. Thus, the analyzer uses the rising edge of the RF burst to define the beginning of the first timeslot of the data record.

The analyzer does not perform the protocol analysis that is necessary to identify which absolute slot number a frame is triggering on. If it is necessary to position the measurement on an absolute slot within the GSM frame, an external trigger must be used. As an alternative, a burst of interest can be identified by placing a unique training sequence in it, and setting **TSC(Std)** to manual; this requires that you are able to configure the burst to contain a specified training sequence.

When **Burst Sync** is set to **Training Seq** the analyzer demodulates the burst to identify the training sequence and bit timing, so it can accurately position the limit mask according to the standard. In this case, the **Burst Type** setting (the choices are **Normal**, **Sync**, and **Access**) tells the analyzer demodulation algorithm which burst bit structure should be used.

If **Burst Sync** is set to **RF Amptd**, demodulation is not used and the analyzer then positions the mask in relation to the rising edge of the RF burst.

The timeslot feature is an offset feature that is used to select the “burst of interest”. The “burst of interest” represents the portion of the acquired data record that receives analysis for interpretation as a valid burst; this is the burst to which a limit mask is applied and for which power calculations are generated. When the multi-slot view is selected, all slots in the view are tested for application of the limit mask, but the burst of interest is the one that will be indicated in blue text in the multi-slot table.

For example, if **Timeslot** is set to **On** and 3 is selected, the burst of interest will be offset by 3 slots from the beginning of the acquired time record, and the limit mask will be applied to this burst. If the selected timeslot attempts to locate a burst of interest where no burst is active, the mask application will fail. Timeslot functions as a time pointer offset in the acquired data record, regardless of the **Trig Source** setting.

Once determined, the burst of interest will be demodulated if **Burst Sync** is set to **Training Seq**. **TSC(Std)** applies only when **Burst Sync** is set to **Training Seq**.

When **TSC(Std)** is set to manual, demodulation will search for that specific training sequence number. If it is not found, a limit mask will not be applied, and an error will be reported. When **TSC(Std)** is set to **Auto**, demodulation will search the burst of interest for any of the eight standard training sequences, and use it for to find the true center of the burst so the mask can be applied accurately.

Making Multi-Slot Measurements

First set **Meas Time** to the number of slots you want to view, then activate the **Multi-Slot** view, which is found in the **View/Trace** menu.

You can use the following method to ensure that timeslots 0 - 7 in the transmitted frame correlate with timeslots 0 - 7 as viewed in the transmitter tester:

- Use an external trigger. The Agilent ESG signal generator series, for example, has an “event 1” rear panel output which triggers at the beginning of the frame. Connect the trigger from the signal generator to an external trigger input connector on the transmitter tester, then select the appropriate connector using the **Trigger Source**

key in the **Meas Setup** menu.

Selecting the Burst of Interest

The burst of interest is indicated in blue text in the table shown below the multi slot view. Press the **Burst** view key to view the burst of interest.

- If a timeslot contains a burst with a standard training sequence that is unique to the frame, the specified training sequence can be used to select the timeslot in which the burst of interest occurs. Set **Trigger** to **RF Burst**, set **Burst Sync** to **Training Seq**, and in the **Freq/Chan** menu set **Timeslot** to **OFF**. Then set **TSC (Std)** to **Man** (manual) and enter the training sequence number.
- If only one timeslot in a given frame contains a burst with a standard training sequence, then the specified training sequence can be used to select the timeslot in which the burst of interest occurs. Set **Trigger** to **RF Burst**, **Burst Sync** to **Training Seq**, and in the **Freq/Chan** menu set **Timeslot** **OFF**. Then set **TSC (Std)** to **Auto** and the trigger will automatically search through the available standards for a matching training sequence number.

Results

The views available under the **View/Trace** menu are **Burst**, **Rise & Fall**, and **Multi-Slot**. See [“Changing the View” on page 119](#).

Information shown in the left margin of the displays include:

- **MaxP** - This is total input power allowed for the measurement. This value is coupled to the internal **RF Input Atten** setting.
- **ExtAt** - This value reflects the **External RF Atten** setting.
- **Sync** - The **Burst Sync** setting used in the current measurement
- **Trig** - The **Trigger Source** setting used in the current measurement

The Current Data displayed at the bottom of the **Burst** and **Rise & Fall** views include:

- **Max Pt.** - Maximum signal power point in dBm
- **Min Pt.** - Minimum signal power point in dBm
- **Burst Width** - Time duration of burst at -3 dB power point (half-power)
- **Mask Ref Pwr Midamble** - The Mask Reference Power is the average power in dBm of the middle 16 symbols in the midamble. The times displayed are the corresponding start and stop times of the middle 16 symbols.
- **1st Error Pt** - (Error Point) The time (displayed in ms or μ s)

indicates the point on the X Scale where the first failure of a signal was detected. Use a marker to locate this point in order to examine the nature of the failure.

The table in the lower portion of the multi-slot view shows the output power in dBm for each timeslot, as determined by the integer (1 to 8) entered in the **Meas Setup, Meas Time** setting. Output power levels are presented for the active slots; a dashed line will appear for any slot that is inactive. The timeslot that contains the burst of interest is highlighted in blue.

Figure 3-17 EDGE Power vs. Time Result - Burst View

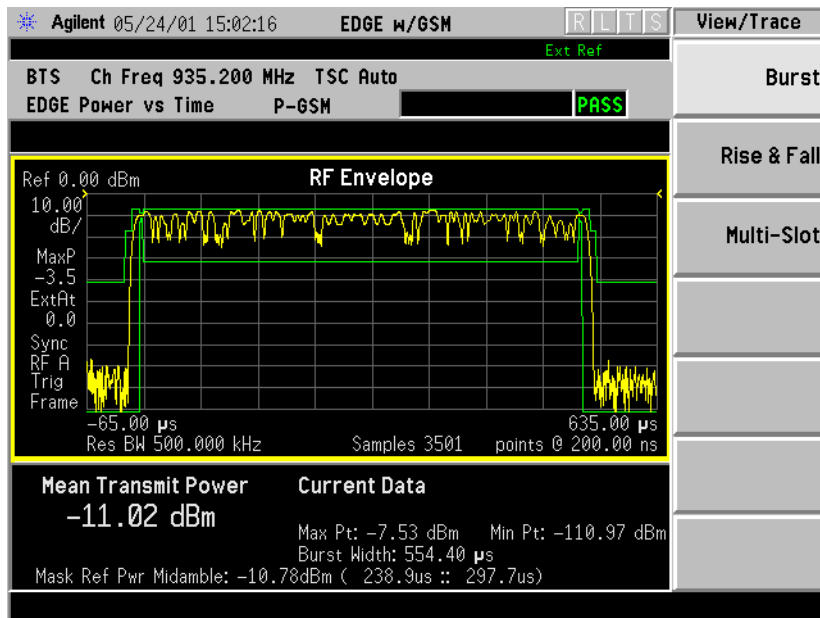

Figure 3-18 EDGE Power vs. Time Result - Rise & Fall View

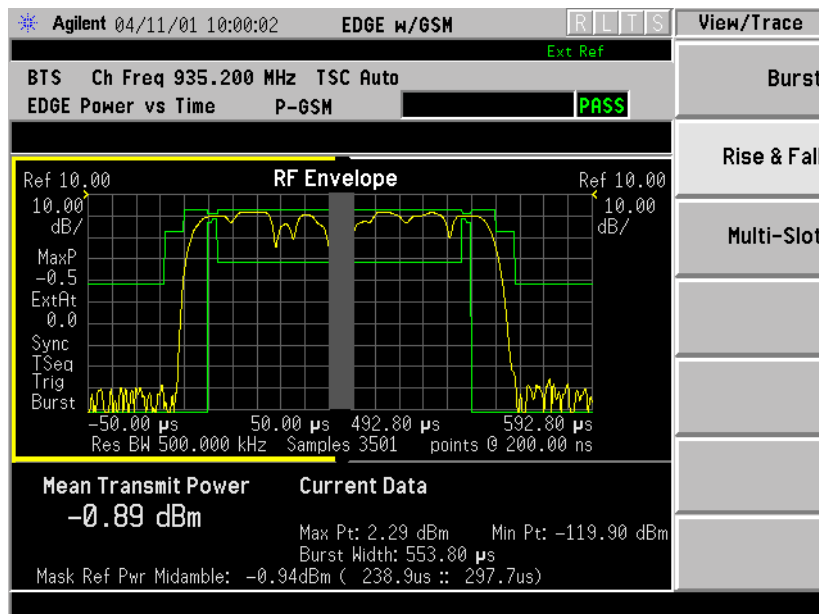
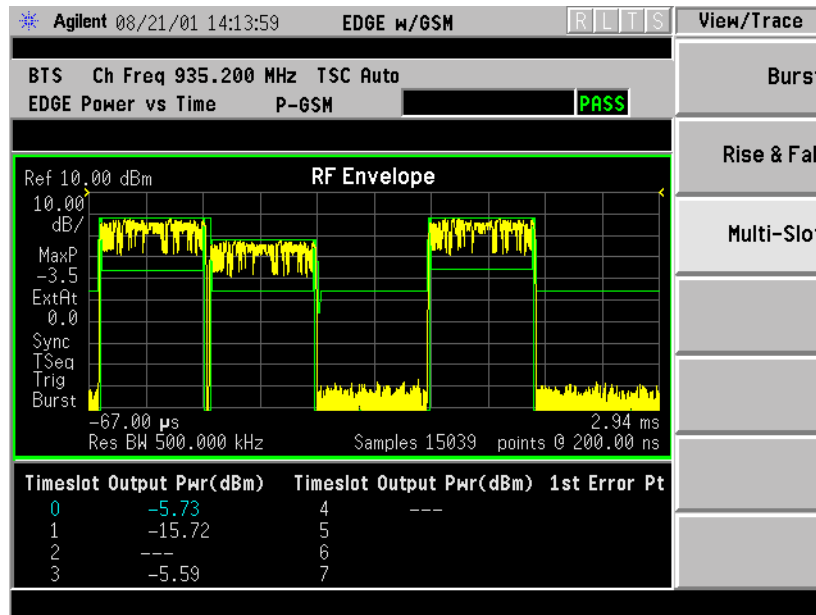

Figure 3-19 EDGE Result - Multi-Slot View



Changing the Measurement Setup

Table 3-6 EDGE Power vs. Time Measurement Defaults

Measurement Parameter	Factory Default Condition
Avg Bursts	10 Off
Avg Mode	Exp
Avg Type	Pwr Avg (RMS)
Meas Time	1 Slot
Timeslot	0
Trig Source	RF Burst (Wideband)
Burst Sync	Training Seq
Advanced	
RBW Filter	Gaussian
Res BW	500.000 kHz

NOTE Parameters that are under the **Advanced** key seldom need to be changed. Any changes from the default values may result in invalid measurement data.

Make sure the EDGE Power vs. Time measurement is selected under the **Measure** menu. The **Meas Setup** key will access a menu which allows you to modify the averaging, trigger source, and burst sync for this measurement (as described in the “[Measurement Setup](#)” section at the beginning of this chapter). In addition, the following power vs. time measurement parameters can be modified:

- **Pwr Cntrl Lvl** - used to indicate the output power of the transmitter; in MS testing transmitter output power variations will affect the mask (in BTS testing the mask is not affected). The appropriate power level for measuring the device under test will correspond with the transmitter power control level setting. Enter a value between 0 and 40.
- **Meas Time** - allows you to measure more than one timeslot. Enter a value in integer increments of “slots” with a range of 1 to 8. The actual measure time in μs is set somewhat longer than the specified number of slots in order to view the complete burst.

- **Advanced** - accesses a menu to change the following parameters:
 - RBW Filter** - chooses the type of filter, either **Gaussian** or **Flat** (Flatop). Gaussian is the best choice when looking at the overall burst or the rising and falling edges, as it has excellent pulse response. If you want to precisely examine just the useful part of the burst, choose **Flat**.
 - Res BW** - sets the resolution bandwidth.

Power vs. Time Custom Masks

For the Power vs. Time measurement, you can define a user configurable limit mask to apply to the measured burst. This feature can only be accessed via SCPI commands. Refer to the SENSE:EEVM commands in chapter 4.

Changing the View

The **View/Trace** key accesses a menu that allows you to select the desired view of the measurement from the following selections:

- **Burst** - views the entire burst of interest as determined by the current trigger source, burst sync, training sequence, and timeslot settings. To view a different burst of interest you must set these parameters for the selected timeslot. To view multiple slots use the **Multi-Slot** key described below. See [Figure 3-17 on page 116](#)
- **Rise & Fall** - zooms in on the rising and falling portions of the burst being tested. See [Figure 3-18 on page 116](#).

NOTE

The limit test will still be performed on the entire burst (viewed using the **Burst** menu) when **Rise & Fall** is selected.

- **Multi-Slot** - views the entire sweep as specified by the current **Meas Time** setting. Power levels for each active slot are listed in a table below the timeslot display. Also shown in the table under **1st Error Pt.** is the point in time at which the signal level first exceeds the limit; this will help identify the slot where a failure first occurs. See [Figure 3-19 on page 117](#).

Use the **Meas Time** key located in the **Meas Setup** menu to select up to eight slots. Use the **Timeslot** and **TSC** keys in the **Frequency/Channel** menu to select the slot you wish to activate. Setting **Timeslot** to **ON** and selecting a specific slot results in activating a measurement of that slot only (**Timeslot On** can be used to isolate a failure to a specific slot). When **Timeslot** is set to **OFF**, all active slots are tested against the mask.

Using a signal generator you can synchronize the multi-slot view

so the frame (or portion of the frame) you are viewing starts with the slot you have selected. See “[Making Multi-Slot Measurements](#)” on page 81.

You can switch from the multi-slot view directly to the burst or rise and fall views of the slot that is currently active. The **Scale/Div** key under the **Span/Y Scale** menu can be used to enlarge your view of this signal.

Changing the Display

The **Display** key will allow you to turn the limit mask on and off. This also disables the mask limit test, but still calculates the power in the useful part.

Troubleshooting Hints

If a transmitter fails the EDGE Power vs. Time measurement this usually indicates a problem with the units output amplifier or leveling loop.

Making the EDGE EVM Measurement

Purpose

EVM (Error Vector Magnitude) is the measure of modulation quality for EDGE. Since EDGE uses $3\pi/8$ PSK modulation, the transmitter's phase, frequency, and amplitude accuracy are critical to the communications system's performance. EVM also ultimately affects range.

EDGE receivers rely on the quality of the $3\pi/8$ PSK modulation signal to achieve the expected carrier to noise ratio. A transmitter with high EVM will often still be able to support phone calls during a functional test. However, it will tend to provide difficulty for mobiles trying to maintain service at the edge of the cell with low signal levels or under difficult fading and Doppler conditions.

Measurement Method

EVM is measured by calculating the difference between the actual EVM of the transmitted signal and the EVM of a theoretical, ideal signal; this theoretical signal is derived mathematically from data sampled from the transmitted signal.

The EVM measurement allows you to view error results numerically and graphically in the instrument display. The graph windows display `EVM Phase Error` and `Mag Error`. The text window displays `EVM in % rms,% peak at the highest symbol number, and 90% EVM; Mag Error in % rms; Phase Error in degrees; Freq Error in Hz; Droop in mdB/symbol (Droop is stated in dB across the 142 symbol burst; it also allows you to view demodulated symbols), and I/Q Offset in dB.`

Making the Measurement

NOTE

The factory default settings provide a GSM standards compliant measurement. For special requirements, you may need to change some of the settings. Press **Meas Setup, More (1 of 2), Restore Meas Defaults** at any time to return all parameters for the current measurement to their default settings.

Select the desired center frequency and burst type as described in “[Radio](#)” on page 36. Select the timeslot as described in “[Changing the Frequency Channel](#)” on page 41

Press **Measure, EVM** to immediately make the error vector magnitude measurement.

To change any of the measurement parameters from the factory default values, refer to “[Changing the Measurement Setup](#)” on page 123 for this measurement.

Results

The next figure shows an example of measurement result with the graphic and text windows. The measured summary data is shown in the left window and the dynamic vector trajectory of the I/Q demodulated signal is shown as a polar vector display in the right window.

Figure 3-20 EDGE EVM Result - Polar Vector View

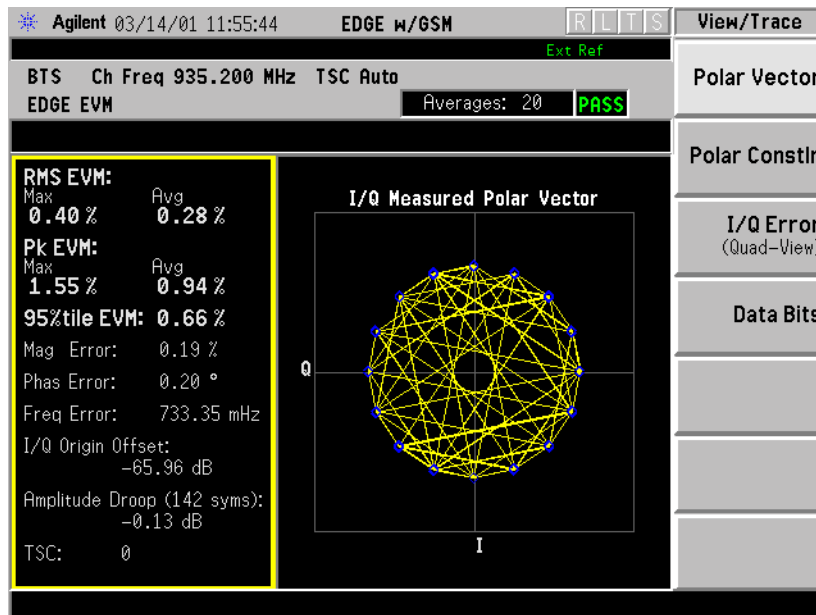

Changing the Measurement Setup

The next table shows the factory default settings for error vector magnitude measurements.

Table 3-7 Error Vector Magnitude Measurement Defaults

Measurement Parameter	Factory Default Condition
Avg Number	10, On
Avg Mode	Exponential
Trigger Source	RF Burst (Wideband)
Burst Sync	Training Seq
View/Trace	I/Q Measured Polar Vector
Limit Test	On
Limits (BS): RMS EVM	7%, normal 8%, extreme
Limits (MS): RMS EVM	9%, normal 10%, extreme
Limits (BS): Peak EVM	22%, normal 22%, extreme
Limits (MS): Peak EVM	30%, normal 30%, extreme
Limits (BS): 95th percentile EVM	11%, normal 11%, extreme
Limits (MS): 95th percentile EVM	15%, normal 15%, extreme
Limits: Origin Offset	-20 dB

Make sure the **Error Vector Magnitude (EVM)** measurement is selected under the **Measure** menu. The **Meas Setup** key accesses a menu which allows you to modify the averaging, trigger source and burst sync for this measurement as described in “[Measurement Setup](#)” earlier in this chapter.

Changing the View

The **View/Trace** key accesses the menu which allows you to select the desired measurement view from the following selections:

- **Polar Vector** - The measured summary data is shown in the left window and the dynamic vector trajectory of the I/Q demodulated signal is shown as a vector display in the right window. The polar vector view presents a constantly changing display. See [Figure 3-20](#)

Making Measurements
Making the EDGE EVM Measurement

on page 122.

- **Polar Constln** - The measured summary data is shown in the left window and the dynamic constellation of the I/Q demodulated signal is shown as a polar display in the right window. See [Figure 3-21 on page 125](#).
- **I/Q Error (Quad-View)** - Four display windows show EVM, Mag Error and Phase Error graphs, and the EVM summary data text.

Figure 3-21 EDGE EVM Result- Polar Constln

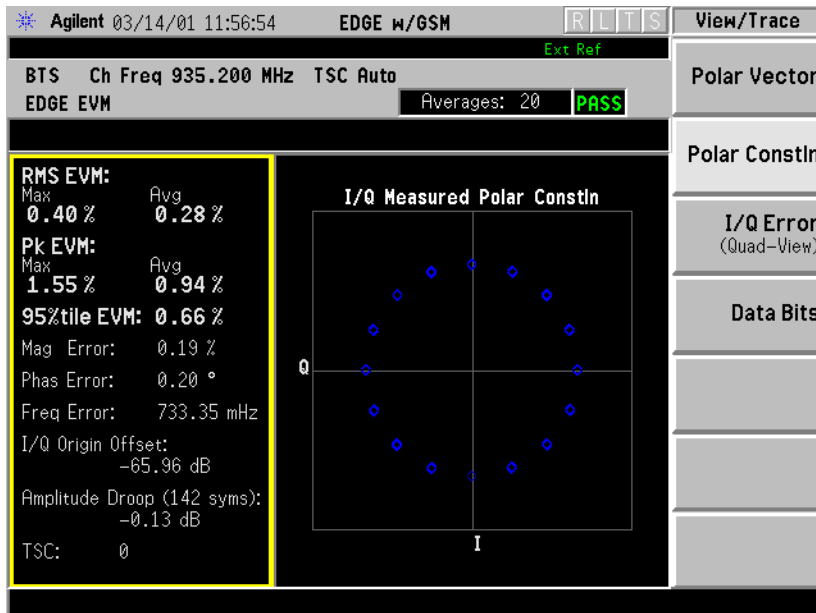
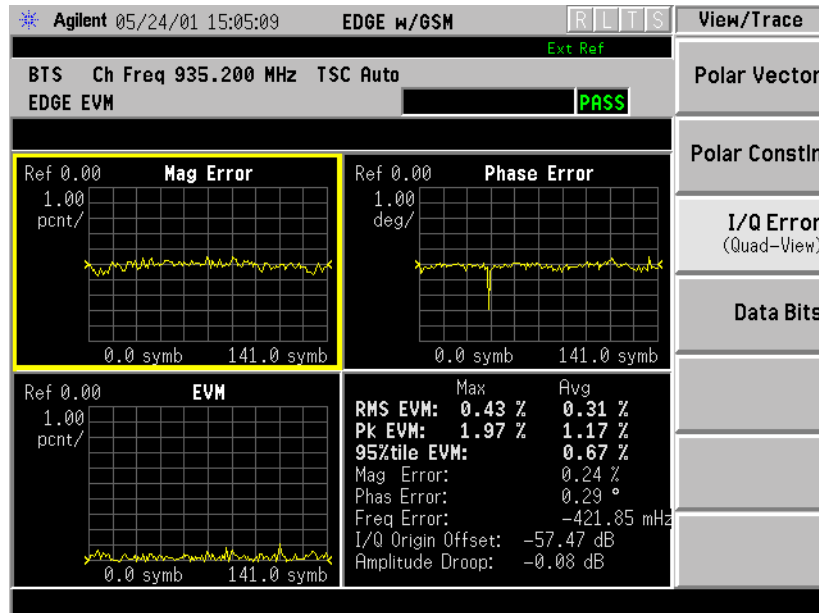
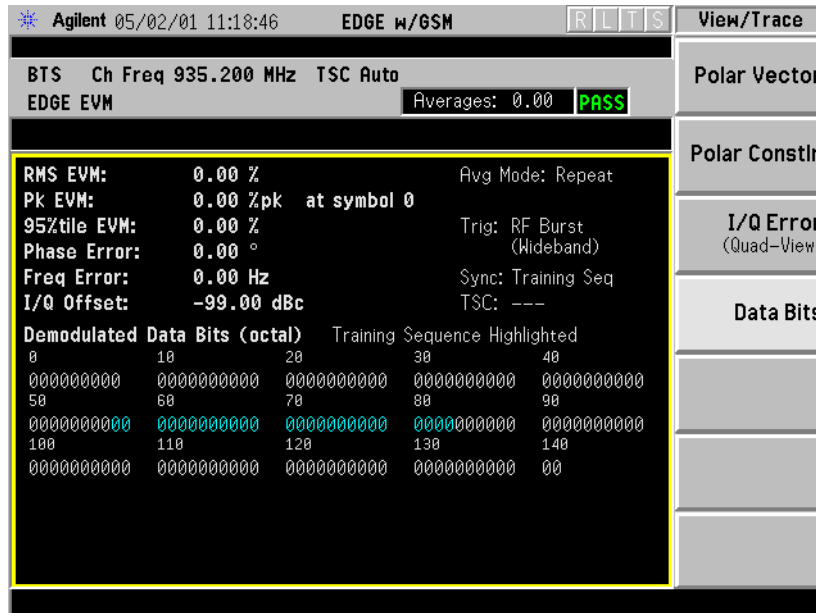

Figure 3-22 EDGE EVM Result - I/Q Error (Quad View)



- **Data Bits** - See [Figure 3-23](#). Provides a view of the numeric results and data bits (in octal) with the sync word (TSC) highlighted.

Figure 3-23 EDGE EVM Result - Data Bits View



Changing the Display

The **Display** key accesses the menu to allow the following selections for changing the graph displays:

- **Symbol Dots** - Allows you to toggle the symbol dots between **On** and **Off**. The default setting is **On**.

When either EVM, Phase Error or Mag Error window is active in the I/Q Error (Quad-View) display, the **Span X Scale** key accesses the menu to allow the following selections:

- **Scale/Div** - Allows you to define the horizontal scale by changing the symbol value per division. The range is 1 to 500K symbols per division. The default setting is 14.1 symbols per division for BTS and MS device types.
- **Ref Value** - Allows you to set the symbol reference value ranging from 0 to 500K symbols. The default setting is 0.
- **Ref Position** - Allows you to set the reference position to either **Left**, **Ctr** (center) or **Right**. The default setting is **Left**.
- **Scale Coupling** - Allows you to toggle the scale coupling function between **On** and **Off**. The default setting is **On**. This function automatically determines the scale per division and reference value by the magnitude of the measurement results.

When EVM, Phase Error, or Mag Error windows are active in the I/Q Error (Quad-View) display, the **Amplitude Y Scale** key accesses a menu which allows the following selections:

- **Scale/Div** - Allows you to define the vertical scale by changing the value per division, with units, ranges, and default values depending on which display window is active.
 - **Mag Error Window** - Units are in Percent, range is from 0.1% to 50.0%, the default is 1.00%.
 - **Phase Error Window** - Units are in degrees, range is from 0.01 degrees to 3000 degrees, the default is 1.00 degrees.
 - **EVM Window** - Units are in Percent, range is from 0.1% to 50.0%, the default is 1.00%

Since the **Scale Coupling** default is set to **On**, the value displayed in this condition is automatically determined by the measurement results.

- **Ref Value** - Allows you to set the reference value, with units, ranges, and default values depending on which display window is active.
 - **Mag Error Window** - Units are in Percent, range is from -500.0% to 500.0%, the default is 0.00%.
 - **Phase Error Window** - Units are in degrees, range is from -36000.0 degrees to 36000.0 degrees, the default is 0.00 degrees.
 - **EVM Window** - Units are in Percent, range is from -500.0% to 500.0%, the default is 0.00%.
- **Ref Position** - Allows you to set the reference position to **Top**, **Ctr** (center) or **Bot** (bottom).
 - **Mag Error Window** - The default is **Ctr**.
 - **Phase Error Window** - The default is **Ctr**.
 - **EVM Window** - The default is **Top**.
- **Scale Coupling** - Allows you to toggle the scale coupling function between **On** and **Off**. The default setting is **On**. This function automatically determines the scale per division and reference value by the magnitude of the measurement results.

Troubleshooting Hints

Use the spectrum (frequency domain) measurement to verify that the signal is present and approximately centered on the display.

The data used for testing can have a detrimental effect on the EVM results, causing erratic or falsely high EVM, especially in the case of sending all 0 bits with the Trigger Source set to RF Burst. In that unique situation, better results will be obtained using Free Run or Video triggers.

Poor EVM indicates a problem at the I/Q baseband generator, filters, and/or modulator in the transmitter circuitry. The output amplifier in the transmitter can also create distortion that causes unacceptably high EVM. In a real system, poor EVM will reduce the ability of a receiver to correctly demodulate the signal, especially in marginal signal conditions. Poor EVM may also indicate that a measurement restart was not performed after the signal level was changed. Press **Restart** after a change in the input signal to ensure that an auto-attenuation adjustment is performed.

The I/Q Error Quad View display may be used to determine where demodulation errors are concentrated.

Making the EDGE Output RF Spectrum Measurement

NOTE This measurement is designed for EDGE. For the GSM Output RF Spectrum measurement see [“Making the GMSK Output RF Spectrum Measurement” on page 95](#).

Purpose

The Output RF Spectrum measurement is the EDGE version of the adjacent channel power (ACP) measurement. Either a single offset is measured with corresponding traces or up to 15 offsets are measured and a table is displayed. In spectrum due to modulation measurements a sweep spectrum display of -1.8 MHz to +1.8 MHz from the carrier can be viewed.

The output RF spectrum measurements determine the spectral energy emitted into the adjacent channels. Excessive amounts of energy spilling into an adjacent frequency channel could interfere with signals being transmitted to other MS or BTS. The measurements are divided into two main groups: spectrum due to the $3\pi/8$ 8PSK modulation and noise, and spectrum due to switching transients (burst ramping).

Since GSM is a TDMA format, RF power is being switched on and off depending on whether the actual burst is being transmitted. The switching of power causes spectral splatter at frequencies other than that being transmitted by the carrier. Fast transitions in the time domain causes switching transients that have high frequency content associated with them.

NOTE The default output RF spectrum measurements do not perform tests at frequency offsets greater than 1800 kHz from the carrier.

Measurement Method

In this measurement, the transmitter (source) is set to transmit a GSM frame at a given channel (frequency). The instrument acquires a time record at a particular offset from the channel being transmitted. The method of acquiring the time record is either a FFT/Inverse-FFT method, or a direct time domain (DTD) method, depending on the offset. These two methods and when they are used, will be described below. When the offset is zero, the instrument is said to be measuring the carrier. For a given offset frequency from the carrier, the transmitter must not exceed a certain power level relative to the carrier. The GSM specification defines the offsets and their maximum absolute and relative power levels.

The general steps in making the measurement are as follows:

- Acquire time record (using either FFT or DTD methods, described below)
- Synchronize for gating on the carrier - finds 50% and 90% portion of burst for Spectrum Due to Modulation portion of the test
- Measure power of the carrier
- Compare each offset power to reference to get relative power level

The method of acquiring the time record is dependent on accuracy and dynamic range. With no pre-ADC filter, signals in the entire IF bandwidth of the instrument are digitized by the analog to digital converter (ADC). The setting of the ADC gain is based on the peak level at its input. The dynamic range (noise floor) of the ADC is dependent on the gain selected. For the type of signal being measured, the highest energy within the IF bandwidth is at the carrier. Therefore, the lowest dynamic range (highest noise floor) of the ADC occurs when the full energy of the carrier is input to the ADC.

All offsets measured using the FFT method are done with the instrument tuned such that the carrier is at the center of the IF bandwidth. Therefore, the dynamic range of the offsets measured using the FFT method is the same as that for the carrier. The dynamic range requirement generally increases as the offset frequency increases. If the dynamic range requirement exceeds what is available by FFT method, the direct time domain (DTD) method utilizing the pre-ADC filter is used.

The **Direct Time Break Freq** key setting is the first offset frequency which is measured using the DTD method. Its range is determined by assuring no aliasing occurs on FFT offsets and that the dynamic range requirements are met.

The FFT method acquires a wideband signal (1.55 MHz) in a flattop filter. An FFT is performed to get the spectrum of the GSM signal. The resolution bandwidth filter can now be applied mathematically to the spectrum at multiple offsets, with an inverse-FFT performed on the data which passes the filter. In this way, multiple offsets are acquired from one time record and LO setting. Since the resolution bandwidth filter is a mathematical formula, it can be any shape and size, and is perfect. The transmitter tester uses the 5-pole synchronously tuned filter that is specified by the GSM standard.

The primary disadvantage to the FFT method is that the acquisition must include the carrier. The high energy of the carrier causes the ADC to range down, thus lowering the dynamic range. At large offsets, the dynamic range requirement is very challenging so the direct time domain (DTD) method is used. The LO is tuned to the particular offset and the pre-ADC filter is used to reduce the carrier. This allows the ADC to range up, giving higher dynamic range. The disadvantage to

this method is that each offset measured has its own time record acquisition and LO tune position, and this causes the measurement to slow down compared to FFT offsets. The 5-pole synchronously tuned filter is approximated by utilizing a digital Gaussian filter and setting its equivalent noise bandwidth to that of the 5-pole synchronously tuned filter. For these DTD offset frequencies, the filter has closer-to-ideal 5-pole behavior (< 1% tolerance) than does a 10% tolerance, 5-pole analog filter.

Regardless of how the time record is obtained for a particular offset, the power must be measured and compared to the reference power. There are two measurements for the test: output RF spectrum due to modulation and the output RF spectrum due to switching transients. The GSM standard specifies which offsets get which tests. In these two modes, the following conditions are met:

- In the output RF spectrum due to modulation measurement, the average value during at least 40 bits between bit 87 and 132 (approximately equivalent to the 50% to 90% portion of the burst, excluding midamble) is retained. The vertical lines mark the section of the burst over which the measurement is made. If multiple bursts are examined, an average of the average values is calculated. The relative power (difference between the average power of the burst at zero offset and the average power of the burst at the indicated offset) and the absolute power are displayed.
- In the output RF spectrum due to switching transients, the peak value of the whole frame is retained. The reference power of reference due to switching is the average power of the useful part of the burst with at least 300 kHz RBW. The relative power (difference between the mean transmit power of the burst at zero offset and the peak power of the burst at the indicated offset) and the absolute power are displayed.

The GSM standard specifies the tests are run on specified offsets from the carrier. The instrument identifies this as single offset or multiple offset modes. The measurement made in these two modes is the same, except that the multiple offset mode automatically makes the measurement at all the specified offsets frequencies and lists the results in a table at the end of the measurement.

In the output RF spectrum due to modulation measurement, setting the modulation method to discrete obtains results from specified offsets from the carrier as defined in the standard; the results are displayed in a table. When set to sweep, the measurement obtains results of a span extending to 1800 kHz from both sides of the carrier, measured in 10 kHz steps; the results are displayed as a spectrum.

The GMSK Phase and Frequency Error view shows a single-offset (Examine) trace for an entire GSM frame with timeslots 0, 2, and 6 turned on and timeslots 1, 3, 4, 5, and 7 turned off. The vertical bars show the portion used to measure power due to modulation.

Figure 3-24 EDGE ORFS Result - Frame in Single-Offset (Examine)

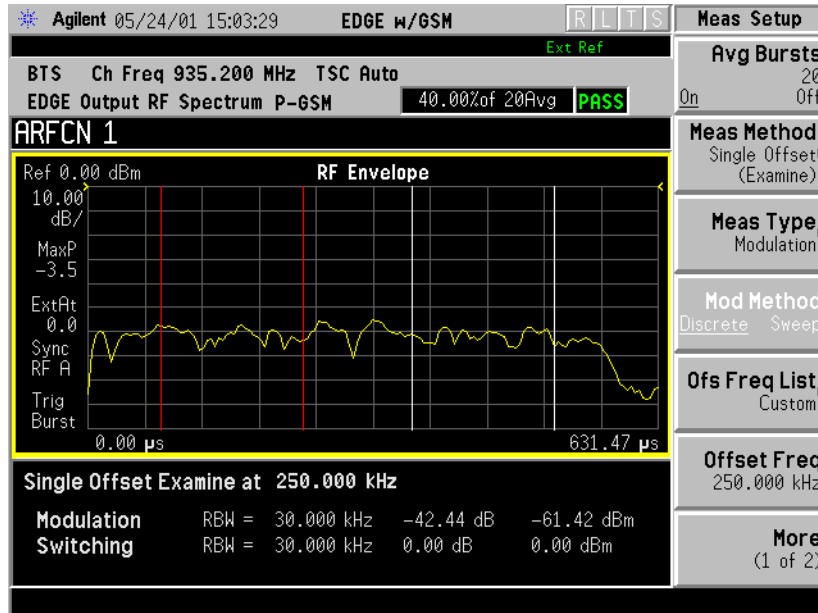
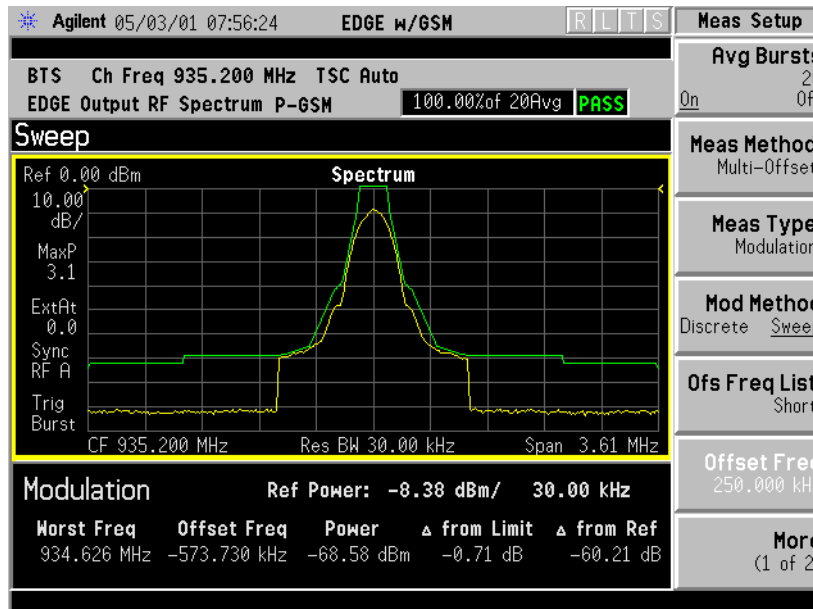

Figure 3-25 EDGE ORFS Result - Modulation Sweep Spectrum



The RF envelope trace is displayed. If averaging is turned on, the trace is then averaged with previous traces. For the modulation measurement, the user may select the type of trace averaging, either log-power averaged (Video) or power averaged (RMS). For the switching transients measurement, the peak of the traces is used. For modulation, the displayed value is the average of points within the vertical bars. For transients, the displayed value is the max of all points for all traces (Max of Peak) over the entire frame.

Making the Measurement

NOTE

The factory default settings provide a GSM compliant measurement. For special requirements, you may need to change some of the settings. Press **Meas Setup, More (1 of 2), Restore Meas Defaults** at any time to return all parameters for the current measurement to their default settings.

Select the desired ARFCN, center frequency, timeslot, burst type, and TSC (Training Sequence Code) as described in the section titled [“Changing the Frequency Channel” on page 41](#).

When **Training Sequence** is selected as the burst sync for this measurement, set the **Timeslot** selection to determine which timeslot to measure. For example, if **Timeslot** is set to 2, the measurement will be made on the timeslot number 2. Be careful when adding delay in the **Trigger setup**, as this measurement does not take into account trigger delay when checking for a valid burst. If there is sufficient delay added (usually more than 25% of a timeslot), the burst might not be detected.

Press **Measure, Output RF Spectrum** to immediately make Output RF Spectrum the active measurement.

To change any of the measurement parameters from the factory default values, refer to the [“Changing the Measurement Setup” on page 136](#) section for this measurement.

Results

Figure 3-26 EDGE ORFS Result - Example (Short List)
 Modulation View

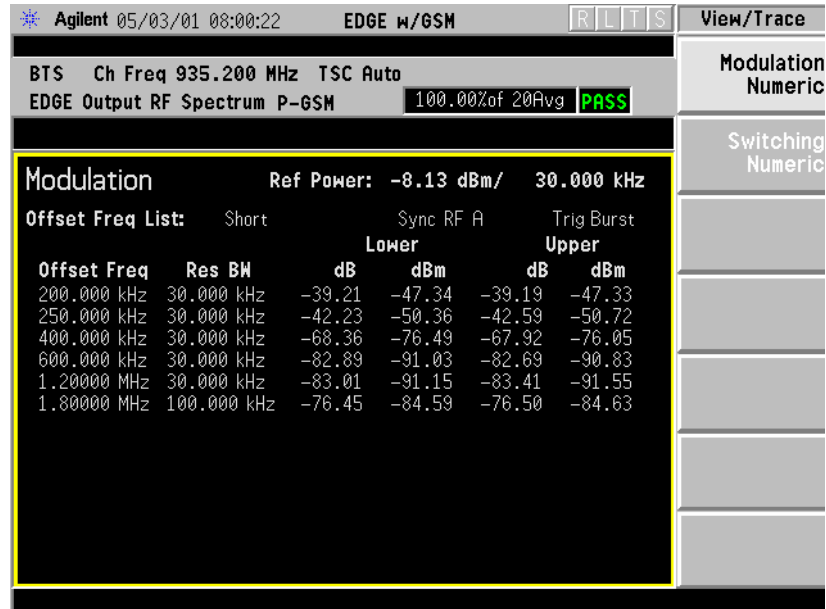
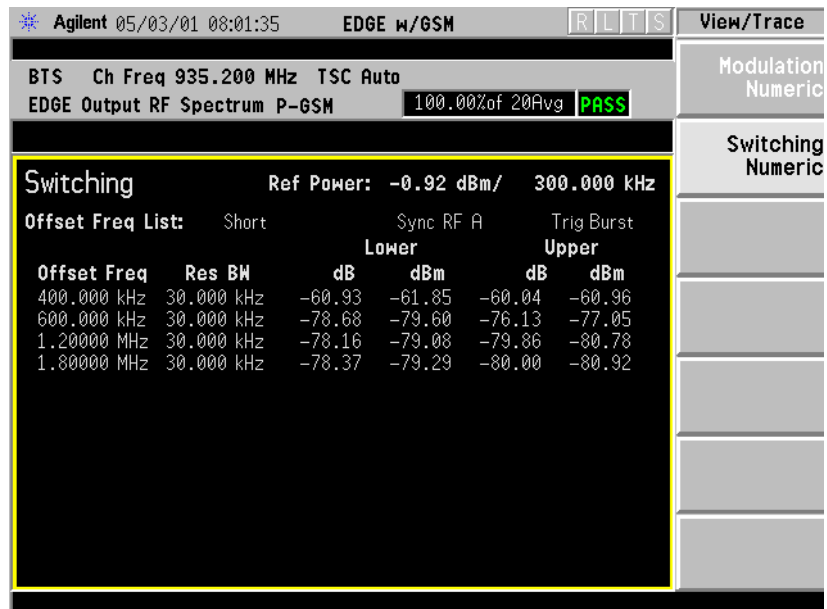

Figure 3-27 EDGE ORFS Result - Example (Short List)
 Switching View



Changing the Measurement Setup

Table 3-8 Output RF Spectrum Measurement Defaults

Measurement Parameter	Factory Default Condition
Avg Bursts	20 On
Avg Mode	Repeat
Meas Method	Multi-Offset
Meas Type	Modulation
Ofs Freq List	Short
Offset Freq (when single offset is selected)	250.000 kHz
Trig Source	RF Burst
Burst Sync (information only)	RF Amptd
Fast Avg	On
Mod Method	Discrete
Advanced	
Mod Avg	Log-Pwr Avg (Video)
Switching Avg (information only)	Max of Peak
Direct Time Break Freq	600.000 kHz
Modulation Meas BWs	
Carrier RBW	30.000 kHz
<1800 kHz Offset RBW	30.000 kHz
≥1800 kHz Offset RBW	100.000 kHz
VBW/RBW Ratio (information only)	1
Switching Meas BWs	
Carrier RBW	300.000 kHz
<1800 kHz Offset RBW	30.000 kHz
≥1800 kHz Offset RBW	30.000 kHz
VBW/RBW Ratio (information only)	3

NOTE Parameters under the **Advanced** key seldom need to be changed. Changes from default values may result in invalid measurement data.

Make sure the EDGE ORFS measurement is selected under the **Measure** menu. Press the **Meas Setup** key to access a menu which allows you to modify the averaging and trigger source for this measurement (as described in the “**Measurement Setup**” section at the beginning of this chapter). In addition, the following output RF spectrum measurement parameters can be modified:

- **Measure** - accesses a menu to choose the measurement mode.
 - Multi-Offset** - automatically makes measurements at all offset frequencies in the selected list (**Standard**, **Short**, or **Custom**). (See table below.) Press the **Ofs Freq List** key to select a list of offsets to measure.
 - Single Offset (Examine)** - makes a measurement at a single offset frequency as set by the **Offset Freq** softkey.
- **Meas Type** - accesses a menu to choose the measurement type.
 - Mod & Switch** - will perform both Modulation and Switching measurements.
 - Modulation** - measures the spectrum due to the 0.3 GMSK modulation and noise.
 - Switching** - measures the spectrum due to switching transients (burst ramping).
 - Full Frame Modulation (FAST)**- improves measurement speed by acquiring a full frame of data prior to performing the FFT calculation. This feature can only be used when all slots in the transmitted frame are active. When **Full Frame Modulation (FAST)** is selected only the multi-offset measurement method can be used; therefore the **Meas Method** defaults to multi-offset and the **Meas Method** key is grayed out, and the **Single Offset** feature is grayed out and not available.
- **Ofs Freq List** - accesses a menu to choose the offset frequency list. Select a **Standard**, **Short**, or **Custom** list as shown in the table below.

List	Modulation Offsets (kHz)	Switching Transients Offsets (kHz)
Standard	100, 200, 250, 400, 600, 800, 1000, 1200, 1400, 1600, 1800, 3000, 6000	400, 600, 1200, 1800
Short	200, 250, 400, 600 1200, 1800	400, 600, 1200, 1800

List	Modulation Offsets (kHz)	Switching Transients Offsets (kHz)
Custom	User-defined list that specifies: Offset Freq, RES BW, Limit Offsets, Meas Type, Initialized to be the same as the standard list (currently settable only by remote commands)	400, 600, 1200, 1800

- **Offset Freq** - Only available when **Measure** is set to **Single Offset (Examine)**. Offset frequencies can be entered using the RPG knob or the Data Entry keys.
- **Trig Source** - in this measurement, trigger source and burst sync are linked. Refer to the explanation under **Burst Sync**.
- **Burst Sync** - Synchronization is different on ORFS compared to other measurements. Since offsets may be very low power and acquired using very narrow filters, the burst edges are not well defined and there certainly is not enough information to perform a demodulation. Therefore all synchronization is performed on the carrier. The timing reference (“T0”) is then re-used on the offsets. Since “T0” on the carrier is determined with respect to the trigger point, the trigger point on the offsets is very important. Once “T0” is determined, the 50% and 90% points can be found.

Therefore, the trigger must be synchronous with respect to a rising edge of a burst. The RF Burst trigger will do this if the offset is within about 7 MHz of the carrier. Remember that since the RF Burst trigger is wideband, the carrier will still cause the signal to trigger. Assuming the trigger threshold remains constant, the trigger with respect to the burst will remain constant. Since the Frame Trigger uses an internal frame timer (clock), its period is set so that it occurs synchronously with respect to the transmitting frame. If an external trigger is used, it is important that it is synchronous with the burst.

Because of these requirements, only the trigger source can be selected while the measurement selects the burst sync type based on the trigger source.

Trigger Source	Measurement Defined Burst Sync
Free Run	None
RF Burst	RF Amplitude
Ext Front	External
Ext Rear	External
Frame	Training Sequence

NOTE

Video trigger source is not allowed, because when the instrument is tuned to offset frequencies away from the carrier, the video trigger threshold will not be reached (due to the low power level of the offset.)

- **Fast Avg** - Fast averaging is a technique developed by HP/Agilent. The GSM standard specifies 50% to 90% portion of the burst, excluding the midamble, be measured. Since most offsets are measured in a 30 kHz filter, there is a lot of variation from burst to burst, hence the averaging.

The fast average method makes use of the 10% to 90% portion of the burst, excluding the midamble. The 10% to 50% portion of the burst has statistically the same average power as the 50% to 90%. Therefore, measuring both portions from one burst is statistically the same as measuring 50% to 90% from two bursts. Now, two averages are completed with one burst. When averaging is turned on, this will double the speed of the measurement.

This method is only applicable on the modulation portion of the test, and only when averaging is enabled. The method is not available when Modulation and Switching are done at the same time.

- **Advanced** - accesses a menu with the following keys:
 - **Mod Avg** - choose between:
 - Pwr Avg (RMS)**
 - Log-Pwr Avg (Video)**
 - **Switching Avg** - information only. Averaging is fixed at maximum of peak.
 - **Modulation Meas BWs** - accesses a menu with the following selections:
 - Carrier RBW**
 - <1800 kHz Offset RBW**
 - >=1800 kHz Offset RBW**
 - VBW/RBW Ratio** - information only. Bandwidth ratio is fixed at 1.
 - **Switching Meas BWs** - accesses a menu with the following selections:
 - Carrier RBW**
 - <1800 kHz Offset RBW**
 - >=1800 kHz Offset RBW**
 - VBW/RBW Ratio** - information only. Switching ratio is fixed at 3.

- **Direct Time Break Freq** - Selects the transition frequency (the first offset frequency) where the Direct Time Domain method is used instead of the FFT method. The Direct Time Domain offers a high dynamic range and is faster for making measurements at a few offset frequencies. The FFT method has a moderate dynamic range (generally sufficient when the RBW = 30 kHz). It is much faster for measuring at many offset frequencies

Changing the View

If the Multi-Offset measurement has been chosen and the Meas Type is Mod & Switch, pressing the **View/Trace** key will allow you to select the desired view of the current measurement. If the Meas Type is Modulation, the **Switching Numeric** view is unavailable. If the Meas Type is Switching, the **Modulation Numeric** view is unavailable. See [Figure 3-26 on page 135](#) for the modulation numeric view. See [Figure 3-27 on page 135](#) for the switching numeric view.

If the Single Offset measurement has been chosen, the **Modulation Numeric** and the **Switching Numeric** softkeys are unavailable (grayed out) as both modulation and switching results are always displayed.

Troubleshooting Hints

The Output RF Spectrum measurement, along with the Phase and Frequency Error measurement, can reveal numerous faults in the transmit chain, such as the I/Q baseband generator, filters & modulator.

Making the EDGE Tx Band Spur Measurement

Purpose

NOTE This measurement is designed for EDGE. For GSM Tx Band Spur measurements see [“Making the GMSK Tx Band Spur Measurement” on page 107.](#)

The EDGE Tx Band Spur measurement checks that the transmitter does not transmit undesirable energy into the transmit band. This energy may cause interference for other users of the EDGE and GSM systems.

Measurement Method

This is a base station only measurement. The transmitter should be set at its maximum output power on all time slots. This measurement is performed at RF channels B (bottom), M (middle), and T (top). Refer to the following table.

Band	Tx Band Edge (MHz)		BOTTOM		MIDDLE		TOP	
	Low	High	Freq (MHz)	ARFCN	Freq (MHz)	ARFCN	Freq (MHz)	ARFCN
P-GSM	935	960	935.200	1	947.600	63	959.800	124
E-GSM	925	960	925.200	975	942.600	38	959.800	124
R-GSM	921	960	921.200	955	940.600	28	959.800	124
DCS 1800	1805	1880	1805.20	512	1842.60	699	1879.80	885
PCS 1900	1930	1990	1930.20	512	1960.00	661	1989.80	810

The transmit band spectrum is measured in several frequency segments using resolution bandwidths as specified by the standard (see the list below).

Frequency Offset	Resolution Bandwidth
≥ 1.8 MHz and < 6 MHz and inside Tx band	30 kHz
≥ 6 MHz and inside Tx band	100 kHz

The mean transmit power is measured first using the “power-above-threshold” method and the threshold is set to -20 dB (see the Transmit Power measurement for detail), and then used as a reference for the measurement limit lines if limits are used. The spectrums, which are below or above the carrier frequency and within the transmit band, are measured.

For each spectrum segment, the measurement looks for the spectrum peak closest to the limit and saves the data. The peak of all segments is reported as the `Worst Spur`. The amplitude difference from the peak to the limit line (Δ from Limit), and from the peak to the mean transmit power (Δ from Carrier) are displayed. The frequency difference from the peak to the carrier frequency (Offset Freq) is also displayed. If the peak goes above the limit line, the display will indicate `FAIL`. If Marker is on, the active marker is placed at the peak of the displayed segment.

Making the Measurement

NOTE

The factory default settings provide a measurement that complies with pre-established standards, for example GSM. For special requirements, you may need to change some of the settings. To return all parameters for the current measurement to their default settings press **Meas Setup, More (1 of 2), Restore Meas Defaults** at any time.

Select the desired transmit band, (P-GSM, E-GSM, R-GSM, DCS 1800, or PCS 1900), as described in the section [“Changing the Mode Setup” on page 36](#). Select the desired ARFCN and center frequency as described in the section [“Changing the Frequency Channel” on page 41](#).

Press **Measure, More (1 of 2), EDGE Tx Band Spur** to immediately make the EDGE Tx Band Spur the active measurement.

To change any of the measurement parameters from the factory default values, refer to the [“Changing the Measurement Setup”](#) section for this measurement.

See the end of the “Setting up the Mode” chapter for a menu map of the keys for the EDGE Tx Band Spur measurement.

Results

EDGE Tx Band Spur Result - Upper Adj Segment

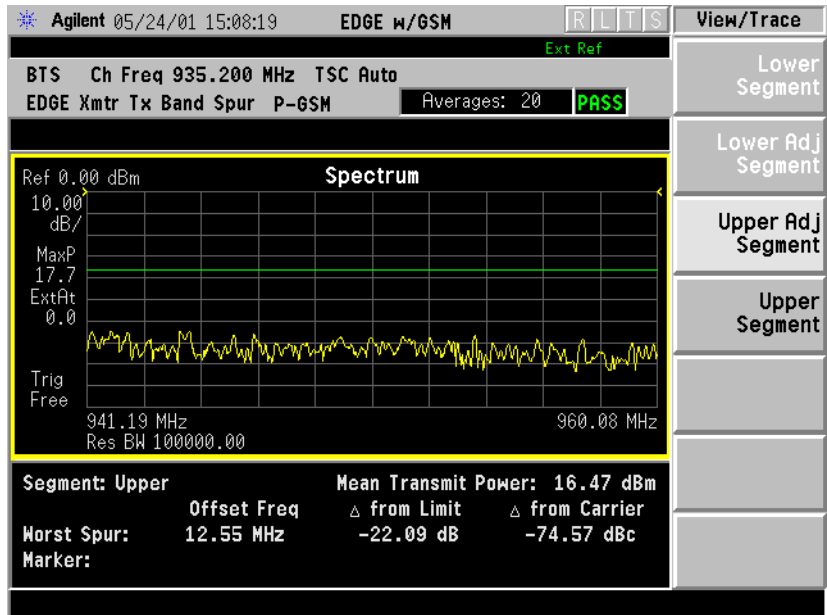

Changing the Measurement Setup

Table 3-9

EDGE Tx Band Spur Measurement Defaults

Measurement Parameter	Factory Default Condition
Avg Number	30 On
Avg Mode	Repeat
Avg Type	Maximum
Meas Type	Full
Limit	-36 dBm

Make sure the EDGE Tx Band Spur measurement is selected under the **Measure** menu. The **Meas Setup** key will access a menu which allows you to modify the averaging for this measurement. The following Tx Band Spur measurement parameters can be modified:

Meas Type - select the measurement type from the following selections:

Full - In Continuous Measure, the instrument repeatedly performs a full search of all segments.

Examine- In Continuous Measure, after doing one full search across all segments, the instrument parks on the worst segment and continuously updates that segment.

Limit - set the absolute or relative limit. The limit range is from -200 dBm to 100 dBm.

dBm - Absolute limit

dBc - Relative to Mean Transmit Power.

Changing the View

The **View/Trace** key will allow you to further examine the desired spectrum segment. See [page 144](#). Each of these choices selects a different part of the frequency spectrum for viewing:

Lower Segment	lower Tx band edge to -6 MHz offset from the channel frequency
Lower Adj Segment	-6 MHz to -1.8 MHz offset from the channel frequency
Upper Adj Segment	+1.8 MHz to +6 MHz offset from the channel frequency
Upper Segment	+6 MHz offset from the channel frequency to the upper Tx band edge

Troubleshooting Hints

Almost any fault in the transmitter circuits can manifest itself in spurious results of one kind or another. Make sure the transmit band is correctly selected and the frequency is either the **Bottom, Middle, or Top** channel. The “Unexpected carrier frequency (BMT only)” message usually indicates the transmit band and/or carrier frequency is not correct. The “ADC overload -- unexpected carrier frequency” message usually indicates the selected channel frequency does not match the carrier frequency of the signal.

Making the Spectrum (Frequency Domain) Measurement

Purpose

The spectrum measurement provides spectrum analysis capability for the instrument. The control of the measurement was designed to be familiar to those who are accustomed to using swept spectrum analyzers.

This measurement is FFT (Fast Fourier Transform) based. The FFT-specific parameters are located in the **Advanced** menu. Also available under basic mode spectrum measurements is an I/Q waveform window, which shows the I and Q signal waveforms in parameters of voltage versus time. The advantage of having an I/Q view available while in the spectrum measurement is that it allows you to view complex components of the same signal without changing settings or measurements.

Measurement Method

The measurement uses digital signal processing to sample the input signal and convert it to the frequency domain. With the instrument tuned to a fixed center frequency, samples are digitized at a high rate, converted to I and Q components with DSP hardware, and then converted to the frequency domain with FFT software.

Making the Measurement

NOTE

The factory default parameters provide a good starting point. You may want to change some of the settings. Press **Meas Setup, More (1 of 2), Restore Meas Defaults** at any time to return all parameters for the current measurement to their default settings.

Press **Measure, Spectrum (Freq Domain)** to immediately make a spectrum measurement.

To change any of the measurement parameters from the factory default values, refer to the “Changing the Measurement Setup” section for this measurement.

Results

A display with both a **Spectrum** window and an **I/Q Waveform** window will appear when you activate the spectrum measurement. Use the **Next Window** key to select a window, and the **Zoom** key to enlarge a window.

Figure 3-10 Spectrum Measurement - Spectrum and I/Q Waveform View

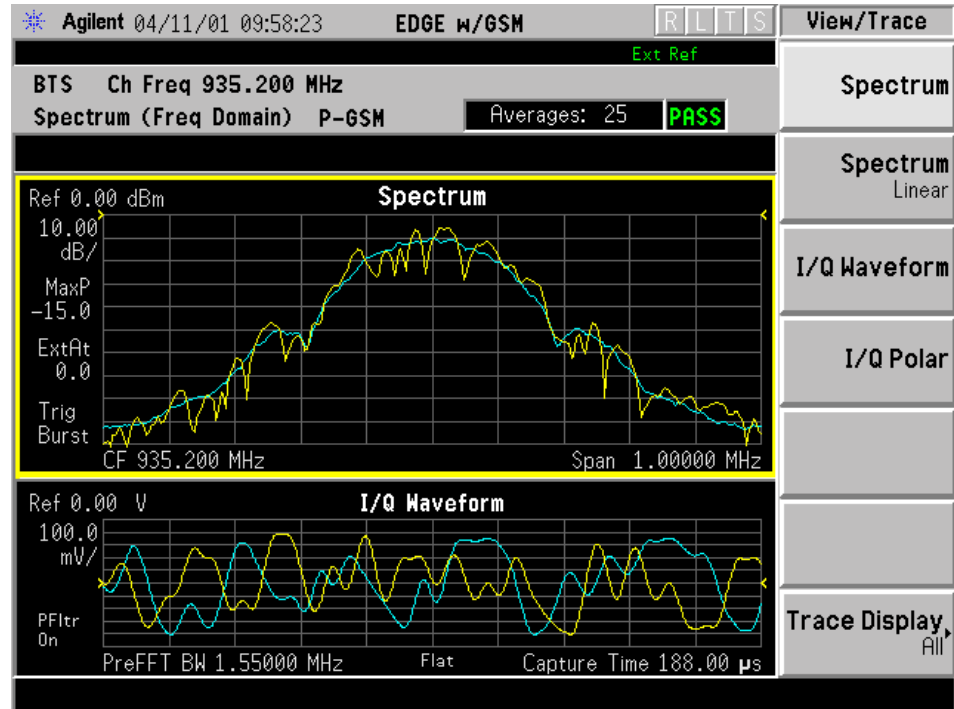

Changing the Measurement Setup

The following table shows the factory default settings for spectrum (frequency domain) measurements.

Table 3-28 Spectrum (Freq Domain) Measurement Defaults

Measurement Parameter	Factory Default Condition
View/Trace	Spectrum
Trace Display	All
Res BW	20.0000 kHz; Auto
Averaging:	
Avg Number	25; On
Avg Mode	Exp
Avg Type	Log-Pwr Avg (Video)
Trig Source	Free Run (Immediate)RF Burst (Wideband)
Spectrum View:	
Spectrum Window:	
SPAN	1.00000 MHz
AMPLITUDE Y Scale - Scale/Div	10.00 dB

Table 3-28 Spectrum (Freq Domain) Measurement Defaults

Measurement Parameter	Factory Default Condition
I/Q Waveform Window: Capture Time AMPLITUDE Y Scale - Scale/Div	188.00 μ s 100.0 mV
Advanced	
Pre-ADC BPF	On
Pre-FFT Filter	Flat
Pre-FFT BW	1.55000 MHz; Auto
FFT Window	Flat Top (High AmptdAcc)
FFT Size:	
Length Control	Auto
Min Points/RBW	3.100000
Window Length	706
FFT Length	1024
ADC Range	Auto Peak
Data Packing	Auto
ADC Dither	Auto
Decimation	0; Auto
IF Flatness	On

NOTE Parameters under the **Advanced** key seldom need to be changed. Any changes from the default advanced values may result in invalid measurement data.

Make sure the **Spectrum (Freq Domain)** measurement is selected under the **Measure** menu. Press the **Meas Setup** key to access a menu which allows you to modify the averaging and trigger source for this measurement as described in the “[Measurement Setup](#)” section.

In addition, the following parameters can be modified according to your measurement requirements:

- **Span** - Allows you to modify the frequency span. The range is 10.000 Hz to 10.000 MHz with 1 Hz resolution, depending on the **Res BW** setting. Changing the span causes the resolution bandwidth to change automatically, and will affect data acquisition time.
- **Res BW** - Allows you to set the resolution bandwidth for the FFT, and to toggle its mode between **Auto** and **Man** (manual). If set to **Auto**, the resolution bandwidth is set to **Span/50** (2% of the span). If set to **Man**, you can enter a value ranging from 100.0 mHz to 3.00000 MHz. A narrower bandwidth will result in a longer data acquisition time.

- **Advanced** - Allows you to access the menu to change the following parameters. The FFT advanced features should be used only if you are familiar with their operation. Changes from the default values may result in invalid data.
 - **Pre-ADC BPF** - Allows you to toggle the pre-ADC bandpass filter function between **On** and **Off**. The pre-ADC bandpass filter is useful for rejecting nearby signals, so that sensitivity within the span range can be improved by increasing the ADC range gain.
 - **Pre-FFT Fitr** - Allows you to toggle the pre-FFT filter between **Flat** (flat top) and **Gaussian**. The pre-FFT filter defaults to a flat top filter which has better amplitude accuracy. The Gaussian filter has better pulse response.
 - **Pre-FFT BW** - Allows you to toggle the pre-FFT bandwidth function between **Auto** and **Man** (manual). The pre-FFT bandwidth filter can be set between 1 Hz and 10 MHz. If set to **Auto**, this pre-FFT bandwidth is nominally 50% wider than the span. This bandwidth determines the ADC sampling rate.
 - **FFT Window** - Allows you to access the following selection menu. Unless you are familiar with FFT windows, use the flat top filter (the default filter).
 - Flat Top** - Selects this filter for best amplitude accuracy by reducing scalloping error.
 - Uniform** - Select this filter to have no window active by using the uniform setting.
 - Hanning** - Press this key to activate the Hanning filter.
 - Hamming** - Press this key to activate the Hamming filter.
 - Gaussian** - Press this key to activate the Gaussian filter with the roll-off factor (alpha) of 3.5.
 - Blackman** - Press this key to activate the Blackman filter.
 - Blackman-Harris** - Press this key to activate the Blackman-Harris filter.
 - K-B 70 dB, 90 dB, 110dB (Kaiser-Bessel)** - Select one of the Kaiser-Bessel filters with sidelobes at -70, -90, or -110 dBc.
 - **FFT Size** - Allows you to access the menu to change the following parameters:
 - Length Ctrl** - Allows you to toggle the FFT and window length setting function between **Auto** and **Man** (manual).
 - Min Pts in RBW** - Allows you to set the minimum number of data points that will be used inside the resolution bandwidth. The range is 0.10 to 100.00 points with 0.01 resolution. This key is grayed out if **Length Ctrl** is set to **Man**.

- Window Length** - Allows you to enter the FFT window length in the number of capture samples, ranging from 8 to 1048576. This length represents the actual quantity of I/Q samples that are captured for processing by the FFT (“Capture Time” is the associated parameter shown on the screen). This key is grayed out if **Length Control** is set to **Auto**.
- FFT Length** - Allows you to enter the FFT length in the number of captured samples, ranging from 8 to 1048576. The FFT length setting is automatically limited so that it is equal to or greater than the FFT window length setting. Any amount greater than the window length is implemented by zero-padding. This key is grayed out if **Length Control** is set to **Auto**.
- **ADC Range** - Allows you to access the menu to define one of the ADC ranging functions:
 - Auto** - Select this to set the ADC range automatically. For most FFT spectrum measurements, the auto feature should not be selected. An exception is when measuring a signal which is “bursty”, in which case auto can maximize the time domain dynamic range, if FFT results are less important to you than time domain results.
 - Auto Peak** - Select this to set the ADC range automatically to the peak signal level. Auto peak is a compromise that works well for both CW and burst signals.
 - AutoPeakLock** - Select this to hold the ADC range automatically at the peak signal level. Auto peak lock is more stable than auto peak for CW signals, but should not be used for “bursty” signals.
 - Manual** - Allows you to access the selection menu of values to set the ADC range level. Also note that manual ranging is best for CW signals.
- **Data Packing** - Allows you to select **Auto** (the default) or the **Short (16 bit)**, **Medium (24 bit)** and **Long (32 bit)** methods of data packing. The short, medium, and long methods are not compatible with all settings and should not be used unless you are familiar with data packing methods. **Auto** is the preferred choice.
 - Auto** - The data packing value most appropriate for current instrument settings is selected automatically.
 - Short (16 bit)** - Select this to pack data every 16 bits.
 - Medium (24 bit)** - Select this to pack data every 24 bits.
 - Long (32 bit)** - Select this to pack data every 32 bits.
- **ADC Dither** - Allows you to toggle the ADC dither function between **Auto**, **On**, and **Off**. When set to **Auto** (the default), the ADC dither

function will be activated when a narrow bandwidth is being measured, and deactivated when a wide bandwidth is being measured. “ADC dither” refers to the introduction of noise to the digitized steps of the analog-to-digital converter; the result is an improvement in amplitude accuracy. Use of the ADC dither, however, reduces dynamic range by approximately 3 dB.

- **Decimation** - Allows you to toggle the decimation function between **Auto** and **Man**, and to set the decimation value. **Auto** is the preferred setting, and the only setting that guarantees alias-free FFT spectrum measurements. If you are familiar with the decimation feature, you can change the decimation value by setting to **Man**, but be aware that aliasing can result in higher values. Decimation numbers 1 to 4 describe the factor by which the number of points are reduced. The default setting is 1, which results in no data point reduction.
- **IF Flatness** - Allows you to toggle the IF flatness function between **On** and **Off**. If set to **On** (the default), the IF flatness feature causes background amplitude corrections to be performed on the FFT spectrum. The **Off** setting is used for adjustment and troubleshooting of the test instrument.

Changing the View

The **View/Trace** key allows you to select the desired view of the measurement from the following. You can use the **Next Window** key to move between the multiple windows (if any) and make it full size by **Zoom**.

- **Spectrum** - Provides a combination view of the spectrum graph in parameters of power versus frequency with the semi-log graticules, and the I/Q waveform graph in the parameters of voltage and time. Changes to frequency span or power will sometimes affect data acquisition.

Changing the Display

The **Span** key under the **Meas Setup** menu controls the horizontal span of the `SpectrumSpectrum` Linear window. If the **SPAN X Scale** key is pressed, this **Span** key is activated, while the **AMPLITUDE Y Scale** key allows you to access the menus to modify the vertical parameters depending on the selected windows.

Selecting Displayed Traces

The **View/Trace** key allows you to access the **Trace Display** key to reveal the trace selection menu. The currently selected trace type is shown on the **Trace Display** key.

- **All** - Allows you to view both the current trace and the average trace.

- **Average** - Allows you to view only the average trace (in blue color).
- **Current** - Allows you to view only the trace (in yellow color) for the latest data acquisition.

Using the Markers

The **Marker** front-panel key accesses the menu to configure the markers. If you want to use the marker function in the I waveform window, press **View/Trace, I and Q Waveform, Marker, Trace, I Waveform**.

- **Select 1 2 3 4** - Allows you to activate up to four markers with the corresponding numbers, respectively. The selected number is underlined and its function is defined by pressing the **Function** key. The default is 1.
- **Normal** - Allows you to activate the selected marker to read the frequency and amplitude of the marker position on the spectrum trace. Marker position is controlled by the **RPG** knob.
- **Delta** - Allows you to read the differences in frequencies and amplitudes between the selected marker and the next.
- **Function Off** - Allows you to define the selected marker function to be **Band Power, Noise, or Off**. The default is **Off**. If set to **Band Power**, you need to select **Delta**.
- **Trace Spectrum** - Allows you to place the selected marker on the **Spectrum, Spectrum Avg, or I/Q Waveform** traces. The default is **Spectrum**.
- **Off** - Allows you to turn off the selected marker.
- **Shape Diamond** - Allows you to access the menu to define the selected marker shape to be **Diamond, Line, Square, or Cross**. The default shape is **Diamond**.
- **Marker All Off** - Allows you to turn off all of the markers.

The front panel **Search** key performs a peak search when pressed. A marker will automatically be activated at the highest peak.

Measuring Band Power

A band power measurement using the markers calculates the average power between two adjustable markers. To make a band power measurement:

1. Press the **Marker** key.
2. Press **Trace, Spectrum** to activate a marker on the instantaneous spectrum signal.
3. Press the **Spectrum Avg** key to activate a marker on the average spectrum trace.
4. Press **Function, Band Power**.
5. Two marker lines are activated at the extreme left side of the horizontal scale. Press **Normal** and move marker 1 to the desired place by rotating the **RPG** knob.
6. Press **Delta** to bring marker 2 to the same place as marker 1.
7. Move marker 1 to the other desired position by rotating the **RPG** knob. Band power measures the average power between the two markers.
8. When the band power markers are active, the results are shown in the results window as `Mean Pwr (Between Mks)`. When the band power function is off the results window reads `Mean Pwr (Entire Trace)`.

Troubleshooting Hints

Changes made by the user to advanced spectrum settings, particularly to ADC range settings, can inadvertently result in spectrum measurements that are invalid and cause error messages to appear. Care needs to be taken when using advanced features.

Making the Waveform (Time Domain) Measurement

Purpose

The waveform measurement is a generic measurement for viewing the input signal waveforms in the time domain. This measurement is how the instrument performs the zero span functionality found in traditional spectrum analyzers.

Basic mode waveform measurement data may be displayed using either a Signal Envelope window, or an I/Q window, which shows the I and Q signal waveforms in parameters of voltage versus time. The advantage of having an I/Q view available while in the waveform measurement is that it allows you to view complex components of the same signal without changing settings or measurements.

The waveform measurement can be used to perform many general purpose power measurements in the time domain with a high degree of accuracy.

Measurement Method

The instrument makes repeated power measurements at a set frequency, similar to the way a swept-tuned spectrum analyzer makes zero span measurements. The input analog signal is converted to a digital signal, which then is processed into a representation of a waveform measurement. The measurement relies on a high rates of sampling to create an accurate representation of a time domain signal.

Making the Measurement

NOTE

The factory default parameters provide a good starting point. You may want to change some of the settings. Press **Meas Setup, More (1 of 2), Restore Meas Defaults** at any time to return all parameters for the current measurement to their default settings.

Press **MEASURE, Waveform (Time Domain)** to immediately make a waveform (time domain) measurement.

To change any of the measurement parameters from the factory default values, refer to the “Changing the Measurement Setup” section for this measurement.

Results

The next figure shows an example of a Signal Envelope result for the waveform (time domain) measurements in the graph window. The measured values for the mean power and peak-to-mean power are shown in the text window.

Figure 3-11 Waveform Measurement - Signal Envelope View

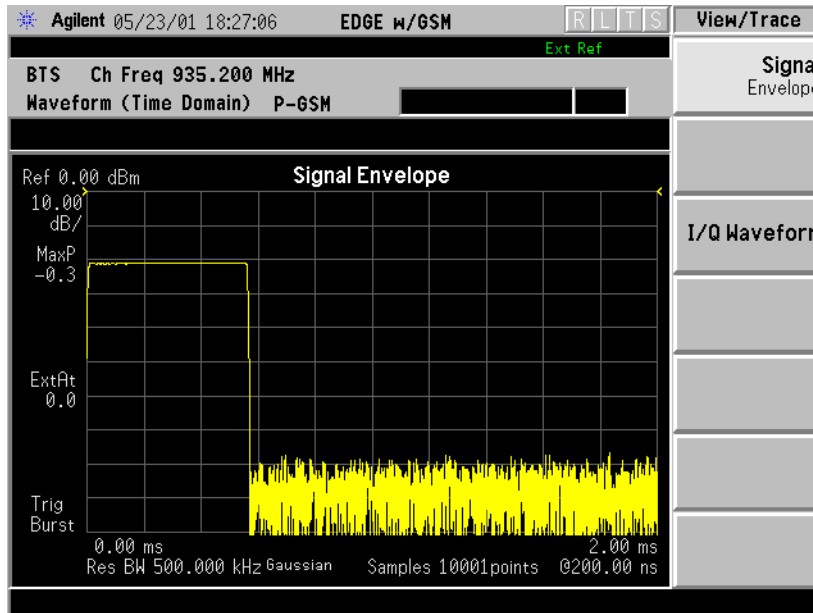
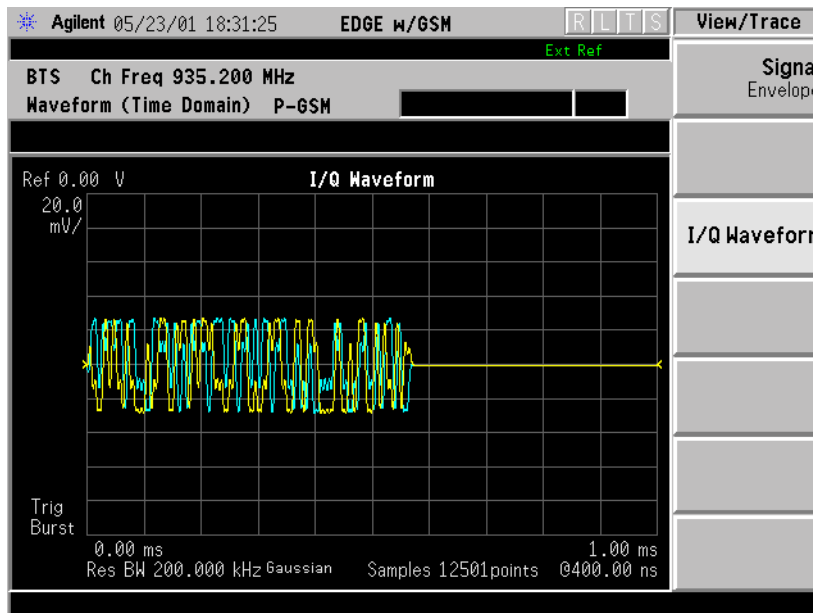

Figure 3-29 Waveform Measurement - I/Q Waveform View



Changing the Measurement Setup

This table shows the factory default settings for waveform (time domain) measurements.

Table 3-30 Waveform (Time Domain) Measurement Defaults

Measurement Parameter	Factory Default Condition
View/Trace	RF Envelope
Sweep Time	2.000 ms
Res BW	100.000 kHz500.000 kHz
Averaging:	
Avg Number	10; Off
Avg Mode	Exp
Avg Type	Pwr Avg (RMS)
Trig Source	Free Run (Immediate)RF Burst
Signal Envelope View:	
SPAN X Scale - Scale/Div	200.0 μ s
AMPLITUDE Y Scale - Scale/Div	10.00 dB
I/Q Waveform View:	
SPAN X Scale -Scale/Div	200.0 μ s
AMPLITUDE Y Scale - Scale/Div	100.0 mV
Advanced	
Pre-ADC BPF	Off
RBW Filter	Gaussian
ADC Range	Auto
Data Packing	Auto
ADC Dither	Off
Decimation	Off

NOTE Parameters that are under the **Advanced** key seldom need to be changed. Any changes from the default values may result in invalid measurement data.

Make sure the **Waveform (Time Domain)** measurement is selected under the **MEASURE** menu. Press the **Meas Setup** key to access a menu which allows you to modify the averaging, and trigger source for this measurement (as described in the “Measurement Setup” section).

In addition, the following parameters can be modified:

- **Sweep Time** - Allows you to specify the measurement acquisition time which is used as the length of the time capture record. The range is 1.0 μ s and 100.0 s, depending upon the resolution bandwidth setting and the available internal memory size for acquisition points.
- **Res BW** - Allows you to set the measurement resolution bandwidth. The range is 10 Hz to 7.5 MHz. A larger bandwidth results in a larger number of acquisition points and reduces the maximum value allowed for the sweep time.
- **Advanced** - Allows you to access the menu to change the following parameters. Changes from the default values may result in invalid data.
 - **Pre-ADC BPF** - Allows you to toggle the pre-ADC bandpass filter function between **On** or **Off**. The default setting is **Off**. The pre-ADC bandpass filter is useful for rejecting nearby signals, so that sensitivity within the span range can be improved by increasing the ADC range gain.
 - **RBW Filter** - Allows you toggle the resolution bandwidth filter selection between **Flat** and **Gaussian**. If set to **Gaussian**, the filter provides more even time-domain response, particularly for “bursts”. If set to **Flat**, the filter provides a flatter bandwidth but is less accurate for “pulse responses”. A flat top filter also requires less memory and allows longer data acquisition times. For most waveform applications, the Gaussian filter is recommended.
 - **ADC Range** - Allows you to access the menu to select one of the ADC ranging functions:
 - Auto** - Select this to cause the instrument to automatically adjust the signal range for optimal measurement results.
 - AutoPeak** - Select this to cause the instrument to continuously seek the highest peak signal.
 - AutoPeakLock** - Select this to cause the instrument to adjust the range for the highest peak signal it identifies, and retains the range settings determined by that peak signal, even when the peak signal is no longer present.
 - Manual** - Allows you to access the selection menu of values, -6 dB through +24 dB, to set the ADC range level. Also note that manual ranging is best for CW signals.
 - **Data Packing** - Allows you to access the selection menu of data

packing methods. The short, medium, and long methods are not compatible with all settings and should not be used unless you are familiar with data packing methods. **Auto** is the preferred choice.

- Auto** - The data packing value most appropriate for current instrument settings is selected automatically.
 - Short (16 bit)** - Select this to pack data every 16 bits.
 - Medium (24 bit)** - Select this to pack data every 24 bits.
 - Long (32 bit)** - Select this to pack data every 32 bits.
- **ADC Dither** - Allows you to toggle the ADC dither function between **On** and **Off**. The default setting is **Off**. If set to **On**, the ADC dither refers to the introduction of noise to the digitized steps of the analog-to-digital converter, and results in better amplitude linearity and resolution in low level signals. However, it also results in reduced dynamic range by approximately 3 dB.
- **Decimation** - Allows you to toggle the decimation function between **On** and **Off**, and to set the decimation value. Decimation allows longer acquisition times for a given bandwidth by eliminating data points. Long time captures can be limited by the instrument data acquisition memory. Decimation numbers 1 to 4 describe the factor by which the number of points are reduced. The default setting is 1, which results in no data point reduction.

Changing the View

The **View/Trace** key allows you to access the selection menu for the desired measurement view. You can use the **Next Window** key to move between the multiple windows (if any) and make it full size by **Zoom**.

Windows Available for Waveform Measurements

The following views are available to display measurement data, and are accessed by pressing the **View/Trace** key:

- **Signal Envelope** - Provides a combination view of the waveform graph in parameters of power versus time with the semi-log graticules, and the measurement results for Mean Pwr (Entire Trace), Pk-to-Mean, Current Data for Max Pt and Min Pt are shown in the text window, as of the figure in the “Result” section. Changes to sweep time or resolution bandwidth will sometimes affect data acquisition.
- **I/Q Waveform** - Provides a view of the I/Q waveform graph in parameters of voltage versus time in the linear graticules. Changes to sweep time or resolution bandwidth will sometimes affect data acquisition.

Changing the Display

The **Sweep Time** key under the **Meas Setup** menu controls the horizontal time span for this measurement, while the **SPAN X Scale** key allows you to access the menu to modify the horizontal parameters common to the rectangular windows for this measurement:

- **Scale/Div** - Allows you to set the horizontal scale by changing a time value per division. The range is 1.0 ns to 1.000 s per division with 0.01 ns resolution. The default setting is 200.0 μ s per division. However, since the **Scale Coupling** default is **On**, this value is automatically determined by the measurement result. When you set a value manually, **Scale Coupling** automatically changes to **Off**.
- **Ref Value** - Allows you to set the reference value ranging from -1.0 to 10.0 s. The default setting is 0.00 s. However, since the **Scale Coupling** default is **On**, this value is automatically determined by the measurement results. When you set a value manually, **Scale Coupling** automatically changes to **Off**.
- **Ref Position** - Allows you to set the reference position to either **Left**, **Ctr** (center) or **Right**. The default setting is **Left**.
- **Scale Coupling** - Allows you to toggle the scale coupling function between **On** and **Off**. The default setting is **On**. Upon pressing the **Restart** front-panel key or **Restart** softkey under the **Meas Control** menu, the scale coupling function automatically determines the scale per division and reference values based on the measurement results. When you set a value to either **Scale/Div** or **Ref Value** manually, **Scale Coupling** automatically changes to **Off**.

If the **Signal Envelope** window is active in the **Signal Envelope** view, the **AMPLITUDE Y Scale** key accesses the menu to modify the following parameters:

- **Scale/Div** - Allows you to set the vertical scale by changing an amplitude value per division. The range is 0.10 to 20.00 dB per division with 0.01 dB resolution. The default setting is 10.00 dB per division. However, since the **Scale Coupling** default is **On**, this value is automatically determined by the measurement result. When you set a value manually, **Scale Coupling** automatically changes to **Off**.
- **Ref Value** - Allows you to set the reference value ranging from -250.00 to 250.00 dBm. The default setting is 0.00 dBm. However, since the **Scale Coupling** default is **On**, this value is automatically determined by the measurement results. When you set a value manually, **Scale Coupling** automatically changes to **Off**.
- **Ref Position** - Allows you to set the reference position to either **Top**, **Ctr** (center) or **Bot** (bottom). The default setting is **Top**.
- **Scale Coupling** - Allows you to toggle the scale coupling function between **On** and **Off**. The default setting is **On**. Upon pressing the

Restart front-panel key or **Restart** softkey under the **Meas Control** menu, the scale coupling function automatically determines the scale per division and reference values based on the measurement results. When you set a value to either **Scale/Div** or **Ref Value** manually, **Scale Coupling** automatically changes to **Off**.

If the **I/Q Waveform** window is active in the **I/Q Waveform** view, the **AMPLITUDE Y Scale** key accesses the menu to modify the following parameters:

- **Scale/Div** - Allows you to set the vertical scale by changing an amplitude value per division. The range is 1.00 nV to 20.00 V per division. The default setting is 100.0 mV. However, since the **Scale Coupling** default is **On**, this value is automatically determined by the measurement result. When you set a value manually, **Scale Coupling** automatically changes to **Off**.
- **Ref Value** - Allows you to set the reference value ranging from -250.00 to 250.00 V. The default setting is 0.00 V. However, since the **Scale Coupling** default is **On**, this value is automatically determined by the measurement results. When you set a value manually, **Scale Coupling** automatically changes to **Off**.
- **Ref Position** - Allows you to set the reference position to either **Top**, **Ctr** (center) or **Bot** (bottom). The default setting is **Ctr**.
- **Scale Coupling** - Allows you to toggle the scale coupling function between **On** and **Off**. The default setting is **On**. Upon pressing the **Restart** front-panel key or **Restart** softkey under the **Meas Control** menu, the scale coupling function automatically determines the scale per division and reference values based on the measurement results. When you set a value to either **Scale/Div** or **Ref Value** manually, **Scale Coupling** automatically changes to **Off**.

The **Display** key is not available for this measurement.

Using the Markers

The **Marker** front-panel key accesses the menu to configure the markers.

- **Select 1 2 3 4** - Allows you to activate up to four markers with the corresponding numbers, respectively. The selected number is underlined and its function is defined by pressing the **Function** key. The default is 1.
- **Normal** - Allows you to activate the selected marker to read the time position and amplitude of the marker on the RF envelope trace. Marker position is controlled by the **RPG** knob.
- **Delta** - Allows you to read the differences in time positions and amplitudes between the selected marker and the next.
- **Function Off** - Allows you to define the selected marker function to be

Band Power, Noise, or Off. The default is **Off**. If set to **Band Power**, you need to select **Delta**.

- **Trace** - Allows you to place the selected marker on **Signal Envelope** or **I/Q Waveform** trace.
- **Off** - Allows you to turn off the selected marker.
- **Shape Diamond** - Allows you to access the menu to define the selected marker shape to be **Diamond, Line, Square, or Cross**. The default shape is **Diamond**.
- **Marker All Off** - Allows you to turn off all of the markers.

The front panel **Search** key performs a peak search when pressed. A marker will automatically be activated at the highest peak.

NOTE

In the Waveform measurement, the **Mean Pwr (Entire Trace)** value plus the **Pk-to-Mean** value will sum to equal the current **Max Pt.** value as shown in the data window below the RF Envelope display. If you do a marker peak search (**Search**) with averaging turned off, the marker will find the same maximum point. However, if you turn averaging on, the **Pk-to-Mean** value will use the highest peak found for any acquisition during averaging, while the marker peak will look for the peak of the display, which is the result of n-averages. This will usually result in differing values for the maximum point.

Troubleshooting Hints

Changes made to advanced waveform settings can inadvertently result in measurements that are invalid and cause error messages to appear. Care needs to be taken when using advanced features, as some settings may incorrectly appear to provide a valid result. Use the **Meas Setup, More, Restore Meas Defaults** function to return the measurement settings to a known state, and then vary settings only as necessary.

SCPI Command Subsystems

- “CALCulate Subsystem” on page 165
- “CONFigure Subsystem” on page 187
- “DISPlay Subsystem” on page 188
- “FETCh Subsystem” on page 197
- “FORMat Subsystem” on page 198
- “INITiate Subsystem” on page 200
- “INSTrument Subsystem” on page 203
- “MEASure Group of Commands” on page 206
- “READ Subsystem” on page 236
- “SENSe Subsystem” on page 237
- “TRIGger Subsystem” on page 333

CALCulate Subsystem

This subsystem is used to perform post-acquisition data processing. In effect, the collection of new data triggers the CALCulate subsystem. In this instrument, the primary functions in this subsystem are markers and limits.

The SCPI default for data output format is ASCII. The format can be changed to binary with FORMat:DATA which transports faster over the bus.

Test Current Results Against all Limits

`:CALCulate:CLIMits:FAIL?`

Queries the status of the current measurement limit testing. It returns a 0 if the measured results pass when compared with the current limits. It returns a 1 if the measured results fail any limit tests.

Data Query

`:CALCulate:DATA[n]?`

Returns the designated measurement data for the currently selected measurement and sub-opcode.

n = any valid sub-opcode for the current measurement. See the [“MEASure Group of Commands” on page 206](#) for information on the data that can be returned for each measurement.

For sub-opcodes that return trace data use the `:CALCulate:DATA[n]:COMPRESS?` command below.

Calculate/Compress Trace Data Query

```
:CALCulate:DATA<n>:COMPRESS?  
BLOCK|CFIT|MAXimum|MEAN|MINimum|RMS|SAMPLE|SDEVIation  
[,<soffset>[,<length>[,<roffset>[,<rlimit>]]]]
```

Returns compressed data for the specified trace data. The data is returned in the same units as the original trace and only works with the currently selected measurement. The command is used with a sub-opcode *<n>* since measurements usually return several types of trace data. See the following table for the sub-opcodes for the trace data names that are available in each measurement. For sub-opcodes that return scalar data use the :CALCulate:DATA[n]? command above.

This command is used to compress or decimate a long trace to extract and return only the desired data. A typical example would be to acquire N frames of GSM data and return the mean power of the first burst in each frame. The command can also be used to identify the best curve fit for the data.

BLOCK or block data - returns all the data points from the region of the trace data that you specify. For example, it could be used to return the data points of an input signal over several timeslots, excluding the portions of the trace data that you do not want.

CFIT or curve fit - applies curve fitting routines to the data. *<soffset>* and *<length>* are required to define the data that you want. *<roffset>* is an optional parameter for the desired order of the curve equation. The query will return the following values: the x-offset (in seconds) and the curve coefficients ((order + 1) values).

MAX, **MEAN**, **MIN**, **RMS**, **SAMP**, and **SDEV** return one data value for each specified region (or *<length>*) of trace data, for as many regions as possible until you run out of trace data (using *<roffset>* to specify regions). Or they return the number regions you specify (using *<rlimit>*) ignoring any data beyond that.

MAXimum - returns the maximum data point for the specified region(s) of trace data. For I/Q trace data, the maximum magnitude of the I/Q pairs is returned.

MEAN - returns the arithmetic mean of the data point values for the specified region(s) of trace data. For I/Q trace data, the mean of the magnitudes of the I/Q pairs is returned. Note: If the original trace data is in dB, this function returns the arithmetic mean of those log values, not log of the mean power, which is a more useful value.

MINimum - returns the minimum data point for the specified region(s) of trace data. For I/Q trace data, the minimum magnitude of the I/Q pairs is returned.

RMS - returns the arithmetic rms of the data point values for the specified region(s) of trace data. For I/Q trace data, the rms of the

magnitudes of the I/Q pairs is returned. Note: This function is very useful for I/Q trace data. However, if the original trace data is in dB, this function returns the rms of the log values which is not usually needed.

Once you have the rms value for a region of I/Q trace data, you may want to calculate the mean power. You must convert this rms I/Q value (peak volts) to power in dB.

$$10 \times \log[10 \times (\text{rms value})^2]$$

SAMPLE - returns the first data value for the specified region(s) of trace data. For I/Q trace data, the first I/Q pair is returned.

SDEViation - returns the arithmetic standard deviation for the data point values for the specified region(s) of trace data. For I/Q trace data, the standard deviation of the magnitudes of the I/Q pairs is returned.

Figure 4-1 Sample Trace Data - Constant Envelope

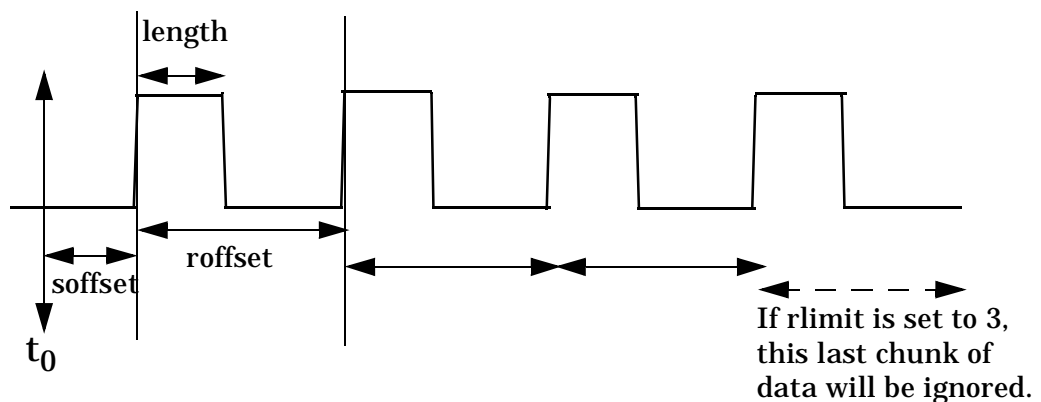
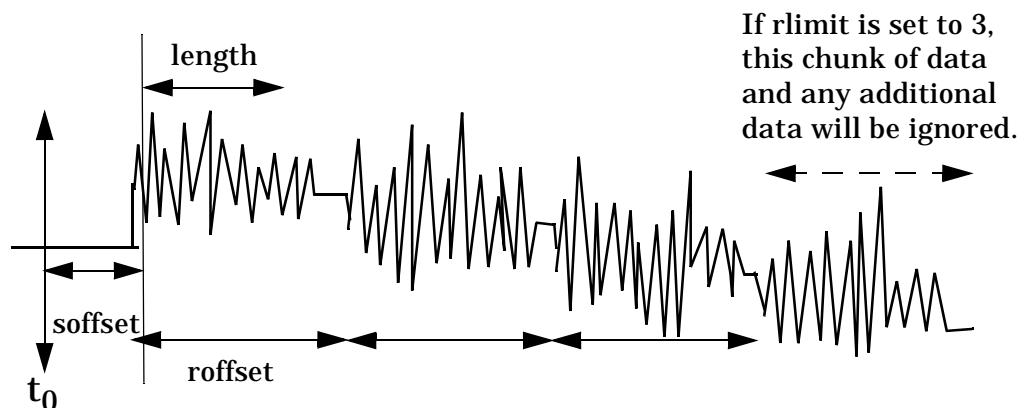

Figure 4-2 Sample Trace Data - Not Constant Envelope



<soffset> - start offset is an optional real number (in seconds). It

specifies the amount of data at the beginning of the trace that will be ignored before the decimation process starts. It is the time from the start of the trace to the point where you want to start using the data. The default value is zero.

<length> - is an optional real number (in seconds). It defines how much data will be compressed into one value. This parameter has a default value equal to the current trace length.

<roffset> - repeat offset is an optional real number (in seconds). It defines the beginning of the next field of trace elements to be compressed. This is relative to the beginning of the previous field. This parameter has a default value equal to the <length> variable.

<rlimit> - repeat limit is an optional integer. It specifies the number of data items that you want returned. It will ignore any additional items beyond that number. You can use the Start offset and the Repeat limit to pick out exactly what part of the data you want to use. The default value is all the data.

Example: To query the mean power of a set of GSM bursts:

1. Set the waveform measurement sweep time to acquire at least one burst.
2. Set the triggers such that acquisition happens at a known position relative to a burst.
3. Then query the mean burst levels using,
`CALC:DATA2:COMP? MEAN,24e-6,526e-6` (These parameter values correspond to GSM signals, where 526e-6 is the length of the burst in the slot and you just want 1 burst.)

NOTE

There is a more detailed example in the “Improving the Speed of Your Measurements” section in the PSA Series *User’s and Programmer’s Reference*. There is also a sample program in the Programming Fundamentals chapter of that book, and a copy of it is on the documentation CD-ROM.

Remarks: The optional parameters must be entered in the specified order. For example, if you want to specify <length>, you must also specify <soffset>.

This command uses the data in the format specified by FORMat:DATA, returning either binary or ASCII data.

History: Added in revision A.03.00

Measurement	Available Traces	Markers Available?
ACP - adjacent channel power (Basic, cdmaOne, cdma2000, W-CDMA, NADC, PDC modes)	no traces $(n=0)^a$ for I/Q points	no markers
CDPower - code domain power (cdmaOne mode)	POWer $(n=2)^a$ TIMing $(n=3)^a$ PHASe $(n=4)^a$ $(n=0)^a$ for I/Q points	yes
CDPower - code domain power (cdma2000, W-CDMA modes)	CDPower $(n=2)^a$ EVM $(n=5)^a$ MERRor $(n=6)^a$ PERRor $(n=7)^a$ SPOWer $(n=9)^a$ CPOWer $(n=10)^a$ $(n=0)^a$ for I/Q points	yes
CHPower - channel power (Basic, cdmaOne, cdma2000, W-CDMA modes)	SPECTrum $(n=2)^a$ $(n=0)^a$ for I/Q points	no markers
CSPur - spurs close (cdmaOne mode)	SPECTrum $(n=2)^a$ ULIMit $(n=3)^a$ $(n=0)^a$ for I/Q points	yes
EEVM - EDGE error vector magnitude (EDGE mode)	EVMerror $(n=2)^a$ MERRor $(n=3)^a$ PERRor $(n=4)^a$ $(n=0)^a$ for I/Q points	yes

Measurement	Available Traces	Markers Available?
EORFspectr - EDGE output RF spectrum (EDGE mode)	RFEMod ($n=2$) ^a RFESwitching ($n=3$) ^a SPEMod ($n=4$) ^a LIMMod ($n=5$) ^a ($n=0$) ^a for I/Q points	yes, only for a single offset yes, only for multiple offsets
EPVTime - EDGE power versus time (EDGE mode)	RFENvelope ($n=2$) ^a UMASk ($n=3$) ^a LMASk ($n=4$) ^a ($n=0$) ^a for I/Q points	yes
ETSPur - EDGE transmit band spurs (EDGE mode)	SPECtrum ($n=2$) ^a ULIMit ($n=3$) ^a ($n=0$) ^a for I/Q points	yes
EVM - error vector magnitude (NADC, PDC modes)	EVM ($n=2$) ^a MERRor ($n=3$) ^a PERRor ($n=4$) ^a ($n=0$) ^a for I/Q points	yes
EVMQpsk - QPSK error vector magnitude (cdma2000, W-CDMA modes)	EVM ($n=2$) ^a MERRor ($n=3$) ^a PERRor ($n=4$) ^a ($n=0$) ^a for I/Q points	yes
IM - intermodulation (cdma2000, W-CDMA modes)	SPECtrum ($n=2$) ^a ($n=0$) ^a for I/Q points	yes
MCPower - multi-carrier power (W-CDMA mode)	no traces ($n=0$) ^a for I/Q points	no markers
OBW - occupied bandwidth (cdmaOne, cdma2000, PDC, W-CDMA modes)	no traces ($n=0$) ^a for I/Q points	no markers

Measurement	Available Traces	Markers Available?
ORFSpectrum - output RF spectrum (GSM, EDGE mode)	RFEMod ($n=2$) ^a RFESwitching ($n=3$) ^a SPEMod ($n=4$) ^a LIMMod ($n=5$) ^a ($n=0$) ^a for I/Q points	yes, only for a single offset yes, only for multiple offsets
PFERror - phase and frequency error (GSM, EDGE mode)	PERRor ($n=2$) ^a PFERror ($n=3$) ^a RFENvelope ($n=4$) ^a ($n=0$) ^a for I/Q points	yes
PStatistic - power statistics CCDF (Basic, cdma2000, W-CDMA modes)	MEASured ($n=2$) ^a GAUSian ($n=3$) ^a REFerence ($n=4$) ^a ($n=0$) ^a for I/Q points	yes
PVTime - power versus time (GSM, EDGE modes)	RFENvelope ($n=2$) ^a UMASk ($n=3$) ^a LMASk ($n=4$) ^a ($n=0$) ^a for I/Q points	yes
RHO - modulation quality (cdmaOne, cdma2000, W-CDMA mode)	($n=0$) ^a for I/Q points EVM ($n=2$) ^a MERRor ($n=3$) ^a PERRor ($n=4$) ^a ($n=0$) ^a for I/Q points	yes
SEMask - spectrum emissions mask (cdma2000, W-CDMA mode)	SPECtrum ($n=2$) ^a ($n=0$) ^a for I/Q points	yes
TSPur - transmit band spurs (GSM, EDGE mode)	SPECtrum ($n=2$) ^a ULIMit ($n=3$) ^a ($n=0$) ^a for I/Q points	yes

Measurement	Available Traces	Markers Available?
TXPower - transmit power (GSM, EDGE mode)	RFENvelope ($n=2$) ^a IQ ($n=8$) ^a ($n=0$) ^a for I/Q points	yes
SPECtrum - (frequency domain) (all modes)	IQ ($n=3$) ^a SPECtrum ($n=4$) ^a ASPECTrum ($n=7$) ^a ($n=0$) ^a for I/Q points	yes
WAVEform - (time domain) (all modes)	RFENvelope ($n=2$) ^a (also for Signal Envelope trace) IQ ($n=5$) ^a ($n=0$) ^a for I/Q points	yes

a. The n number indicates the sub-opcode that corresponds to this trace. Detailed descriptions of the trace data can be found in the MEASure subsystem documentation by looking up the sub-opcode for the appropriate measurement.

Calculate Peaks of Trace Data

```
:CALCulate:DATA<n>:PEAKs?
<threshold>,<excursion>[ ,AMPLitude|FREQuency|TIME ]
```

Returns a list of peaks for the designated trace data n for the currently selected measurement. The peaks must meet the requirements of the peak threshold and excursion values.

The command can only be used with specific $<n>$ (sub-opcode) values, for measurement results that are trace data. See the table above for the appropriate sub-opcodes. Both real and complex traces can be searched, but complex traces are converted to magnitude in dBm. Sub-opcode $n=0$, is the raw trace data which cannot be searched for peaks. Sub-opcode $n=1$, is the scaler data which also cannot be searched for peaks.

Threshold - is the level below which trace data peaks are ignored

Excursion - To be defined as a peak, the signal must rise above the threshold by a minimum amplitude change. Excursion is measured from the lowest point above the threshold (of the rising edge of the

peak), to the highest signal point that begins the falling edge.

Amplitude - lists the peaks in order of descending amplitude, so the highest peak is listed first. This is the default peak order listing if the optional parameter is not specified.

Frequency - lists the peaks in order of occurrence, left to right across the x-axis

Time - lists the peaks in order of occurrence, left to right across the x-axis

Example: Select the spectrum measurement.

Use `CALC:DATA4:PEAK? -40,10,FREQ` to identify the peaks above -40 dBm, with excursions of at least 10 dB, in order of increasing frequency.

Query Results: Returns a list of floating-point numbers. The first value in the list is the number of peak points that follow. A peak point consists of two values: a peak amplitude followed by the its corresponding frequency (or time).

If no peaks are found the peak list will consist of only the number of peaks, (0).

The peak list is limited to 100 peaks. Peaks in excess of 100 are ignored.

Remarks: This command uses the data setting specified by the `FORMat:DATA` command and can return real 32-bit, real 64-bit, or ASCII data. The default data format is ASCII.

EDGE TX Band Spur Calculate Commands

EDGE Transmit Band Spurs—Type of Limit Testing

:CALCulate:ETSPur:LIMit:TEST ABSolute | RELative

:CALCulate:ETSPur:LIMit:TEST?

Select the limit testing to be done using either absolute (dBm) or relative power (dB) limits.

Factory Preset: Absolute

Remarks: You must be in the EDGE (w/GSM) mode to use this command. Use INSTRument:SElect to set the mode.

Front Panel

Access: Meas Setup, More, Limit

EDGE Transmit Band Spurs—Define Limits

:CALCulate:ETSPur:LIMit[:UPPer][:DATA] <power>

:CALCulate:ETSPur:LIMit[:UPPer][:DATA]?

Set the value for the test limit. This command does not accept units. Use CALCulate:ETSPur:LIMit:TEST to select the units dBm (absolute) or dB (relative).

Factory Preset: -36

Range: -200 to 100

Remarks: You must be in the EDGE (w/GSM) mode to use this command. Use INSTRument:SElect to set the mode.

Front Panel

Access: Meas Setup, More, Limit

CALCulate:MARKers Subsystem

Markers can be put on your displayed measurement data to supply information about specific points on the data. Some of the things that markers can be used to measure include: precise frequency at a point, minimum or maximum amplitude, and the difference in amplitude or frequency between two points.

When using the marker commands you must specify the measurement in the SCPI command. We recommend that you use the marker commands only on the current measurement. Many marker commands will return invalid results, when used on a measurement that is not current. (This is true for commands that do more than simply setting or querying an instrument parameter.) No error is reported for these invalid results.

You must make sure that the measurement is completed before trying to query the marker value. Using the MEASure or READ command, before the marker command, forces the measurement to complete before allowing the next command to be executed.

Each measurement has its own instrument state for marker parameters. Therefore, if you exit the measurement, the marker settings in each measurement are saved and are then recalled when you change back to that measurement.

Basic Mode - <measurement> key words

- SPECTrum - markers available
- WAVeform - markers available

cdmaOne Mode - <measurement> key words

- ACPr - no markers
- CHPower - no markers
- CDPower - markers available
- CSPur - markers available
- RHO - markers available
- SPECTrum - markers available
- WAVeform - markers available

cdma2000 Mode - <measurement> key words

- ACP - no markers
- CDPower - markers available
- CHPower - no markers
- EVMQpsk - markers available
- IM - markers available
- OBW - no markers
- PStatistic - markers available
- RHO - markers available
- SEMask - markers available

- SPECTrum - markers available
- WAVEform - markers available

GSM (with EDGE) Mode - <measurement> key words

- EEVM - markers available
- EORFspectr - markers available
- EPVTime - no markers
- ETSPur - markers available
- ORFSpectrum - markers available
- PFERror - markers available
- PVTime - no markers
- SPECTrum - markers available
- TSPur - markers available
- TXPower - no markers
- WAVEform - markers available

NADC Mode - <measurement> key words

- ACP - no markers
- EVM - markers available
- SPECTrum - markers available
- WAVEform - markers available

PDC Mode - <measurement> key words

- ACP - no markers
- EVM - markers available
- OBW - no markers
- SPECTrum - markers available
- WAVEform - markers available

W-CDMA Mode - <measurement> key words

- ACP - no markers
- CDPower - markers available
- CHPower - no markers
- EVMQpsk - markers available
- IM - markers available
- MCPower - no markers
- OBW - no markers
- PStatistic - markers available
- RHO - markers available
- SEMask - markers available
- SPECTrum - markers available
- WAVEform - markers available

Example:

Suppose you are using the Spectrum measurement in your measurement personality. To position marker 2 at the maximum peak

value of the trace that marker 2 is currently on, the command is:

:CALCulate:SPECTrum:MARKer2:MAXimum

You must make sure that the measurement is completed before trying to query the marker value. Use the MEASure or READ command before using the marker command. This forces the measurement to complete before allowing the next command to be executed.

Markers All Off on All Traces

:CALCulate:<measurement>:MARKer:AOFF

Turns off all markers on all the traces in the specified measurement.

Example: **CALC:SPEC:MARK:AOFF**

Remarks: The keyword for the current measurement must be specified in the command. (Some examples include: SPECTrum, WAVeform)

Front Panel

Access: **Marker, More, Marker All Off**

Marker Mode

**:CALCulate:<measurement>:MARKer[1] | 2 | 3 | 4:MODE
POSITION|DELTA**

:CALCulate:<measurement>:MARKer[1] | 2 | 3 | 4:MODE?

Selects the type of marker to be a normal position-type marker or a delta marker. A specific measurement may not have both types of markers. For example, several measurements only have position markers.

The marker must have already been assigned to a trace. Use

:CALCulate:<measurement>:MARKer[1] | 2 | 3 | 4:TRACe to assign a marker to a particular trace.

Example: **CALC:SPEC:MARK:MODE DELTA**

Remarks: For the delta mode only markers 1 and 2 are valid.

The keyword for the current measurement must be specified in the command. (Some examples include: SPECTrum, WAVeform)

Front Panel

Access: **Marker, Marker [Delta]**

Marker Function Result

`:CALCulate:<measurement>:MARKer[1]|2|3|4:FUNCTION:RESult?`

Queries the result of the currently active marker function. The measurement must be completed before querying the marker. A particular measurement may not have all the types of markers available.

The marker must have already been assigned to a trace. Use `:CALCulate:<measurement>:MARKer[1]|2|3|4:TRACe` to assign a marker to a particular trace.

Example: `CALC:SPEC:MARK:FUNC:RES?`

Remarks: The keyword for the current measurement must be specified in the command. (Some examples include: SPECTrum, WAVeform)

Front Panel

Access: **Marker, Marker Function**

Marker Peak (Maximum) Search

`:CALCulate:<measurement>:MARKer[1]|2|3|4:MAXimum`

Places the selected marker on the highest point on the trace that is assigned to that particular marker number.

The marker must have already been assigned to a trace. Use `:CALCulate:<measurement>:MARKer[1]|2|3|4:TRACe` to assign a marker to a particular trace.

Example: `CALC:SPEC:MARK1:MAX`

Remarks: The keyword for the current measurement must be specified in the command. (Some examples include: SPECTrum, WAVeform)

Front Panel

Access: **Search**

Marker Peak (Minimum) Search

`:CALCulate:<measurement>:MARKer[1]|2|3|4:MINimum`

Places the selected marker on the lowest point on the trace that is assigned to that particular marker number.

The marker must have already been assigned to a trace. Use `:CALCulate:<measurement>:MARKer[1]|2|3|4:TRACe` to assign a marker to a particular trace.

Example: **CALC:SPEC:MARK2 MIN**

Remarks: The keyword for the current measurement must be specified in the command. (Some examples include: SPECTrum, WAVeform)

Marker Mode

PSA Series (not for Spectrum Analysis or Phase Noise mode):

```
:CALCulate:<measurement>:MARKer[1] | 2 | 3 | 4:MODE  
POSITION|DELTA
```

ESA/PSA Series Phase Noise mode only:

```
:CALCulate:<measurement>:MARKer[1] | 2 | 3 | 4:MODE  
POSITION|DELTA|RMSDegree|RMSRadian|RFM|RMSJitter|OFF
```

```
:CALCulate:<measurement>:MARKer[1] | 2 | 3 | 4:MODE?
```

Selects the type of marker to be a normal position-type marker or a delta marker. A specific measurement may not have both types of markers. For example, several measurements only have position markers

The marker must have already been assigned to a trace. Use **:CALCulate:<measurement>:MARKer[1] | 2 | 3 | 4:TRACe** to assign a marker to a particular trace.

Example: **CALC:SPEC:MARK:MODE DELTA**

Remarks: For the delta mode only markers 1 and 2 are valid.

 The keyword for the current measurement must be specified in the command. (Some examples include: SPECTrum, WAVeform)

Front Panel

Access: **Marker, Marker [Delta]**

Marker On/Off

```
:CALCulate:<measurement>:MARKer[1] | 2 | 3 | 4[:STATe] OFF|ON|0|1
```

```
:CALCulate:<measurement>:MARKer[1] | 2 | 3 | 4[:STATe]?
```

Turns the selected marker on or off.

The marker must have already been assigned to a trace. Use **:CALCulate:<measurement>:MARKer[1] | 2 | 3 | 4:TRACe** to assign a marker to a particular trace.

Example: **CALC:SPEC:MARK2: on**

Remarks: The keyword for the current measurement must be specified in the command. (Some examples include: SPECTrum, AREFERENCE, WAVeform)

The WAVeform measurement only has two markers available.

Front Panel

Access: **Marker, Select then Marker Normal or Marker On Off**

Marker to Trace

:CALCulate:<measurement>:MARKer[1]|2|3|4:TRACe <trace_name>

:CALCulate:<measurement>:MARKer[1]|2|3|4:TRACe?

Assigns the specified marker to the designated trace. Not all types of measurement data can have markers assigned to them.

Example: With the WAVeform measurement selected, a valid command is **CALC:SPEC:MARK2:TRACE rfenvelope**.

Range: The names of valid traces are dependent upon the selected measurement. See the following table for the available trace names. The trace name assignment is independent of the marker number.

Remarks: The keyword for the current measurement must be specified in the command. (Some examples include: SPECTrum, WAVeform)

Front Panel

Access: **Marker, Marker Trace**

Measurement	Available Traces	Markers Available?
ACP - adjacent channel power (Basic, cdmaOne, cdma2000, W-CDMA, NADC, PDC modes)	no traces $(n=0)^a$ for I/Q points	no markers
CDPower - code domain power (cdmaOne mode)	POWer $(n=2)^a$ TIMing $(n=3)^a$ PHASe $(n=4)^a$ $(n=0)^a$ for I/Q points	yes

Measurement	Available Traces	Markers Available?
CDPower - code domain power (cdma2000, W-CDMA modes)	CDPower ($n=2$) ^a EVM ($n=5$) ^a MERRor ($n=6$) ^a PERRor ($n=7$) ^a SPOWer ($n=9$) ^a CPOWer ($n=10$) ^a ($n=0$) ^a for I/Q points	yes
CHPower - channel power (Basic, cdmaOne, cdma2000, W-CDMA modes)	SPECTrum ($n=2$) ^a ($n=0$) ^a for I/Q points	no markers
CSPur - spurs close (cdmaOne mode)	SPECTrum ($n=2$) ^a ULIMit ($n=3$) ^a ($n=0$) ^a for I/Q points	yes
EEVM - EDGE error vector magnitude (EDGE mode)	EVMerror ($n=2$) ^a MERRor ($n=3$) ^a PERRor ($n=4$) ^a ($n=0$) ^a for I/Q points	yes
EORFspectr - EDGE output RF spectrum (EDGE mode)	RFEMod ($n=2$) ^a RFESwitching ($n=3$) ^a SPEMod ($n=4$) ^a LIMMod ($n=5$) ^a ($n=0$) ^a for I/Q points	yes, only for a single offset yes, only for multiple offsets
EPVTime - EDGE power versus time (EDGE mode)	RFENvelope ($n=2$) ^a UMASk ($n=3$) ^a LMASk ($n=4$) ^a ($n=0$) ^a for I/Q points	yes
ETSPur - EDGE transmit band spurs (EDGE mode)	SPECTrum ($n=2$) ^a ULIMit ($n=3$) ^a ($n=0$) ^a for I/Q points	yes

Measurement	Available Traces	Markers Available?
EVM - error vector magnitude (NADC, PDC modes)	EVM ($n=2$) ^a MERRor ($n=3$) ^a PERRor ($n=4$) ^a ($n=0$) ^a for I/Q points	yes
EVMQpsk - QPSK error vector magnitude (cdma2000, W-CDMA modes)	EVM ($n=2$) ^a MERRor ($n=3$) ^a PERRor ($n=4$) ^a ($n=0$) ^a for I/Q points	yes
IM - intermodulation (cdma2000, W-CDMA modes)	SPECtrum ($n=2$) ^a ($n=0$) ^a for I/Q points	yes
MCPower - multi-carrier power (W-CDMA mode)	no traces ($n=0$) ^a for I/Q points	no markers
OBW - occupied bandwidth (cdmaOne, cdma2000, PDC, W-CDMA modes)	no traces ($n=0$) ^a for I/Q points	no markers
ORFSpectrum - output RF spectrum (GSM, EDGE mode)	RFEMod ($n=2$) ^a RFESwitching ($n=3$) ^a SPEMod ($n=4$) ^a LIMMod ($n=5$) ^a ($n=0$) ^a for I/Q points	yes, only for a single offset yes, only for multiple offsets
PFERror - phase and frequency error (GSM, EDGE mode)	PERRor ($n=2$) ^a PFERror ($n=3$) ^a RFENvelope ($n=4$) ^a ($n=0$) ^a for I/Q points	yes
PStatistic - power statistics CCDF (Basic, cdma2000, W-CDMA modes)	MEASured ($n=2$) ^a GAUSian ($n=3$) ^a REFerence ($n=4$) ^a ($n=0$) ^a for I/Q points	yes

Measurement	Available Traces	Markers Available?
PVTime - power versus time (GSM, EDGE modes)	RFENvelope ($n=2$) ^a UMASk ($n=3$) ^a LMASk ($n=4$) ^a ($n=0$) ^a for I/Q points	yes
RHO - modulation quality (cdmaOne, cdma2000, W-CDMA mode)	($n=0$) ^a for I/Q points EVM ($n=2$) ^a MERRor ($n=3$) ^a PERRor ($n=4$) ^a ($n=0$) ^a for I/Q points	yes
SEMask - spectrum emissions mask (cdma2000, W-CDMA mode)	SPECTrum ($n=2$) ^a ($n=0$) ^a for I/Q points	yes
TSPur - transmit band spurs (GSM, EDGE mode)	SPECTrum ($n=2$) ^a ULIMit ($n=3$) ^a ($n=0$) ^a for I/Q points	yes
TXPower - transmit power (GSM, EDGE mode)	RFENvelope ($n=2$) ^a IQ ($n=8$) ^a ($n=0$) ^a for I/Q points	yes
SPECTrum - (frequency domain) (all modes)	IQ ($n=3$) ^a SPECTrum ($n=4$) ^a ASPECTrum ($n=7$) ^a ($n=0$) ^a for I/Q points	yes
WAVEform - (time domain) (all modes)	RFENvelope ($n=2$) ^a (also for Signal Envelope trace) IQ ($n=5$) ^a ($n=0$) ^a for I/Q points	yes

a. The n number indicates the sub-opcode that corresponds to this trace. Detailed descriptions of the trace data can be found in the MEASure subsystem documentation by looking up the sub-opcode for the appropriate measurement.

Marker X Value

`:CALCulate:<measurement>:MARKer[1]|2|3|4:X <param>`

`:CALCulate:<measurement>:MARKer[1]|2|3|4:X?`

Position the designated marker on its assigned trace at the specified X value. The parameter value is in X-axis units (which is often frequency or time).

The marker must have already been assigned to a trace. Use `:CALCulate:<measurement>:MARKer[1]|2|3|4:TRACe` to assign a marker to a particular trace.

The query returns the current X value of the designated marker. The measurement must be completed before querying the marker.

Example: `CALC:SPEC:MARK2:X 1.2e6 Hz`

Default Unit: Matches the units of the trace on which the marker is positioned

Remarks: The keyword for the current measurement must be specified in the command. (Some examples include: SPECTrum, WAVeform)

Front Panel

Access: **Marker, <active marker>, RPG**

Marker X Position

`:CALCulate:<measurement>:MARKer[1]|2|3|4:X:POSition <integer>`

`:CALCulate:<measurement>:MARKer[1]|2|3|4:X:POSition?`

Position the designated marker on its assigned trace at the specified X position. A trace is composed of a variable number of measurement points. This number changes depending on the current measurement conditions. The current number of points must be identified before using this command to place the marker at a specific location.

The marker must have already been assigned to a trace. Use `:CALCulate:<measurement>:MARKer[1]|2|3|4:TRACe` to assign a marker to a particular trace.

The query returns the current X position for the designated marker. The measurement must be completed before querying the marker.

Example: `CALC:SPEC:MARK:X:POS 500`

Range: 0 to a maximum of (3 to 920,000)

Remarks: The keyword for the current measurement must be specified in the command. (Some examples include: SPECTrum, WAVeform)

Front Panel

Access: Marker, <active marker>, RPG

Marker Readout Y Value

`:CALCulate:<measurement>:MARKer[1]|2|3|4:Y?`

Readout the current Y value for the designated marker on its assigned trace. The value is in the Y-axis units for the trace (which is often dBm).

The marker must have already been assigned to a trace. Use `:CALCulate:<measurement>:MARKer[1]|2|3|4:TRACe` to assign a marker to a particular trace.

The measurement must be completed before querying the marker.

Example: `CALC:SPEC:MARK1:Y?`

Default Unit: Matches the units of the trace on which the marker is positioned

Remarks: The keyword for the current measurement must be specified in the command. (Some examples include: SPECTrum, WAVeform)

Transmit Band Spurious - Limits

Transmit Band Spurs—Type of Limit Testing

```
:CALCulate:TSPur:LIMit:TEST ABSolute|RELative
```

```
:CALCulate:TSPur:LIMit:TEST?
```

Select the limit testing to be done using either absolute or relative power limits.

Factory Preset: Absolute

Remarks: You must be in the GSM, EDGE(w/GSM) mode to use this command. Use INSTRUMENT:SElect to set the mode.

History: Version A.03.00 or later

Front Panel

Access: Meas Setup, Limit

Transmit Band Spurs—Define Limits

```
:CALCulate:TSPur:LIMit[:UPPer][:DATA] <power>
```

```
:CALCulate:TSPur:LIMit[:UPPer][:DATA]?
```

Set the value for the test limit. This command does not accept units. Use CALCulate:TSPur:LIMit:TEST to select the units dBm (absolute) or dB (relative).

Factory Preset: -36

Range: -200 to 100

Remarks: You must be in the GSM, EDGE (w/GSM) mode to use this command. Use INSTRUMENT:SElect to set the mode.

History: Version A.03.00 or later

Front Panel

Access: Meas Setup, Limit

CONFigure Subsystem

[VSA] [PSA] [ESA-C,G,PN] The CONFigure commands are used with several other commands to control the measurement process. The full set of commands are described in the section “[MEASure Group of Commands](#)” on page 206.

Selecting measurements with the CONFigure/FETCh/MEASure/READ commands sets the instrument state to the defaults for that measurement and to make a single measurement. Other commands are available for each measurement to allow you to change: settings, view, limits, etc. Refer to:

SENSe:<measurement>, SENSe:CHANnel, SENSe:CORRection,
 SENSe:DEFaults, SENSe:DEViation, SENSe:FREQuency,
 SENSe:PACKet, SENSe:POWer, SENSe:RADio, SENSe:SYNC
 CALCulate:<measurement>, CALCulate:CLIMits
 DISPlay:<measurement>
 TRIGger

The INITiate[:IMMediate] or INITiate:REStart commands will initiate the taking of measurement data without resetting any of the measurement settings that you have changed from their defaults.

Configure the Selected Measurement

:CONFigure:<measurement>

A CONFigure command must specify the desired measurement. It will set the instrument settings for that measurements standard defaults, but should not initiate the taking of data. The available measurements are described in the MEASure subsystem.

NOTE

If CONFigure initiates the the taking of data, the data should be ignored. Other SCPI commands can be processed immediately after sending CONFigure. You do not need to wait for the CONF command to complete this 'false' data acquisition.

Configure Query

:CONFigure?

The CONFigure query returns the name of the current measurement.

DISPlay Subsystem

The DISPlay controls the selection and presentation of textual, graphical, and TRACe information. Within a DISPlay, information may be separated into individual WINDows.

EDGE PVT - Limit Mask On/Off

```
:DISPlay:EPVTime:LIMit:MASK OFF|ON|0|1
```

```
:DISPlay:EPVTime:LIMit:MASK?
```

Turns on/off the display of the limit mask lines. It also disables the limit checking.

Factory Preset: On

Remarks: You must be in EDGE (w/GSM) to use this command.
Use INSTRument:SElect to set the mode.

Front Panel

Access: **Display**, with EPVT measurement selected

Select Display Format

```
:DISPlay:FORMat:TILE
```

Selects the viewing format that displays multiple windows of the current measurement data simultaneously. Use DISP:FORM:ZOOM to return the display to a single window.

Remarks: You must be in the Basic, cdmaOne,cdma2000, W-CDMA, EDGE (w/GSM), NADC, or PDC mode to use this command. Use INSTRument:SElect to set the mode

Front Panel

Access: **Zoom** (toggles between Tile and Zoom)

Select Display Format

```
:DISPlay:FORMat:ZOOM
```

Selects the viewing format that displays only one window of the current measurement data (the current active window). Use DISP:FORM:TILE to return the display to multiple windows.

Remarks: You must be in the Basic, cdmaOne, cdma2000, W-CDMA, EDGE (w/GSM), NADC, or PDC mode to use this command. Use INSTRUMENT:SElect to set the mode

Front Panel

Access: **Zoom** (toggles between Tile and Zoom)

PVT - Limit Mask On/Off

```
:DISPlay:PVTIme:LIMit:MASK OFF|ON|0|1
```

```
:DISPlay:PVTIme:LIMit:MASK?
```

Turns on/off the display of the limit mask lines. It also disables the limit checking.

Factory Preset: On

Remarks: You must be in GSM, EDGE (w/GSM) to use this command. Use INSTRUMENT:SElect to set the mode.

Front Panel

Access: **Display**, with PVT measurement selected

Spectrum - Y-Axis Scale/Div

```
:DISPlay:SPECTrum[n]:WINDow[m]:TRACe:Y[:SCALE]:PDIVision  
<power>
```

```
:DISPlay:SPECTrum[n]:WINDow[m]:TRACe:Y[:SCALE]:PDIVision?
```

Sets the amplitude reference level for the y-axis.

n – selects the view, the default is Spectrum.

m – selects the window within the view. The default is 1.

— n=1, m=1 Spectrum

— n=1, m=2 I/Q Waveform

— n=1, m=2 I and Q Waveform (Basic, W-CDMA, cdma2000)

— n=3, m=1 I/Q Polar (Basic, W-CDMA, cdma2000)

— n=4, m=1 Linear Spectrum (Basic, W-CDMA, cdma2000)

Factory Preset: 10 dB per division, for Spectrum

100 mV per division, for I/Q Waveform

Range: 0.1 dB to 20 dB per division, for Spectrum

1 nV to 20 V per division, for I/Q Waveform

Default Unit: 10 dB per division, for Spectrum

Remarks: May affect input attenuator setting.

You must be in Basic, cdmaOne, cdma2000, W-CDMA GSM w/EDGE, NADC, or PDC mode. Set the mode with INSTRUMENT:SElect.

Front Panel

Access: When in Spectrum measurement: **Amplitude Y Scale, Scale/Div.**

History: Added revision A.02.00

Spectrum - Y-Axis Reference Level

```
:DISPlay:SPECTrum[n]:WINDow[m]:TRACe:Y[:SCALe]:RLEVel  
<power>
```

```
:DISPlay:SPECTrum[n]:WINDow[m]:TRACe:Y[:SCALe]:RLEVel?
```

Sets the amplitude reference level for the y-axis.

n, selects the view, the default is RF envelope.

— n=1, m=1 Spectrum

— n=1, m=2 I/Q Waveform

— n=1, m=2 I and Q Waveform (Basic, W-CDMA, cdma2000)

— n=3, m=1 I/Q Polar (Basic, W-CDMA, cdma2000)

— n=4, m=1 Linear Spectrum (Basic, W-CDMA, cdma2000)

m – selects the window within the view. The default is 1.

Factory Preset: 0 dBm, for Spectrum

Range: –250 to 250 dBm, for Spectrum

Default Unit: dBm, for Spectrum

Remarks: May affect input attenuator setting.

You must be in Basic, cdmaOne, cdma2000, W-CDMA GSM w/EDGE, NADC, or PDC mode. Set the mode with INSTRUMENT:SElect.

Front Panel

Access: When in Spectrum measurement: **Amplitude Y Scale, Ref Level**

History: Added revision A.02.00

Turn a Trace Display On/Off

`:DISPlay:TRACe[n][:STATe] OFF|ON|0|1`

`:DISPlay:TRACe[n][:STATe]?`

Controls whether the specified trace is visible or not.

n is a sub-opcode that is valid for the current measurement. See the “MEASure Group of Commands” on page 206 for more information about sub-opcodes.

Factory Preset: On

Range: The valid traces and their sub-opcodes are dependent upon the selected measurement. See the following table.

The trace name assignment is independent of the window number.

Remarks: You must be in the Basic, cdmaOne, cdma2000, W-CDMA, EDGE (w/GSM), NADC, or PDC mode to use this command. Use INSTRument:SElect to set the mode

Front Panel

Access: **Display, Display Traces**

Measurement	Available Traces	Markers Available?
ACP - adjacent channel power (Basic, cdmaOne, cdma2000, W-CDMA, NADC, PDC modes)	no traces <i>(n=0)</i> ^a for I/Q points	no markers
CDPower - code domain power (cdmaOne mode)	POWer (<i>n=2</i>) ^a TIMing (<i>n=3</i>) ^a PHASe (<i>n=4</i>) ^a <i>(n=0)</i> ^a for I/Q points	yes
CDPower - code domain power (cdma2000, W-CDMA modes)	CDPower (<i>n=2</i>) ^a EVM (<i>n=5</i>) ^a MERRor (<i>n=6</i>) ^a PERRor (<i>n=7</i>) ^a SPOWer (<i>n=9</i>) ^a CPOWer (<i>n=10</i>) ^a <i>(n=0)</i> ^a for I/Q points	yes

Measurement	Available Traces	Markers Available?
CHPower - channel power (Basic, cdmaOne, cdma2000, W-CDMA modes)	SPECtrum ($n=2$) ^a ($n=0$) ^a for I/Q points	no markers
CSPur - spurs close (cdmaOne mode)	SPECtrum ($n=2$) ^a ULIMit ($n=3$) ^a ($n=0$) ^a for I/Q points	yes
EEVM - EDGE error vector magnitude (EDGE mode)	EVMerror ($n=2$) ^a MERRor ($n=3$) ^a PERRor ($n=4$) ^a ($n=0$) ^a for I/Q points	yes
EORFspectr - EDGE output RF spectrum (EDGE mode)	RFEMod ($n=2$) ^a RFESwitching ($n=3$) ^a SPEMod ($n=4$) ^a LIMMod ($n=5$) ^a ($n=0$) ^a for I/Q points	yes, only for a single offset yes, only for multiple offsets
EPVTime - EDGE power versus time (EDGE mode)	RFENvelope ($n=2$) ^a UMASk ($n=3$) ^a LMASk ($n=4$) ^a ($n=0$) ^a for I/Q points	yes
ETSPur - EDGE transmit band spurs (EDGE mode)	SPECtrum ($n=2$) ^a ULIMit ($n=3$) ^a ($n=0$) ^a for I/Q points	yes
EVM - error vector magnitude (NADC, PDC modes)	EVM ($n=2$) ^a MERRor ($n=3$) ^a PERRor ($n=4$) ^a ($n=0$) ^a for I/Q points	yes

Measurement	Available Traces	Markers Available?
EVMQpsk - QPSK error vector magnitude (cdma2000, W-CDMA modes)	EVM ($n=2$) ^a MERRor ($n=3$) ^a PERRor ($n=4$) ^a ($n=0$) ^a for I/Q points	yes
IM - intermodulation (cdma2000, W-CDMA modes)	SPECTrum ($n=2$) ^a ($n=0$) ^a for I/Q points	yes
MCPower - multi-carrier power (W-CDMA mode)	no traces ($n=0$) ^a for I/Q points	no markers
OBW - occupied bandwidth (cdmaOne, cdma2000, PDC, W-CDMA modes)	no traces ($n=0$) ^a for I/Q points	no markers
ORFSpectrum - output RF spectrum (GSM, EDGE mode)	RFEMod ($n=2$) ^a RFESwitching ($n=3$) ^a SPEMod ($n=4$) ^a LIMMod ($n=5$) ^a ($n=0$) ^a for I/Q points	yes, only for a single offset yes, only for multiple offsets
PFERror - phase and frequency error (GSM, EDGE mode)	PERRor ($n=2$) ^a PFERror ($n=3$) ^a RFENvelope ($n=4$) ^a ($n=0$) ^a for I/Q points	yes
PSTatistic - power statistics CCDF (Basic, cdma2000, W-CDMA modes)	MEASured ($n=2$) ^a GAUSian ($n=3$) ^a REFerence ($n=4$) ^a ($n=0$) ^a for I/Q points	yes
PVTime - power versus time (GSM, EDGE modes)	RFENvelope ($n=2$) ^a UMASk ($n=3$) ^a LMASk ($n=4$) ^a ($n=0$) ^a for I/Q points	yes

Measurement	Available Traces	Markers Available?
RHO - modulation quality (cdmaOne, cdma2000, W-CDMA mode)	($n=0$) ^a for I/Q points EVM ($n=2$) ^a MERRor ($n=3$) ^a PERRor ($n=4$) ^a ($n=0$) ^a for I/Q points	yes
SEMAsk - spectrum emissions mask (cdma2000, W-CDMA mode)	SPECtrum ($n=2$) ^a ($n=0$) ^a for I/Q points	yes
TSPur - transmit band spurs (GSM, EDGE mode)	SPECtrum ($n=2$) ^a ULIMit ($n=3$) ^a ($n=0$) ^a for I/Q points	yes
TXPower - transmit power (GSM, EDGE mode)	RFENvelope ($n=2$) ^a IQ ($n=8$) ^a ($n=0$) ^a for I/Q points	yes
SPECtrum - (frequency domain) (all modes)	IQ ($n=3$) ^a SPECtrum ($n=4$) ^a ASPectrum ($n=7$) ^a ($n=0$) ^a for I/Q points	yes
WAVEform - (time domain) (all modes)	RFENvelope ($n=2$) ^a (also for Signal Envelope trace) IQ ($n=5$) ^a ($n=0$) ^a for I/Q points	yes

a. The n number indicates the sub-opcode that corresponds to this trace. Detailed descriptions of the trace data can be found in the MEASure subsystem documentation by looking up the sub-opcode for the appropriate measurement.

Waveform - Y-Axis Scale/Div

```
:DISPlay:WAVEform[n]:WINDow[m]:TRACe:Y[:SCALE]:PDIVision
<power>
```

:DISPlay:WAVEform[n]:WINDow[m]:TRACe:Y[:SCALE]:PDIVision?

Sets the scale per division for the y-axis.

n, selects the view, the default is RF envelope.

n=1, m=1 RF envelope

n=2, m=1 I/Q Waveform

n=4, m=1 I/Q Polar (Basic, W-CDMA, cdma2000)

m, selects the window within the view. The default is 1.

Factory Preset: 10 dBm, for RF envelope

Range: .1 dB to 20 dB, for RF envelope

Default Unit: dBm, for RF envelope

Remarks: May affect input attenuator setting.

You must be in Basic, cdmaOne, cdma2000, W-CDMA
 GSM w/EDGE, NADC, or PDC mode. Set the mode with
 INSTRument:SElect.

Front Panel

Access: When in Waveform measurement: **Amplitude Y Scale,
 Scale/Div.**

History: Added revision A.02.00

Waveform - Y-Axis Reference Level

:DISPlay:WAVEform[n]:WINDow[m]:TRACe:Y[:SCALE]:RLEVEL
 <power>

:DISPlay:WAVEform[n]:WINDow[m]:TRACe:Y[:SCALE]:RLEVEL?

Sets the amplitude reference level for the y-axis.

n, selects the view, the default is RF envelope.

n=1, m=1 RF envelope

n=2, m=1 I/Q Waveform

n=4, m=1 I/Q Polar (Basic, W-CDMA, cdma2000)

m, selects the window within the view. The default is 1.

Factory Preset: 0 dBm, for RF envelope

Range: -250 to 250 dBm, for RF envelope

Default Unit: dBm, for RF envelope

Remarks: May affect input attenuator setting.

You must be in Basic, cdmaOne, cdma2000, W-CDMA

GSM w/EDGE, NADC, or PDC mode. Set the mode with
INSTrument:SElect.

Front Panel

Access: When in Waveform measurement: **Amplitude Y Scale,**
Ref Level

History: Added revision A.02.00

FETCh Subsystem

The FETCh? queries are used with several other commands to control the measurement process. These commands are described in the section on the “[MEASure Group of Commands](#)” on page 206. These commands apply only to measurements found in the MEASURE menu.

[ESA-all and PSA-PN]This command puts selected data from the most recent measurement into the output buffer (new data is initiated/measured). Use FETCh if you have already made a good measurement and you want to look at several types of data (different [n] values) from the single measurement. FETCh saves you the time of re-making the measurement. You can only fetch results from the measurement that is currently active.

If you need to make a new measurement, use the READ command, which is equivalent to an INITiate[:IMMEDIATE] followed by a FETCh.

:FETCh <meas>? will return valid data only when the measurement is in one of the following states:

- idle
- initiated
- paused

Fetch the Current Measurement Results

:FETCh: <measurement> [n]?

A FETCh? command must specify the desired measurement. It will return the valid results that are currently available, but will not initiate the taking of any new data. You can only fetch results from the measurement that is currently selected. The code number n selects the kind of results that will be returned. The available measurements and data results are described in the “[MEASure Group of Commands](#)” on page 206.

FORMat Subsystem

The FORMat subsystem sets a data format for transferring numeric and array information. [Not PN]The TRACe[:DATA] command is affected by FORMat subsystem commands.

Byte Order

`:FORMat:BORDER NORMAL|SWAPPED`

`:FORMat:BORDER?`

Selects the binary data byte order for numeric data transfer. In normal mode the most significant byte is sent first. In swapped mode the least significant byte is first. (PCs use the swapped order.) Binary data byte order functionality does not apply to ASCII.

Factory Preset: Normal

Numeric Data format

`:FORMat[:DATA] ASCii|REAL,32|REAL,64`

`:FORMat[:DATA]?`

This command controls the format of data output, that is, data transfer across any remote port. The REAL and ASCII formats will format trace data in the current amplitude units.

The format of state data cannot be changed. It is always in a machine readable format only.

ASCII - Amplitude values are in ASCII, in amplitude units, separated by commas. ASCII format requires more memory than the binary formats. Therefore, handling large amounts of this type of data, will take more time and storage space.

Real,32 (or 64) - Binary 32-bit (or 64-bit) real values in amplitude unit, in a definite length block. Transfers of real data are done in a binary block format.

A definite length block of data starts with an ASCII header that begins with # and indicates how many additional data points are following in the block. Suppose the header is #512320.

- The first digit in the header (5) tells you how many additional digits/bytes there are in the header.
- The 12320 means 12 thousand, 3 hundred, 20 data bytes follow the

header.

- Divide this number of bytes by your selected data format bytes/point, either 8 (for real 64), or 4 (for real 32). In this example, if you are using real 64 then there are 1540 points in the block.

Example: FORM REAL,64

Factory Preset: Real,32 for Spectrum Analysis mode

 ASCII for Basic, cdmaOne, cdma2000, W-CDMA, GSM
 with EDGE, NADC, PDC modes

Remarks: The acceptable settings for this command changes for
 different modes.

INITiate Subsystem

The INITiate subsystem is used to initiate a trigger for a measurement. They only initiate measurements from the MEASURE front panel key or the “MEASure Group of Commands” on page 206. Refer to the TRIGger and ABORt subsystems for related commands.

Take New Data Acquisition for Selected Measurement

:INITiate:<measurement_name>

This command initiates a trigger cycle for the measurement specified. The available measurement names are described in the MEASURE subsystem. It also holds off additional commands on GPIB until the acquisition is complete. So if it is followed by a FETCh command, valid data will be returned.

If your selected measurement is currently active (in the idle state) it triggers the measurement, assuming the trigger conditions are met. Then it completes one trigger cycle. Depending upon the measurement and the number of averages, there may be multiple data acquisitions, with multiple trigger events, for one full trigger cycle.

If your selected measurement is not currently active it will change to the measurement in your INIT:<meas_name> command and initiate a trigger cycle.

Example: INIT:ACP

Continuous or Single Measurements

:INITiate:CONTinuous OFF|ON|0|1

:INITiate:CONTinuous?

Selects whether a trigger is continuously initiated or not. Each trigger initiates a single, complete, measurement operation.

When set to ON another trigger cycle is initiated at the completion of each measurement.

When set to OFF, the trigger system remains in the “idle” state until an INITiate[:IMMediate] command is received. On receiving the INITiate[:IMMediate] command, it will go through a single trigger/measurement cycle, and then return to the “idle” state.

Example: INIT:CONT ON

Factory Preset: On

*RST: Off (recommended for remote operation)

Front Panel
Access: **Meas Control, Measure Cont Single**

Take New Data Acquisitions

:INITiate[:IMMEDIATE]

The instrument must be in the single measurement mode. If INIT:CONT is ON, then the command is ignored. The desired measurement must be selected and waiting. The command causes the system to exit the “waiting” state and go to the “initiated” state.

The trigger system is initiated and completes one full trigger cycle. It returns to the “waiting” state on completion of the trigger cycle. Depending upon the measurement and the number of averages, there may be multiple data acquisitions, with multiple trigger events, for one full trigger cycle.

This command triggers the instrument, if external triggering is the type of trigger event selected. Otherwise, the command is ignored. Use the TRIGger[:SEQUENCE]:SOURce EXT command to select the external trigger.

Example: INIT:IMM

Remarks: See also the *TRG command and the TRIGger subsystem.

Front Panel
Access: **Meas Control, Measure Cont Single**

Restart the Measurement

:INITiate:REStart

This command applies to measurements found in the MEASURE menu. It restarts the current measurement from the “idle” state regardless of its current operating state. It is equivalent to:

INITiate[:IMMEDIATE]

ABORt (for continuous measurement mode)

Example: INIT:REST

Front Panel
Access: **Restart**

or

Meas Control, Restart

INSTrument Subsystem

This subsystem includes commands for querying and selecting instrument measurement (personality option) modes.

Catalog Query

:INSTrument:CATalog[:FULL]?

Returns a comma separated list of strings which contains the names of all the installed applications. These names can only be used with the **INST:SELEct** command. If the optional keyword **FULL** is specified, each name is immediately followed by its associated instrument number. These instrument numbers can only be used with the **INST:NSELEct** command.

Example: **INST:CAT:FULL?**

Query response:
 "BASIC"8,"GSM"3,"CDMA"4,"SERVICE"1

Select Application by Number

:INSTrument:NSELEct <integer>

:INSTrument:NSELEct?

Select the measurement mode by its instrument number. The actual available choices depends upon which applications are installed in the instrument. These instrument numbers can be obtained with **INST:CATalog:FULL?**

- 1 = SERVICE
- 3 = GSM
- 4 = CDMA (cdmaOne)
- 5 = NADC
- 6 = PDC
- 8 = BASIC
- 9 = WCDMA (3GPP)
- 10 = CDMA2K (cdma2000)
- 11 = IDEN
- 13 = EDGE GSM
- 15 = CMDA1XEV (1xEV-D0)

NOTE

If you are using the SCPI status registers and the analyzer mode is changed, the status bits should be read, and any errors resolved, prior to switching modes. Error conditions that exist prior to switching modes cannot be detected using the condition registers after the mode change. This is true unless they recur after the mode change, although transitions of these conditions can be detected using the event registers.

Changing modes resets all SCPI status registers and mask registers to their power-on defaults. Hence, any event or condition register masks must be re-established after a mode change. Also note that the power up status bit is set by any mode change, since that is the default state after power up.

Example: INST:NSEL 4

Factory Preset: Persistent state with factory default of 8 (BASIC)

Range: 1 to x, where x depends upon which applications are installed.

Front Panel

Access: **MODE**

Select Application

VSA E4406A:

```
:INSTrument[:SElect]
BASIC|SERVICE|CDMA|CDMA2K|GSM|EDGEgsm|IDEN|NADC|PDC|
WCDMA|CDMA1XEV
```

```
:INSTrument[:SElect]?
```

Select the measurement mode. The actual available choices depend upon which modes (measurement applications) are installed in the instrument. A list of the valid choices is returned with the INST:CAT? query.

Once an instrument mode is selected, only the commands that are valid for that mode can be executed.

- 1 = SERVICE
- 3 = GSM
- 4 = CDMA (cdmaOne)
- 5 = NADC
- 6 = PDC
- 8 = BASIC
- 9 = WCDMA (3GPP)
- 10 = CDMA2K (cdma2000)
- 11 = IDEN

13 = EDGE GSM
15 = CDMA1XEV (1xEV-D0)

NOTE

If you are using the status bits and the analyzer mode is changed, the status bits should be read, and any errors resolved, prior to switching modes. Error conditions that exist prior to switching modes cannot be detected using the condition registers after the mode change. This is true unless they recur after the mode change, although transitions of these conditions can be detected using the event registers.

Changing modes resets all SCPI status registers and mask registers to their power-on defaults. Hence, any event or condition register masks must be re-established after a mode change. Also note that the power up status bit is set by any mode change, since that is the default state after power up.

Example: ESA Series instruments: INST:SEL 'CDMA'

Example: PSA Series instruments: INST:SEL CDMA

Factory Preset: Persistent state with factory default of Basic mode.

Front Panel

Access: **MODE**

MEASure Group of Commands

This group includes the CONFigure, FETCh, MEASure, and READ commands that are used to make measurements and return results. The different commands can be used to provide fine control of the overall measurement process, like changing measurement parameters from their default settings. Most measurements should be done in single measurement mode, rather than measuring continuously.

The SCPI default for the format of any data output is ASCII. The format can be changed to binary with FORMat:DATA which transports faster over the bus.

CONFigure, FETCh, MEASure, READ Interactions

These commands are all inter-related. See [Figure 4-3 on page 207](#).

Measure Commands

:MEASure:<measurement>[n]?

This is a fast single-command way to make a measurement using the factory default instrument settings. These are the settings and units that conform to the Mode Setup settings (e.g. radio standard) that you have currently selected.

- Stops the current measurement (if any) and sets up the instrument for the specified measurement using the factory defaults
- Initiates the data acquisition for the measurement
- Blocks other SCPI communication, waiting until the measurement is complete before returning results.
- After the data is valid it returns the scalar results, or the trace data, for the specified measurement. The type of data returned may be defined by an [n] value that is sent with the command.

The scalar measurement results will be returned if the optional [n] value is not included, or is set to 1. If the [n] value is set to a value other than 1, the selected trace data results will be returned. See each command for details of what types of scalar results or trace data results are available.

ASCII is the default format for the data output. The binary data formats should be used for handling large blocks of data since they are smaller and faster than the ASCII format. Refer to the FORMat:DATA command for more information.

If you need to change some of the measurement parameters from the factory default settings you can set up the measurement with the CONFigure command. Use the commands in the

SENSE:<measurement> and CALCulate:<measurement> subsystems to change the settings. Then you can use the READ? command to initiate the measurement and query the results. See [Figure 4-3](#).

If you need to repeatedly make a given measurement with settings other than the factory defaults, you can use the commands in the SENSE:<measurement> and CALCulate:<measurement> subsystems to set up the measurement. Then use the READ? command to initiate the measurement and query results.

Measurement settings persist if you initiate a different measurement and then return to a previous one. Use READ:<measurement>? if you want to use those persistent settings. If you want to go back to the default settings, use MEASure:<measurement>?.

Figure 4-3 Measurement Group of Commands

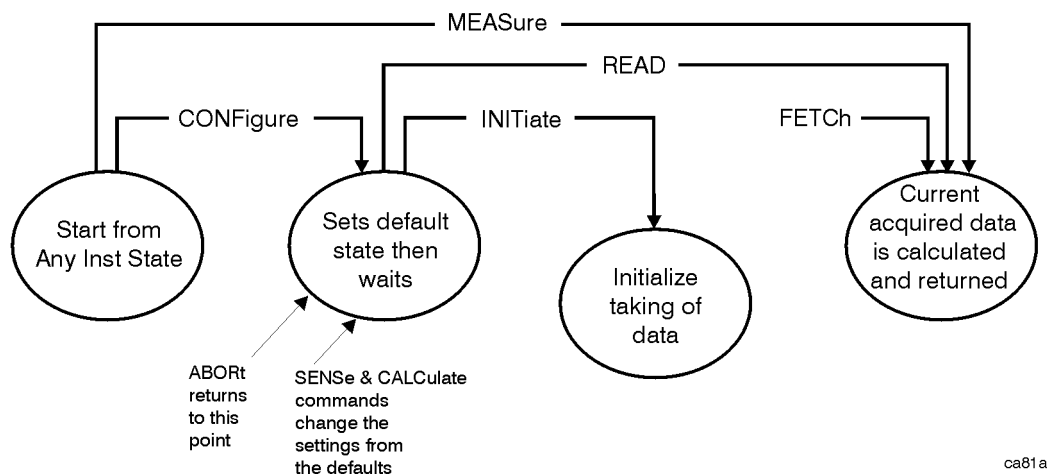

Configure Commands

:CONFigure:<measurement>

This command stops the current measurement (if any) and sets up the instrument for the specified measurement using the factory default instrument settings. It sets the instrument to single measurement mode but should not initiate the taking of measurement data unless INIT:CONTinuous is ON. After you change any measurement settings, the READ command can be used to initiate a measurement without changing the settings back to their defaults.

The CONFigure? query returns the current measurement name.

Initiate Commands

:INITiate:<measurement>

- Initiates a trigger cycle for the specified measurement, but does not output any data. You must then use the FETCh<meas> command to return data. If a measurement other than the current one is specified, the instrument will switch to that measurement and then initiate it.

For example, suppose you have previously initiated the ACP measurement, but now you are running the channel power measurement. If you send INIT:ACP? it will change from channel power to ACP and will initiate an ACP measurement.

- Does not change any of the measurement settings. For example, if you have previously started the ACP measurement and you send INIT:ACP? it will initiate a new ACP measurement using the same instrument settings as the last time ACP was run.
- If your selected measurement is currently active (in the idle state) it triggers the measurement, assuming the trigger conditions are met. Then it completes one trigger cycle. Depending upon the measurement and the number of averages, there may be multiple data acquisitions, with multiple trigger events, for one full trigger cycle. It also holds off additional commands on GPIB until the acquisition is complete.

Fetch Commands

:FETCh:<measurement>[n]?

This command puts selected data from the most recent measurement into the output buffer. Use FETCh if you have already made a good measurement and you want to return several types of data (different [n] values, e.g. both scalars and trace data) from a single measurement. FETCh saves you the time of re-making the measurement. You can only FETCh results from the measurement that is currently active, it will not change to a different measurement.

If you need to get new measurement data, use the READ command, which is equivalent to an INITiate followed by a FETCh.

The scalar measurement results will be returned if the optional [n] value is not included, or is set to 1. If the [n] value is set to a value other than 1, the selected trace data results will be returned. See each command for details of what types of scalar results or trace data results are available. The binary data formats should be used for handling large blocks of data since they are smaller and transfer faster than the ASCII format. (FORMat:DATA)

FETCh may be used to return results other than those specified with the original READ or MEASure command that you sent.

Read Commands

:READ:<measurement>[n]?

- Does not preset the measurement to the factory default settings. For example, if you have previously initiated the ACP measurement and you send READ:ACP? it will initiate a new measurement using the same instrument settings.
- Initiates the measurement and puts valid data into the output buffer. If a measurement other than the current one is specified, the instrument will switch to that measurement before it initiates the measurement and returns results.

For example, suppose you have previously initiated the ACP measurement, but now you are running the channel power measurement. Then you send READ:ACP? It will change from channel power back to ACP and, using the previous ACP settings, will initiate the measurement and return results.

- Blocks other SCPI communication, waiting until the measurement is complete before returning the results

If the optional [n] value is not included, or is set to 1, the scalar measurement results will be returned. If the [n] value is set to a value other than 1, the selected trace data results will be returned. See each command for details of what types of scalar results or trace data results are available. The binary data formats should be used when handling large blocks of data since they are smaller and faster than the ASCII format. (FORMat:DATA)

EDGE Error Vector Magnitude Measurement

This measures the vector error of the magnitude of each symbol. You must be in the EDGE(w/GSM) mode to use these commands. Use INSTRument:SElect to set the mode.

The general functionality of CONFigure, FETCh, MEASure, and READ are described at the beginning of this section. See the SENSE:EEVM commands for more measurement related commands.

:CONFigure:EEVM

:INITiate:EEVM

:FETCh:EEVM[n]?

:READ:EEVM[n]?

:MEASure:EEVM[n]?

History: Version A.04.00 or later

Front Panel

Access: **Measure, EDGE EVM**

After the measurement is selected, press **Restore Meas Defaults** to restore factory defaults.

Measurement Results Available

n	Results Returned
0	Returns unprocessed I/Q trace data, as a data array of comma-separated trace points, in volts.

n	Results Returned
1 (default)	<p>Returns the following 13 comma-separated scalar results, in order.</p> <ol style="list-style-type: none"> 1. RMS 95th %tile EVM – a floating point number (in percent) of EVM over 95% of the entire measurement area. 2. RMS EVM – a floating point number (in percent) of EVM over the entire measurement area. 3. Maximum RMS EVM – a floating point number (in percent) of highest EVM over the entire measurement area. 4. Peak EVM – a floating point number (in percent) of the average of the peak EVMs. Take the peak EVMs from each burst and average them together. 5. Maximum peak EVM – a floating point number (in percent) of the maximum peak EVM. Take the peak EVMs from each burst and identify the highest peak. 6. Symbol position of the peak EVM error – an integer number of the symbol position where the peak EVM error is detected. 7. Magnitude error – a floating point number (in percent) of average magnitude error over the entire measurement area. 8. Maximum magnitude error – a floating point number (in percent) of maximum magnitude error over the entire measurement area. 9. Phase error – a floating point number (in degree) of average phase error over the entire measurement area. 10. Maximum Phase error – a floating point number (in degree) of maximum phase error over the entire measurement area. 11. Frequency error – a floating point number (in Hz) of the frequency error in the measured signal. 12. Maximum frequency error – a floating point number (in Hz) of the highest frequency error in the measured signal. 13. I/Q origin offset – a floating point number (in dB) of the I and Q error (magnitude squared) offset from the origin.
2	<p>Returns series of floating point numbers (in percent) that represent each sample in the EVM vector trace for the last slot. The first number is the symbol 0 decision point and there are 5 points per symbol. Therefore, the decision points are at 0, 5, 10, 15. . . .</p>
3	<p>Returns series of floating point numbers (in percent) that represent each sample in the magnitude error vector trace for the last slot. The first number is the symbol 0 decision point and there are 5 points per symbol. Therefore, the decision points are at 0, 5, 10, 15. . . .</p>
4	<p>Returns series of floating point numbers (in degree) that represent each sample in the phase error vector trace for the last slot. The first number is the symbol 0 decision point and there are 5 points per symbol. Therefore, the decision points are at 0, 5, 10, 15</p>

n	Results Returned
5	<p>Returns series of floating point numbers that alternately represent I and Q pairs of the final corrected measured data for the last slot. The magnitude of each I and Q pair are normalized to 1.0. The first number is the in-phase (I) sample of symbol 0 decision point and the second is the quadrature-phase (Q) sample of symbol 0 decision point. As in the EVM, there are 5 points per symbol, so the series of numbers is:</p> <p>1st number = I of the symbol 0 decision point 2nd number = Q of the symbol 0 decision point . . . (2 × 5) + 1 (or 11th) number = I of the symbol 1 decision point (2 × 5) + 2 (or 12th) number = Q of the symbol 1 decision point . . . (2 × 5) × N + 1 number = I of the symbol N decision point (2 × 5) × N + 2 number = Q of the symbol N decision point</p>

EDGE Output RF Spectrum Measurement

This measures adjacent channel power. From 1 to 15 offsets can be measured at one time. You must be in the EDGE(w/GSM) mode to use these commands. Use INSTRument:SElect to set the mode.

The general functionality of CONFigure, FETCh, MEASure, and READ are described at the beginning of this section. See the SENSE:EORFspectr commands for more measurement related commands.

:CONFigure:EORFspectr

:INITiate:EORFspectr

:FETCh:EORFspectr[n]?

:READ:EORFspectr[n]?

:MEASure:EORFspectr[n]?

History: Version A.04.00 or later. Modified in version A.05.00.

Front Panel

Access: **Measure, EDGE Output RF Spectrum**

After the measurement is selected, press **Restore Meas Defaults** to restore factory defaults.

Measurement Results Available

The default settings for the MEASure command only measure the carrier and 5 standard offsets. The default does not measure the switching transients. If you use the CONFigure, INITiate, and FETCh commands in place of the MEASure command, you can then use the SENSE commands to change the settings from these defaults. Use [:SENSE]:EORFspectr:LIST:SWITCh CUSTOM to select a customized set of offsets. Use [:SENSE]:EORFspectr:TYPE MSWitching to measure switching in addition to measuring modulation. (The measurement will take longer when measuring switching transients.)

Measurement Method	n	Results Returned
	0	Returns unprocessed I/Q trace data, as a series of comma-separated trace points, in volts. The I values are listed first in each pair, using the 0 through even-indexed values. The Q values are the odd-indexed values.

Measurement Method	n	Results Returned
Single Offset	not specified or n=1	<p>Returns 4 comma-separated results for the specified offset:</p> <ol style="list-style-type: none"> 1. Modulation spectrum power, dB 2. Modulation spectrum power, dBm 3. Switching transient power, dB 4. Switching transient power, dBm
Multiple Offsets Switching -or- Multiple Offsets Modulation Discrete Mode	not specified or n=1	<p>Returns a list of comma-separated values for the modulation spectrum at all the offsets (lower and upper.) This is followed by the switching transients results at all the offsets (lower and upper). Note that the carrier is considered offset zero (0) and is the first set of results sent. Four values are provided for each of the offsets (including the carrier), in this order:</p> <ol style="list-style-type: none"> 1. Negative offset(a) - power relative to carrier (dB) 2. Negative offset(a) - absolute average power (dBm) 3. Positive offset(a) - power relative to carrier (dB) 4. Positive offset(a) - absolute average power (dBm) <p>Values for all possible offsets are sent. Zeros are sent for offsets that have not been defined. The total number of values sent $(120) = (4 \text{ results/offset}) \times (15 \text{ offsets}) \times (2 \text{ measurement types - modulation \& switching})$</p> <p>Carrier - modulation measurement values Offset 1 - modulation measurement values ... Offset 14 - modulation measurement values Carrier - switching transients measurement values Offset 1 - switching transients measurement values ... Offset 14- switching transients measurement values</p> <p>This measurement defaults to modulation measurements and not switching measurements. If you want to return the switching measurement values, you must change that default condition and use FETCh or READ to return values, rather than MEASure.</p> <p>NOTE: When using custom modulation and switching offsets the maximum number of measured values returned is:</p> <p>13 modulation offsets + 0 Hz carrier 4 switching offsets + 0 Hz carrier</p>
Multiple Offsets Modulation Sweep Mode	not specified or n=1	<p>Returns 5 comma-separated results of the closest point to the limit line:</p> <ol style="list-style-type: none"> 1. Frequency 2. Offset frequency from carrier frequency 3. Power in dBm 4. delta from limit (dB) 5. delta from reference (dB)

Measurement Method	n	Results Returned
Single Offset	2	Returns floating point numbers (in dBm) of the captured trace data. It contains N data points of the “spectrum due to modulation” signal, where N is the specified number of samples.
Single Offset	3	Returns floating point numbers (in dBm) of the captured trace data. It contains N data points of the “spectrum due to switching transients” signal, where N is the specified number of samples.
Multiple Offsets Modulation	4	Returns floating point numbers (in dBm) of the sweep spectrum of modulation.
Sweep Mode	5	Returns floating point numbers (in dBm) of the limit trace.

EDGE Power vs. Time Measurement

This measures the average power during the “useful part” of the burst comparing the power ramp to required timing mask. You must be in EDGE(w/GSM) mode to use these commands. Use INSTRument:SElect to set the mode.

The general functionality of CONFigure, FETCh, MEASure, and READ are described at the beginning of this section. See the SENSE:EPVTime commands for more measurement related commands.

:CONFigure:EPVTime

:INITiate:EPVTime

:FETCh:EPVTime[n]?

:READ:EPVTime[n]?

:MEASure:EPVTime[n]?

Front Panel

Access: **Measure, EDGE Pwr vsTime**

After the measurement is selected, press **Restore Meas Defaults** to restore factory defaults.

History: **Modified in version A.05.00.**

Measurement Results Available

n	Results Returned
0	Returns unprocessed I/Q trace data, as a series of comma-separated trace points, in volts. The I values are listed first in each pair, using the 0 through even-indexed values. The Q values are the odd-indexed values.

n	Results Returned
not specified or n=1	<p>Returns the following comma-separated scalar results:</p> <ol style="list-style-type: none"> 1. Sample time is a floating point number that represents the time between samples when using the trace queries (n=0,2,etc.). 2. Power single burst is the mean power (in dBm) across the useful part of the selected burst in the most recently acquired data, or in the last data acquired at the end of a set of averages. If averaging is on, the power is for the last burst. 3. Power averaged is the power (in dBm) of N averaged bursts, if averaging is on. The power is averaged across the useful part of the burst. Average <i>m</i> is a single burst from the acquired trace. If there are multiple bursts in the acquired trace, only one burst is used for average <i>m</i>. This means that N traces are acquired to make the complete average. If averaging is off, the value of power averaged is the same as the power single burst value. 4. Number of samples is the number of data points in the captured signal. This number is useful when performing a query on the signal (i.e. when n=0,2,etc.). 5. Start is the index of the data point at the start of the useful part of the burst 6. Stop is the index of the data point at the end of the useful part of the burst 7. T₀ is the index of the data point where t₀ occurred 8. Burst width is the width of the burst measured at -3dB below the mean power in the useful part of the burst. 9. Maximum value is the maximum value of the most recently acquired data (in dBm). 10. Minimum value is the minimum value of the most recently acquired data (in dBm). 11. Burst search threshold is the value (in dBm) of the threshold where a valid burst is identified, after the data has been acquired. 12. IQ point delta is the number of data points offset that are internally applied to the useful data in traces n=2,3,4. You must apply this correction value to find the actual location of the Start, Stop, or T₀ values. (e.g. for n=2, Start (for the IQ trace data) = Start + IQ_point_delta)
2	Returns comma-separated trace points of the entire waveform data. These data points are floating point numbers representing the power of the signal (in dBm). There are N data points, where N is the number of samples . The period between the samples is defined by the sample time .
3	Returns comma-separated points representing the upper mask (in dBm).
4	Returns comma-separated points representing the lower mask (in dBm).
7	Returns power level values for the 8 slots in the current frame (in dBm).

n	Results Returned
8, only available when averaging is set to both maximum and minimum	<p>Returns comma-separated trace points of the minimum waveform data. These data points are floating point numbers representing the power of the signal (in dBm). There are N data points, where N is the number of samples. The period between the samples is defined by the sample time.</p> <p>Use SENSE:PVT:AVERAge:TYPE MXMinimum to set averaging to max and min. Use n=2 to return the corresponding maximum trace.</p>

EDGE Transmit Band Spurs Measure Commands

This measures the spurious emissions in the transmit band relative to the channel power in the selected channel. You must be in the EDGE mode to use these commands. Use INSTRument:SELEct to set the mode.

:CONFigure:ETSPur

The general functionality of CONFigure, FETCh, MEASure, and READ are described at the beginning of this section. See the SENSE:TSPur commands for more measurement related commands.

:FETCh:ETSPur[n]?

:INITiate:ETSPur

:READ:ETSPur[n]?

:MEASure:ETSPur[n]?

History: Version A.05.00 or later

Front Panel

Access: **Measure, EDGE Tx Band Spurs**

After the measurement is selected, press **Restore Meas Defaults** to restore factory defaults.

Measurement Results Available

n	Results Returned
0	Returns unprocessed I/Q trace data, as a series of trace points, in volts. The I values are listed first in each pair, using the 0 through even-indexed values. The Q values are the odd-indexed values.
Not specified or n=1	Returns 3 scalar results: <ol style="list-style-type: none"> 1. The worst spur's frequency difference from channel center frequency (in MHz) 2. The worst spur's amplitude difference from the limit (in dB) 3. The worst spur's amplitude difference from the mean transmit power (in dB)
2	Returns trace of the segment containing the worst spur.

Output RF Spectrum Measurement

This measures adjacent channel power. From 1 to 15 offsets can be measured at one time. You must be in the EDGE, GSM mode to use these commands. Use INSTRument:SElect to set the mode.

The general functionality of CONFigure, FETCh, MEASure, and READ are described at the beginning of this section. See the SENSE:ORFSpectrum commands for more measurement related commands.

:CONFigure:ORFSpectrum

:INITiate:ORFSpectrum

:FETCh:ORFSpectrum[n]?

:READ:ORFSpectrum[n]?

:MEASure:ORFSpectrum[n]?

Front Panel

Access: **Measure, Output RF Spectrum**

After the measurement is selected, press **Restore Meas Defaults** to restore factory defaults.

Measurement Results Available

The default settings for the MEASure command only measure the carrier and 5 standard offsets. The default does not measure the switching transients. If you use the CONFigure, INITiate, and FETCh commands in place of the MEASure command, you can then use the SENSE commands to change the settings from these defaults. Use [:SENSE]:ORFSpectrum:LIST:SWITCh CUSTOM to select a customized set of offsets. Use [:SENSE]:ORFSpectrum:TYPE MSWitching to measure switching in addition to measuring modulation. (The measurement will take longer when measuring switching transients.)

Measurement Method	n	Results Returned
	0	Returns unprocessed I/Q trace data, as a series of comma-separated trace points, in volts. The I values are listed first in each pair, using the 0 through even-indexed values. The Q values are the odd-indexed values.
Single Offset	not specified or n=1	Returns 4 comma-separated results for the specified offset: <ol style="list-style-type: none"> 1. Modulation spectrum power, dB 2. Modulation spectrum power, dBm 3. Switching transient power, dB 4. Switching transient power, dBm

Measurement Method	n	Results Returned
<p>Multiple Offsets Switching -or- Multiple Offsets Modulation Discrete Mode</p>	<p>not specified or n=1</p>	<p>Returns a list of comma-separated values for the modulation spectrum at all the offsets (lower and upper.) This is followed by the switching transients results at all the offsets (lower and upper). Note that the carrier is considered offset zero (0) and is the first set of results sent. Four values are provided for each of the offsets (including the carrier), in this order:</p> <ol style="list-style-type: none"> 1. Negative offset(a) - power relative to carrier (dB) 2. Negative offset(a) - absolute average power (dBm) 3. Positive offset(a) - power relative to carrier (dB) 4. Positive offset(a) - absolute average power (dBm) <p>Values for all possible offsets are sent. Zeros are sent for offsets that have not been defined. The total number of values sent (120) = (4 results/offset) × (15 offsets) × (2 measurement types - modulation & switching)</p> <p>Carrier - modulation measurement values Offset 1 - modulation measurement values ... Offset 14 - modulation measurement values Carrier - switching transients measurement values Offset 1 - switching transients measurement values ... Offset 14- switching transients measurement values</p> <p>This measurement defaults to modulation measurements and not switching measurements. If you want to return the switching measurement values, you must change that default condition and use FETCh or READ to return values, rather than MEASure.</p> <p>NOTE: When using custom modulation and switching offsets the maximum number of measured values returned is:</p> <p>13 modulation offsets + 0 Hz carrier 4 switching offsets + 0 Hz carrier</p>
<p>Multiple Offsets Modulation Sweep Mode</p>	<p>not specified or n=1</p>	<p>Returns 5 comma-separated results of the closest point to the limit line:</p> <ol style="list-style-type: none"> 1. Frequency 2. Offset frequency from carrier frequency 3. Power in dBm 4. delta from limit (dB) 5. delta from reference (dB)
<p>Single Offset</p>	<p>2</p>	<p>Returns floating point numbers (in dBm) of the captured trace data. It contains N data points of the “spectrum due to modulation” signal, where N is the specified number of samples.</p>

Measurement Method	n	Results Returned
Single Offset	3	Returns floating point numbers (in dBm) of the captured trace data. It contains N data points of the “spectrum due to switching transients” signal, where N is the specified number of samples.
Multiple Offsets Modulation, Sweep Mode	4	Returns floating point numbers (in dBm) of the sweep spectrum of modulation.
Multiple Offsets Modulation, Sweep Mode	5	Returns floating point numbers (in dBm) of the limit trace.

Phase & Frequency Error Measurement

This measures the modulation quality of the transmitter by checking phase and frequency accuracy. You must be in the EDGE, GSM mode to use these commands. Use INSTRUMENT:SElect to set the mode.

The general functionality of CONFigure, FETCh, MEASure, and READ are described at the beginning of this section. See the SENSE:PFERror commands for more measurement related commands.

:CONFigure:PFERror

:INITiate:PFERror

:FETCh:PFERror[n]?

:READ:PFERror[n]?

:MEASure:PFERror[n]?

Front Panel

Access: **Measure, Phase & Freq**

After the measurement is selected, press **Restore Meas Defaults** to restore factory defaults.

Measurement Results Available

n	Results Returned
0	Returns unprocessed I/Q trace data, as a series of comma-separated trace points, in volts. The I values are listed first in each pair, using the 0 through even-indexed values. The Q values are the odd-indexed values,

n	Results Returned
not specified or n=1	<p>Returns the following comma-separated scalar results:</p> <ol style="list-style-type: none"> 1. RMS phase error is a floating point number (in degrees) of the rms phase error between the measured phase and the ideal phase. The calculation is based on symbol decision points and points halfway between symbol decision points (i.e. 2 points/symbol). If averaging is on, this is the average of the individual rms measurements. 2. Peak phase error is a floating point number (in degrees) of the peak phase error of all the symbol decision points. rms averaging does not affect this calculation. 3. Peak phase symbol is a floating point number (in symbols) representing the symbol number at which the peak phase error occurred. Averaging does not affect this calculation. 4. Frequency error is a floating point number (in Hz) of the frequency error in the measured signal. This is the difference between the measured phase trajectory and the reference phase trajectory. 5. I/Q origin offset is a floating point number (in dB) of the I and Q error (magnitude squared) offset from the origin. 6. Phase sample is a floating point number (in units of bits) representing the time between samples. It is used in querying phase error vector traces. 7. Bit 0 offset is an integer number for the sample point in a phase error vector trace that represents the bit 0 (zero) decision point. The sample points in the trace are numbered 0 to N. 8. Sync start is an integer number for the bit number, within the data bits trace, that represents the start of the sync word. 9. Time sample is a floating point number (in seconds) of the time between samples. It is used in querying time domain traces. For the n=0 trace, of acquired I/Q pairs, this is the time between pairs.
2, and Multi View is the selected view	Returns a series of floating point numbers (in degrees) that represent each sample in the phase error trace. The first number is the symbol 0 decision point and there are 10 points per symbol. Therefore, decision points are at 0, 10, 20, etc.
3, and Multi View is the selected view	Returns a series of floating point numbers (in degrees) that represent each sample in the phase error with frequency trace. Phase error with frequency is the error vector between the measured phase (that has not had frequency compensation) and the ideal reference phase. The calculation is based on symbol decision points and points halfway between symbol decision points (i.e. 2 points/symbol). The first number is the symbol 0 decision point and there are 10 points per symbol. Therefore, decision points are at 0, 10, 20, etc.
4, and Multi View is the selected view	Returns a series of floating point numbers that represent each sample in the log magnitude trace of the original time record. Each number represents a value (in dBm) of the time record.

n	Results Returned
<p>5, and IQ Measured Polar Vector is the selected view</p>	<p>Returns a series of floating point numbers that alternately represent I and Q pairs of the corrected measured trace. The magnitude of each I and Q pair are normalized to 1.0. The first number is the in-phase (I) sample of symbol 0 decision point and the second is the quadrature-phase (Q) sample of symbol 0 decision point. As in the rms phase error, there are ten points per symbol, so that:</p> <p style="padding-left: 40px;">1st number = I of the symbol 0 decision point 2nd number = Q of the symbol 0 decision point .. 10th number = Q of the symbol 0 decision point 11th number = I of the symbol 1 decision point 12th number = Q of the symbol 1 decision point .. 10 × Nth number = Q of the symbol N decision point</p>
<p>6, and Multi View is the selected view</p>	<p>Returns a series of logical values (0 or 1) that represent the demodulated bit value of the measured waveform. The first number is the symbol 0 decision point and there are 10 points per symbol. Therefore, decision points are at 0, 10, 20, etc.</p>

Power vs. Time Measurement

This measures the average power during the “useful part” of the burst comparing the power ramp to required timing mask. You must be in EDGE (w/GSM) mode to use these commands. Use INSTRument:SElect to set the mode.

The general functionality of CONFigure, FETCh, MEASure, and READ are described at the beginning of this section. See the SENSE:PVTime commands for more measurement related commands.

:CONFigure:PVTime

:INITiate:PVTime

:FETCh:PVTime[n]?

:READ:PVTime[n]?

:MEASure:PVTime[n]?

Front Panel

Access: **Measure, Power vs Time**

After the measurement is selected, press **Restore Meas Defaults** to restore factory defaults.

History: Modified in version A.05.00..

Measurement Results Available

n	Results Returned
0	Returns unprocessed I/Q trace data, as a series of comma-separated trace points, in volts. The I values are listed first in each pair, using the 0 through even-indexed values. The Q values are the odd-indexed values.

n	Results Returned
not specified or n=1	<p>Returns the following comma-separated scalar results:</p> <ol style="list-style-type: none"> 1. Sample time is a floating point number that represents the time between samples when using the trace queries (n=0,2,etc.). 2. Power of single burst is the mean power (in dBm) across the useful part of the selected burst in the most recently acquired data, or in the last data acquired at the end of a set of averages. If averaging is on, the power is for the last burst. 3. Power averaged is the power (in dBm) of N averaged bursts, if averaging is on. The power is averaged across the useful part of the burst. Average <i>m</i> is a single burst from the acquired trace. If there are multiple bursts in the acquired trace, only one burst is used for average <i>m</i>. This means that N traces are acquired to make the complete average. If averaging is off, the value of power averaged is the same as the power single burst value. 4. Number of samples is the number of data points in the captured signal. This number is useful when performing a query on the signal (i.e. when n=0,2,etc.). 5. Start point of the useful part of the burst is the index of the data point at the start of the useful part of the burst 6. Stop point of the useful part of the burst is the index of the data point at the end of the useful part of the burst 7. Index of the data point where T₀ occurred. 8. Burst width of the useful part of the burst is the width of the burst measured at -3dB below the mean power in the useful part of the burst. 9. Maximum value is the maximum value of the most recently acquired data (in dBm). 10. Minimum value is the minimum value of the most recently acquired data (in dBm). 11. Burst search threshold is the value (in dBm) of the threshold where a valid burst is identified, after the data has been acquired. 12. IQ point delta is the number of data points offset that are internally applied to the useful data in traces n=2,3,4. You must apply this correction value to find the actual location of the Start, Stop, or T₀ values.
2	Returns comma-separated trace points of the entire captured I/Q trace data. These data points are floating point numbers representing the power of the signal (in dBm). There are N data points, where N is the number of samples . The period between the samples is defined by the sample time .
3	Returns comma-separated points representing the upper mask (in dBm).
4	Returns comma-separated points representing the lower mask (in dBm).
7	Returns power level values for the 8 slots in the current frame (in dBm).

n	Results Returned
8, only available when averaging is set to both maximum and minimum	<p>Returns comma-separated trace points of the minimum waveform data. These data points are floating point numbers representing the power of the signal (in dBm). There are N data points, where N is the number of samples. The period between the samples is defined by the sample time.</p> <p>Use SENSE:PVT:AVERAge:TYPE MXMinimum to set averaging to max and min. Use n=2 to return the corresponding maximum trace.</p>

Spectrum (Frequency Domain) Measurement

This measures the amplitude of your input signal with respect to the frequency. It provides spectrum analysis capability using FFT (fast Fourier transform) measurement techniques. You must be in the Basic, cdmaOne, cdma2000, W-CDMA (3GPP), EDGE (w/GSM), NADC, or PDC mode to use these commands. Use INSTRUMENT:SElect, to select the mode.

The general functionality of CONFigure, FETCh, MEASure, and READ are described at the beginning of this section. See the SENSE:SPECTrum commands for more measurement related commands.

:CONFigure:SPECTrum

:INITiate:SPECTrum

:FETCh:SPECTrum[n]?

:READ:SPECTrum[n]?

:MEASure:SPECTrum[n]?

Front Panel

Access: **Measure, Spectrum (Freq Domain)**

After the measurement is selected, press **Restore Meas Defaults** to restore factory defaults.

Measurement Results Available

n	Results Returned
0	Returns unprocessed I/Q trace data, as a series of comma-separated trace points, in volts. The I values are listed first in each pair, using the 0 through even-indexed values. The Q values are the odd-indexed values.

n	Results Returned
not specified or n=1	<p>Returns the following comma-separated scalar results:</p> <ol style="list-style-type: none"> 1. FFT peak is the FFT peak amplitude. 2. FFT frequency is the FFT frequency of the peak amplitude. 3. FFT points is the Number of points in the FFT spectrum. 4. First FFT frequency is the frequency of the first FFT point of the spectrum. 5. FFT spacing is the frequency spacing between the FFT points of the spectrum. 6. Time domain points is the number of points in the time domain trace used for the FFT. The number of points doubles if the data is complex instead of real. See the time domain scaler description below. 7. First time point is the time of the first time domain point, where time zero is the trigger event. 8. Time spacing is the time spacing between the time domain points. The time spacing value doubles if the data is complex instead of real. See the time domain scaler description below. 9. Time domain returns a 1 if time domain is complex (I/Q) and complex data will be returned. It returns a 0 if the data is real. (raw ADC samples) When this value is 1 rather than 0 (complex vs. real data), the time domain points and the time spacing scalers both increase by a factor of two. 10. Scan time is the total scan time of the time domain trace used for the FFT. The total scan time = (time spacing) X (time domain points – 1) 11. Current average count is the current number of data measurements that have already been combined, in the averaging calculation.
3	Returns the I and Q trace data. It is represented by I and Q pairs (in volts) versus time.
4	Returns spectrum trace data. That is, the trace of log-magnitude versus frequency. (The trace is computed using a FFT.)
6	Not used.
7	Returns the averaged spectrum trace data. That is, the trace of the averaged log-magnitude versus frequency.
8	Not used.
11, cdma2000, W-CDMA, Basic modes only	Returns comma-separated linear spectrum trace data in Volts RMS.
12, cdma2000, W-CDMA, Basic modes only	Returns comma-separated averaged linear spectrum trace data in Volts RMS.

Transmit Band Spurs Measurement

This measures the spurious emissions in the transmit band relative to the channel power in the selected channel. You must be in the EDGE, GSM mode to use these commands. Use INSTRUMENT:SElect to set the mode.

The general functionality of CONFigure, FETCh, MEASure, and READ are described at the beginning of this section. See the SENSE:TSPur commands for more measurement related commands.

:CONFigure:TSPur

:INITiate:TSPur

:FETCh:TSPur[n]?

:READ:TSPur[n]?

:MEASure:TSPur[n]?

History: Version A.03.00 or later

Front Panel

Access: **Measure, Tx Band Spurs**

After the measurement is selected, press **Restore Meas Defaults** to restore factory defaults.

Measurement Results Available

n	Results Returned
0	Returns unprocessed I/Q trace data, as a series of comma-separated trace points, in volts. The I values are listed first in each pair, using the 0 through even-indexed values. The Q values are the odd-indexed values.
Not specified or n=1	Returns 3 comma-separated scalar results: <ol style="list-style-type: none"> 1. The worst spur's frequency difference from channel center frequency (in MHz) 2. The worst spur's amplitude difference from the limit (in dB) 3. The worst spur's amplitude difference from the mean transmit power (in dB)
2	Returns trace of the segment containing the worst spur.

Transmit Power Measurement

This measures the power in the channel. It compares the average power of the RF signal burst to a specified threshold value. You must be in the EDGE, GSM mode to use these commands. Use INSTRument:SElect to set the mode.

The general functionality of CONFigure, FETCh, MEASure, and READ are described at the beginning of this section. See the SENSE:TXPower commands for more measurement related commands.

:CONFigure:TXPower

:INITiate:TXPower

:FETCh:TXPower[n]?

:READ:TXPower[n]?

:MEASure:TXPower[n]?

Front Panel

Access: **Measure, Transmit Power**

After the measurement is selected, press **Restore Meas Defaults** to restore factory defaults.

Measurement Results Available

n	Results Returned
0	Returns unprocessed I/Q trace data, as a series of comma-separated trace points, in volts. The I values are listed first in each pair, using the 0 through even-indexed values. The Q values are the odd-indexed values.

n	Results Returned
not specified or n=1	<p>Returns the following comma-separated scalar results:</p> <ol style="list-style-type: none"> 1. Sample time is a floating point number representing the time between samples when using the trace queries (n=0,2,etc). 2. Power is the mean power (in dBm) of the power above the threshold value. If averaging is on, the power is for the latest acquisition. 3. Power averaged is the threshold power (in dBm) for N averages, if averaging is on. An average consists of N acquisitions of data which represents the current trace. If averaging is off, the value of power averaged is the same as the power value. 4. Number of samples is the number of data points in the captured signal. This number is useful when performing a query on the signal (i.e. when n=0,2,etc.). 5. Threshold value is the threshold (in dBm) above which the power is calculated. 6. Threshold points is the number of points that were above the threshold and were used for the power calculation. 7. Maximum value is the maximum of the most recently acquired data (in dBm). 8. Minimum value is the minimum of the most recently acquired data (in dBm).
2	<p>Returns comma-separated trace points of the entire captured trace data. These data points are floating point numbers representing the power of the signal (in dBm). There are N data points, where N is the number of samples. The period between the samples is defined by the sample time.</p>

Waveform (Time Domain) Measurement

This measures the amplitude of your input signal with respect to the frequency. It provides spectrum analysis capability using FFT (fast Fourier transform) measurement techniques. You must be in the Basic, cdmaOne, cdma2000, W-CDMA (3GPP), EDGE (w/GSM), NADC, or PDC mode to use these commands. Use INSTRUMENT:SElect, to select the mode.

The general functionality of CONFigure, FETCh, MEASure, and READ are described at the beginning of this section. See the SENSE:WAVeform commands for more measurement related commands.

:CONFigure:WAVeform

:INITiate:WAVeform

:FETCh:WAVeform[n]?

:READ:WAVeform[n]?

:MEASure:WAVeform[n]?

Front Panel

Access: **Measure, Waveform (Time Domain)**

After the measurement is selected, press **Restore Meas Defaults** to restore factory defaults.

Measurement Results Available

n	Results Returned
0 (see also 5)	Returns unprocessed I/Q trace data, as a series of comma-separated trace points, in volts. The I values are listed first in each pair, using the 0 through even-indexed values. The Q values are the odd-indexed values.

n	Results Returned
not specified or n=1	<p>Returns the following comma-separated scalar results:</p> <ol style="list-style-type: none"> 1. Sample time is a floating point number representing the time between samples when using the trace queries (n=0,2,etc). 2. Mean power is the mean power (in dBm). This is either the power across the entire trace, or the power between markers if the markers are enabled. If averaging is on, the power is for the latest acquisition. 3. Mean power averaged is the power (in dBm) for N averages, if averaging is on. This is either the power across the entire trace, or the power between markers if the markers are enabled. If averaging is on, the power is for the latest acquisition. If averaging is off, the value of the mean power averaged is the same as the value of the mean power. 4. Number of samples is the number of data points in the captured signal. This number is useful when performing a query on the signal (i.e. when n=0,2,etc.). 5. Peak-to-mean ratio has units of dB. This is the ratio of the maximum signal level to the mean power. Valid values are only obtained with averaging turned off. If averaging is on, the peak-to-mean ratio is calculated using the highest peak value, rather than the displayed average peak value. 6. Maximum value is the maximum of the most recently acquired data (in dBm). 7. Minimum value is the minimum of the most recently acquired data (in dBm).
2	<p>Returns comma-separated trace points of the entire captured trace data. These data points are floating point numbers representing the power of the signal (in dBm). There are N data points, where N is the number of samples. The period between the samples is defined by the sample time.</p>
5, cdma2000, W-CDMA, Basic modes only	<p>In input modes other than Ionly and Qonly returns comma-separated values of both I and Q trace data in Volts. The values are in pairs with the I value first. If the input mode is Ionly and Qonly the data returned is comma-separated values of just the I data or the Q data.</p>

READ Subsystem

The READ? commands are used with several other commands and are documented in the section on the “[MEASure Group of Commands](#)” on [page 206](#).

Initiate and Read Measurement Data

:READ: <measurement> [n]?

A READ? query must specify the desired measurement. It will cause a measurement to occur without changing any of the current settings and will return any valid results. The code number n selects the kind of results that will be returned. The available measurements and data results are described in the “[MEASure Group of Commands](#)” on [page 206](#).

SENSe Subsystem

These commands are used to set the instrument state parameters so that you can measure a particular input signal. Some SENSe commands are only for use with specific measurements found under the MEASURE key menu or the [“MEASure Group of Commands” on page 206](#). The measurement must be active before you can use these commands.

The SCPI default for the format of any data output is ASCII. The format can be changed to binary with FORMat:DATA which transports faster over the bus.

Channel Commands

Select the ARFCN—Absolute RF Channel Number

```
[ :SENSe ]:CHANnel:ARFCn|RFCHanne1 <integer>
```

```
[ :SENSe ]:CHANnel:ARFCn|RFCHanne1?
```

Set the analyzer to a frequency that corresponds to the ARFCN (Absolute RF Channel Number).

Factory Preset: 38

Range:

- 0 to 124, and 975 to 1023 for E-GSM
- 1 to 124 for P-GSM
- 0 to 124, and 955 to 1023 for R-GSM
- 512 to 885 for DCS1800
- 512 to 810 for PCS1900
- 259 to 293 for GSM450
- 306 to 340 for GSM480
- 438 to 511 for GSM700
- 128 to 251 for GSM850

Remarks: You must be in the GSM, EDGE mode to use this command. Use INSTRument:SElect to set the mode.
Global to the current mode.

Front Panel

Access: **FREQUENCY Channel, ARFCN**

Select the Lowest ARFCN [VSA-G,E] [PSA-E]

```
[ :SENSe ]:CHANnel:ARFCn|RFCHanne1:BOTTom
```

Set the analyzer to the frequency of the lowest ARFCN (Absolute RF Channel Number) of the selected radio band.

Factory Preset: 975 for E-GSM

1 for P-GSM

955 for R-GSM

512 for DCS1800

512 PCS1900

259 GSM450

306 GSM480

438 GSM700

128 GSM850

Remarks: You must be in the GSM, EDGE mode to use this command. Use INSTRUMENT:SElect to set the mode.
Global to the current mode.

Front Panel

Access: **FREQUENCY Channel, BMT Freq**

Select the Middle ARFCN

[:SENSe] :CHANnel :ARFCn | RFChannel :MIDDLE

Set the analyzer to the frequency of the middle ARFCN (Absolute RF Channel Number) of the selected radio band.

Factory Preset: 38 for E-GSM

63 for P-GSM

28 for R-GSM

699 for DCS1800

661 for PCS1900

276 for GSM450

323 for GSM480

474 for GSM 700

189 for GSM850

Remarks: You must be in the GSM, EDGE mode to use this command. Use INSTRUMENT:SElect to set the mode.
Global to the current mode.

Front Panel

Access: **FREQUENCY Channel, BMT Freq**

Select the Highest ARFCN

```
[ :SENSE ] :CHANnel :ARFCn | RFCHannel :TOP
```

Set the analyzer to the frequency of the highest ARFCN (Absolute RF Channel Number) of the selected radio band.

Factory Preset: 124 for E-GSM

124 for P-GSM

124 for R-GSM

885 for DCS1800

810 for PCS1900

293 for GSM450

340 for GSM480

511 for GSM700

251 for GSM850

Remarks: You must be in the GSM, EDGE mode to use this command. Use INSTRument:SElect to set the mode.

Global to the current mode.

Front Panel

Access: **FREQUENCY Channel, BMT Freq**

Channel Burst Type

```
[ :SENSE ] :CHANnel :BURSt NORMal | SYNC | ACCess
```

```
[ :SENSE ] :CHANnel :BURSt?
```

Set the burst type that the analyzer will search for and to which it will sync. This only applies with normal burst selected.

NORMal: Traffic Channel (TCH) and Control Channel (CCH)

SYNC: Synchronization Channel (SCH)

ACCess: Random Access Channel (RACH)

Remarks: You must be in the GSM, EDGE mode to use this command. Use INSTRument:SElect to set the mode.

Global to the current mode.

Front Panel

Access: **FREQUENCY Channel, Burst Type**

Time Slot number

[:SENSe] :CHANnel :SLOT <integer>

[:SENSe] :CHANnel :SLOT?

Select the slot number that you want to measure.

In GSM mode the measurement frame is divided into the eight expected measurement timeslots.

Factory Preset: 0 for GSM, EDGE, PDC mode

1 for NADC mode

Range: 0 to 5 for PDC mode

1 to 6 for NADC mode

0 to 7 for GSM, EDGE mode

Remarks: You must be in GSM, EDGE, NADC, PDC mode to use this command. Use INSTRument:SElect to set the mode.

Front Panel

Access: **Mode Setup, Radio, Frequency Hopping Repetition Factor**

Time Slot Auto

[:SENSe] :CHANnel :SLOT :AUTO OFF | ON | 0 | 1

[:SENSe] :CHANnel :SLOT :AUTO?

Select auto or manual control for slot searching. The feature is only supported in external and frame trigger source modes. In external trigger mode when timeslot is set on, the demodulation measurement is made on the nth timeslot specified by the external trigger point + n timeslots, where n is the selected timeslot value 0 to 7. In frame trigger mode when timeslot is set on, then demodulation measurement is only made on the nth timeslot specified by bit 0 of frame reference burst + n timeslots, where n is the selected timeslot value 0 to 7 and where the frame reference burst is specified by Ref Burst and Ref TSC (Std) combination.

Factory Preset: ON, for NADC, PDC mode

OFF, for GSM, EDGE mode

Remarks: The command is only applicable for mobile station testing, device = MS.

You must be in GSM, EDGE, NADC, PDC mode to use this command. Use INSTRument:SElect to set the mode.

Training Sequence Code (TSC)

[:SENSe] :CHANnel:TSCode <integer>

[:SENSe] :CHANnel:TSCode?

Set the training sequence code to search for, with normal burst selected and TSC auto set to off.

Factory Preset: 0

Range: 0 to 7

Remarks: Global to the current mode.

You must be in the GSM, EDGE mode to use this command. Use INSTRument:SElect to set the mode.

Front Panel

Access: FREQUENCY Channel, TSC (Std)

Training Sequence Code (TSC) Auto

[:SENSe] :CHANnel:TSCode:AUTO OFF|ON|0|1

[:SENSe] :CHANnel:TSCode:AUTO?

Select auto or manual control for training sequence code (TSC) search. With auto on, the measurement is made on the first burst found to have one of the valid TSCs in the range 0 to 7 (i.e. normal bursts only). With auto off, the measurement is made on the 1st burst found to have the selected TSC.

Factory Preset: AUTO

Remarks: Global to the current mode.

You must be in the GSM, EDGE mode to use this command. Use INSTRument:SElect to set the mode.

Front Panel

Access: FREQUENCY Channel, TSC (Std)

Signal Corrections Commands

Correction for BTS RF Port External Attenuation

```
[ :SENSE]:CORRection:BTS[:RF]:LOSS <rel_power>
```

```
[ :SENSE]:CORRection:BTS[:RF]:LOSS?
```

Set equal to the external attenuation used when measuring base transmit stations.

Factory Preset: 0.0 dB

Range: -50 to 100.0 dB for GSM, EDGE
 -100.0 to 100.0 dB for cdma2000, W-CDMA

Default Unit: dB

Remarks: Global to the current mode.

You must be in the GSM, EDGE, cdma2000, W-CDMA mode to use this command. Use INSTRUMENT:SElect to set the mode.

Correction for Mobile Station RF Port External Attenuation

```
[ :SENSE]:CORRection:MS[:RF]:LOSS <rel_power>
```

```
[ :SENSE]:CORRection:MS[:RF]:LOSS?
```

Set the correction equal to the external attenuation used when measuring mobile stations.

Factory Preset: 0.0 dB

Range: -50 to 100.0 dB for cdmaOne, GSM, EDGE
 -100.0 to 100.0 dB for cdma2000, W-CDMA
 -50.0 to 50.0 dB for NADC, PDC

Default Unit: dB

Remarks: You must be in the cdmaOne, EDGE (w/GSM), cdma2000, W-CDMA, NADC or PDC mode to use this command. Use INSTRUMENT:SElect to set the mode.

Value is global to the current mode.

EDGE Error Vector Magnitude Measurement

Commands for querying the EDGE error vector magnitude measurement results and for setting to the default values are found in the “MEASure Group of Commands” on page 206. The equivalent front panel keys for the parameters described in the following commands, are found under the **Meas Setup** key, after the measurement has been selected from the **MEASURE** key menu.

EDGE Error Vector Magnitude—Average Count

```
[ :SENSe ] :EEVM:AVERAge:COUNT <integer>
```

```
[ :SENSe ] :EEVM:AVERAge:COUNT?
```

Sets the number of data acquisitions that will be averaged. After the specified number of average counts, the average mode (termination control) setting determines the average action.

Factory Preset: 10

Range: 1 to 10,000

Remarks: You must be in the EDGE(w/GSM) mode to use this command. Use INSTRument:SELEct to set the mode.

EDGE Error Vector Magnitude—Averaging State

```
[ :SENSe ] :EEVM:AVERAge[ :STATe ] OFF | ON | 0 | 1
```

```
[ :SENSe ] :EEVM:AVERAge[ :STATe ]?
```

Turn average on or off.

Factory Preset: ON

Remarks: You must be in the EDGE(w/GSM) mode to use this command. Use INSTRument:SELEct to set the mode.

EDGE Error Vector Magnitude—Averaging Termination Control

```
[ :SENSe ] :EEVM:AVERAge:TCONTRol EXPOnential | REPEat
```

```
[ :SENSe ] :EEVM:AVERAge:TCONTRol?
```

Select the type of termination control used to averaging. This determines the averaging action after the specified number of data acquisitions (average count) is reached.

EXPOnential – Each successive data acquisition after the average count is reached, is exponentially weighted and combined with the

existing average.

REPeat – After reaching the average count, the averaging is reset and a new average is started.

Factory Preset: EXPonential

Remarks: You must be in the EDGE(w/GSM) mode to use this command. Use INSTRument:SElect to set the mode.

EDGE Error Vector Magnitude—Burst Synchronization Source

[:SENSe] :EEVM:BSYNc :SOURce RFBurst | TSEQUence | NONE

[:SENSe] :EEVM:BSYNc :SOURce?

Select the method of synchronizing the measurement to the bursts.

RFBurst – The burst synchronization approximates the start and stop of the useful part of the burst without demodulation of the burst. This type of synchronization has a frequency lock range of up to 9 kHz and allows you to demodulate RF bursts that do not have a training sequence.

Training Sequence (TSEQUence) – The burst synchronization performs a demodulation of the burst and determines the start and stop of the useful part of the burst based on the midamble training sync sequence. This type of synchronization provides better noise immunity but has a smaller frequency lock range (~200 Hz).

None – The measurement is performed without searching burst.

Factory Preset: TSEQUence

Remarks: You must be in the EDGE(w/GSM) mode to use this command. Use INSTRument:SElect to set the mode.

EDGE Error Vector Magnitude—Droop Compensation

[:SENSe] :EEVM:DROop OFF | ON | 0 | 1

[:SENSe] :EEVM:DROop?

Turn droop compensation on or off. Droop compensation corrects amplitude variations across a burst. You may want to turn off this compensation so you can see the changes in the measured magnitude error. Droop can result from signal impairments like a power amplifier problem.

Factory Preset: ON

Range: OFF, ON

Remarks: You must be in the EDGE(w/GSM) mode to use this

command. Use INSTRument:SElect to set the mode.

EDGE Error Vector Magnitude—Activate Extreme Limits

```
[ :SENSe ]:EEVM:ELIMit OFF|ON|0|1
```

```
[ :SENSe ]:EEVM:ELIMit?
```

Turn EEVM extreme limits on or off. GSM 5.05 provides two sets of limits, called “Normal” and “Extreme”. Select “ON” to turn the extreme limits on. Select “OFF” to return limits to the “Normal” parameter after the “Extreme” limits have been selected.

Factory Preset: OFF

Range: OFF, ON

Remarks: You must be in the EDGE(w/GSM) mode to use this command. Use INSTRument:SElect to set the mode.

EDGE Error Vector Magnitude—Points/Symbol

```
[ :SENSe ]:EEVM:SDOTs OFF|ON|0|1
```

```
[ :SENSe ]:EEVM:SDOTs?
```

Activates or deactivates points/symbol dot display.

Factory Preset: ON

Range: OFF, ON

Remarks: You must be in the EDGE(w/GSM) mode to use this command. Use INSTRument:SElect to set the mode.

EDGE Error Vector Magnitude—Points/Symbol

```
[ :SENSe ]:EEVM:TRACe:SDOTs <integer>
```

```
[ :SENSe ]:EEVM:TRACe:SDOTs?
```

Selects the number of dots that will be displayed for each symbol.

Factory Preset: 5

Range: 1 to 5

Remarks: You must be in the EDGE(w/GSM) mode to use this command. Use INSTRument:SElect to set the mode.

EDGE Error Vector Magnitude—Trigger Source

```
[ :SENSE ] :EEVM:TRIGger:SOURce  
EXTernal[1] | EXTernal2 | FRAMe | IF | IMMEDIATE | RFBurst  
[ :SENSe ] :EEVM:TRIGger:SOURce?
```

Select the trigger source used to control the data acquisitions.

EXTernal 1 – front panel external trigger input

EXTernal 2 – rear panel external trigger input

IF – internal IF envelope (video) trigger

IMMEDIATE – the next data acquisition is immediately taken, capturing the signal asynchronously (also called free run)

FRAMe – internal frame trigger from front panel input

RFBurst – wideband RF burst envelope trigger that has automatic level control for periodic burst signals

Factory Preset: IMMEDIATE for BS

RFBurst for MS

Remarks: You must be in the EDGE(w/GSM) mode to use this command. Use INSTRUMENT:SElect to set the mode.

EDGE Output RF Spectrum Measurement

Commands for querying the EDGE output RF spectrum measurement results and for setting to the default values are found in the “[MEASure Group of Commands](#)” on page 206. The equivalent front panel keys for the parameters described in the following commands, are found under the **Meas Setup** key, after the **EDGE Output RF Spectrum** measurement has been selected from the **MEASURE** key menu.

EDGE Output RF Spectrum—Number of Bursts Averaged

```
[ :SENSe ] :EORFspectr :AVERAge :COUNT <integer>
```

```
[ :SENSe ] :EORFspectr :AVERAge :COUNT?
```

Set the number of bursts that will be averaged. For the output RF spectrum due to switching transients, it is more accurate to consider this the number of frames that are measured. After the specified number of bursts (average counts), the averaging mode (terminal control) setting determines the averaging action.

Factory Preset: 20

Range: 1 to 10,000

Remarks: You must be in the EDGE(w/GSM) mode to use this command. Use INSTRument:SElect to set the mode.

EDGE Output RF Spectrum—Fast Averaging

```
[ :SENSe ] :EORFspectr :AVERAge :FAST [ :STATe ] OFF | ON | 0 | 1
```

```
[ :SENSe ] :EORFspectr :AVERAge :FAST [ :STATe ]?
```

Make the measurement faster by using an averaging technique different from that defined by the standard. A valid average can be obtained by measuring the power in half the normal number of bursts by using 50% - 90% of the burst, 10% - 50% of the burst and excluding the midamble.

This faster averaging is only done when averaging is on and only the modulation results are being measured. If both modulation and switching transients results are being measured, then the measurement uses the default averaging.

Factory Preset: ON

Remarks: You must be in the EDGE(w/GSM) mode to use this command. Use INSTRument:SElect to set the mode.

EDGE Output RF Spectrum—Averaging Type for Modulation Spectrum

```
[ :SENSe]:EORFspectr:AVERAge:MODUlation:TYPE LOG|RMS
```

```
[ :SENSe]:EORFspectr:AVERAge:MODUlation:TYPE?
```

Select the type of averaging for measuring the modulation spectrum. This is an advanced control that normally does not need to be changed. Setting this to a value other than the factory default, may cause invalid measurement results.

LOG - The log of the power is averaged. (This is also known as video averaging.)

RMS - The power is averaged, providing the rms of the voltage.

Factory Preset: LOG

Remarks: You must be in the EDGE(w/GSM) mode to use this command. Use INSTRument:SElect to set the mode.

EDGE Output RF Spectrum—Averaging Control

```
[ :SENSe]:EORFspectr:AVERAge[ :STATe] OFF|ON|0|1
```

```
[ :SENSe]:EORFspectr:AVERAge[ :STATe]?
```

Turn averaging on or off.

Factory Preset: ON

Remarks: You must be in the EDGE(w/GSM) mode to use this command. Use INSTRument:SElect to set the mode.

EDGE Output RF Spectrum—Resolution BW for the Modulation Spectrum at the Carrier

```
[ :SENSe]:EORFspectr:BANDwidth|BWIDth[ :RESolution]  
:MODulation:CARRier <freq>
```

```
[ :SENSe]:EORFspectr:BANDwidth|BWIDth[ :RESolution]  
:MODulation:CARRier?
```

Selects the resolution bandwidth for measuring the carrier when measuring spectrum due to modulation and wideband noise.

This parameter is only used with the Standard or Short lists, and not with the Custom list.

Factory Preset: 30 kHz

Range: 1 kHz to 5 MHz

Default Unit: Hz

Remarks: You must be in the EDGE(w/GSM) mode to use this command. Use INSTRument:SElect to set the mode.

EDGE Output RF Spectrum—Resolution BW For Modulation At Close Offsets

```
[ :SENSe ] :EORFspectr :BANDwidth | BWIDth [ :RESolution ]  
:MODulation :OFFSet :CLOSE <freq>
```

```
[ :SENSe ] :EORFspectr :BANDwidth | BWIDth [ :RESolution ]  
:MODulation :OFFSet :CLOSE?
```

Set the resolution bandwidth used for the spectrum due to modulation part of the EORF measurement for offset frequencies less than 1800 kHz.

This parameter is only used with the Standard or Short lists, and not with the Custom list.

Factory Preset: 30 kHz

Range: 1 kHz to 5 MHz

Default Unit: Hz

Remarks: You must be in the EDGE(w/GSM) mode to use this command. Use INSTRument:SElect to set the mode.

EDGE Output RF Spectrum—Resolution BW for Modulation at Far Offsets

```
[ :SENSe ] :EORFspectr :BANDwidth | BWIDth [ :RESolution ]  
:MODulation :OFFSet :FAR <freq>
```

```
[ :SENSe ] :EORFspectr :BANDwidth | BWIDth [ :RESolution ]  
:MODulation :OFFSet :FAR?
```

Set the resolution bandwidth used for the spectrum due to modulation part of the EORF measurement for offset frequencies greater than or equal to 1800 kHz.

This parameter is only used with the Standard or Short lists, and not with the Custom list.

Factory Preset: 100 kHz

Range: 1 kHz to 5 MHz

Default Unit: Hz

Remarks: You must be in the EDGE(w/GSM) mode to use this command. Use INSTRument:SElect to set the mode.

EDGE Output RF Spectrum—Resolution BW for the Switching Transient Spectrum at the Carrier

```
[ :SENSE]:EORFspectr:BANDwidth|BWIDth[:RESolution]
:SWITChing:CARRier <freq>
```

```
[ :SENSE]:EORFspectr:BANDwidth|BWIDth[:RESolution]
:SWITChing:CARRier?
```

Selects the resolution bandwidth for the carrier when measuring spectrum due to switching transients.

This parameter is only used with the Standard or Short lists, and not with the Custom list.

Factory Preset: 300 kHz

Range: 1 kHz to 5 MHz

Default Unit: Hz

Remarks: You must be in the EDGE(w/GSM) mode to use this command. Use INSTRument:SElect to set the mode.

EDGE Output RF Spectrum—Resolution BW For Switching Transients At Close Offsets

```
[ :SENSE]:EORFspectr:BANDwidth|BWIDth[:RESolution]
:SWITChing:OFFSet:CLOSe <freq>
```

```
[ :SENSE]:EORFspectr:BANDwidth|BWIDth[:RESolution]
:SWITChing:OFFSet:CLOSe?
```

Set the resolution bandwidth used for the spectrum due to switching transients part of the EORF measurement for offset frequencies less than 1800 kHz.

This parameter is only used with the Standard or Short lists, and not with the Custom list.

Factory Preset: 30 kHz

Range: 1 kHz to 5 MHz

Default Unit: Hz

Remarks: You must be in the EDGE(w/GSM) mode to use this command. Use INSTRument:SElect to set the mode.

EDGE Output RF Spectrum—Resolution BW For Switching Transients At Far Offsets

```
[ :SENSE]:EORFspectr:BANDwidth|BWIDth[:RESolution]
:SWITChing:OFFSet:FAR <freq>
```

```
[ :SENSe ] :EORFspectr :BANDwidth | BWIDth [ :RESolution ]  
:SWITching :OFFSet :FAR?
```

Set the resolution bandwidth used for the spectrum due to switching transients part of the EORF measurement for offset frequencies greater than or equal to 1800 kHz.

This parameter is only used with the standard or short lists, and not with the custom list.

Factory Preset: 30 kHz

100 kHz

Range: 1 kHz to 5 MHz

Default Unit: Hz

Remarks: You must be in the EDGE(w/GSM) mode to use this command. Use INSTRument:SElect to set the mode.

EDGE Output RF Spectrum—Break Frequency

```
[ :SENSe ] :EORFspectr :BFrequency <freq>
```

```
[ :SENSe ] :EORFspectr :BFrequency?
```

LP: keep the ORFS meas tracking with this command.

Set the direct time break frequency. An FFT measurement method is used for offsets below this break frequency. The direct time measurement method is used for offsets above the break frequency. See the Making EDGE (with GSM) Measurement chapter for more information about these two methods.

Factory Preset: 600 kHz

Range: 0 kHz to 775 kHz

Default Unit: Hz

Remarks: You must be in the EDGE(w/GSM) mode to use this command. Use INSTRument:SElect to set the mode.

Front Panel

Access: Meas Setup, Advanced, Direct Time Break Freq

EDGE Output RF Spectrum—Define Custom Modulation Resolution Bandwidth List

```
[ :SENSe ] :EORFspectr :LIST :MODulation :BANDwidth | BWIDth  
<res bw> { , <res bw> }
```

```
[ :SENSe ] :EORFspectr :LIST :MODulation :BANDwidth | BWIDth?
```

Define the custom set of resolution bandwidths for the modulation spectrum part of the EORF measurement. The first bandwidth specified is for the carrier. Each resolution bandwidth in this list corresponds to an offset frequency in the modulation offset frequency list. The number of items in each of these lists needs to be the same.

Factory Preset: Same as standard list

Range: 1 kHz to 5 MHz

Default Unit: Hz

Remarks: This command is only valid if SENS:EORF:MEAS is set to multiple and the custom list type is selected with SENS:EORF:LIST:SEL CUST.

You must be in the EDGE(w/GSM) mode to use this command. Use INSTRument:SElect to set the mode.

EDGE Output RF Spectrum—Define Custom Modulation Offset Frequency List

```
[ :SENSe ]:EORFspectr:LIST:MODulation[ :FREQuency ]
<offset freq>{ ,<offset freq> }
```

```
[ :SENSe ]:EORFspectr:LIST:MODulation[ :FREQuency ]?
```

Define the custom set of offset frequencies at which the modulation spectrum part of the EORF measurement will be made. The first offset specified must be 0 Hz for the carrier. For each offset frequency specified, the power will be measured at both the lower and upper offsets. Up to 14 (+ the 0 Hz carrier frequency) offset frequencies may be defined.

Factory Preset: Same as standard list

Range: 10 kHz to 10 MHz

Default Unit: Hz

Remarks: This command is only valid if SENS:EORF:MEAS is set to multiple and the custom list type is selected with SENS:EORF:LIST:SEL CUST.

You must be in the EDGE(w/GSM) mode to use this command. Use INSTRument:SElect to set the mode.

EDGE Output RF Spectrum—Define Custom Modulation Level Offsets

```
[ :SENSe ]:EORFspectr:LIST:MODulation:LOFFset
<level>{ ,<level> }
```

[[:SENSe]:EORFspectr:LIST:MODulation:LOFFset?

Define the custom set of level offsets for the modulation spectrum part of the EORF measurement. This allows you to modify the standard limits by adding a delta amplitude value to them. The first level offset specified must be 0 dB for the carrier. Each level offset in this list corresponds to an offset frequency in the modulation offset frequency list. The number of items in each of these lists needs to be the same.

Example: `EORF:LIST:MOD:FREQ 0,300e3,1.3e6,2.0e6`

Sets custom offset freqs: 300 kHz, 1.3 MHz, 2 MHz

`EORF:LIST:MOD:BAND 30e3,30e3,30e3,100e3`

Sets corresponding RBWs: 30 kHz, 30 kHz, 100 kHz

`EORF:LIST:MOD:loffset 0,-5,3,5`

Assume the power level of the signal is -43 dBm, then the standard limits for these three offsets are: -42 dBc, -72 dBc, -75 dBc respectively. The loffset command adjusts these limits to: -47 (-42-5) dBc, -70 (-73+3) dBc, -70 (-75+5) dBc.

Factory Preset: 0 dB level offsets (limits remain the same as the standards)

Range: 0 to 50 dB

Default Unit: dB

Remarks: This command is only valid if SENS:EORF:MEAS is set to multiple and the custom list type is selected with SENS:EORF:LIST:SEL CUST.

You must be in the EDGE(w/GSM) mode to use this command. Use INSTRument:SElect to set the mode.

EDGE Output RF Spectrum—Offset Frequency List

[[:SENSe]:EORFspectr:LIST:SElect CUSTom|SHORT|STANDARD

[[:SENSe]:EORFspectr:LIST:SElect?

Select the list of settings that will be used to make the EORF measurement. This specifies standard or customized lists and short lists. The lists contain the offset frequencies (and bandwidths) that are used for the modulation spectrum and transient spectrum parts of the EORF measurement.

CUSTom - uses the four user-defined lists that specify:

- Offset frequencies for modulation spectrum measurement
- Corresponding resolution bandwidths for each of the modulation

offset frequencies

- Offset frequencies for switching transient spectrum measurement
- Corresponding resolution bandwidths for each of the switching transient offset frequencies

SHORT - a shortened list of the offset frequencies specified in the EDGE Standards. It uses two internal offset frequency lists, one for modulation spectrum and the other for switching transient spectrum. These offset frequencies cannot be changed, but the resolution bandwidths can be changed by other commands in the SENSe:EORFpctr subsystem.

STANdard - the complete list of the offset frequencies specified in the EDGE Standards, except for those offsets greater than 6 MHz. It uses two internal offset frequency lists, one for modulation spectrum and the other for switching transient spectrum. These offset frequencies cannot be changed, but the resolution bandwidths can be changed by other commands in the SENSe:EORFpctr subsystem.

Factory Preset: SHORT

Remarks: This command is only valid if SENS:EORF:MEAS is set to multiple.

If you change the number of custom offsets then the number of offset bandwidths, frequencies and level offsets must also be changed.

You must be in the EDGE(w/GSM) mode to use this command. Use INSTRument:SElect to set the mode.

EDGE Output RF Spectrum—Define Custom Switching Transient Resolution Bandwidth List

```
[ :SENSe ]:EORFspectr:LIST:SWITching:BANDwidth|BWIDth
<res bw>{ ,<res bw> }
```

```
[ :SENSe ]:EORFspectr:LIST:SWITching:BANDwidth|BWIDth?
```

Define the custom set of resolution bandwidths for the switching transient spectrum part of the EORF measurement. The first bandwidth specified is for the carrier. Each resolution bandwidth in this list corresponds to an offset frequency in the switching transient offset frequency list. The number of items in each of these lists needs to be the same.

Factory Preset: Same as standard list

Range: 1 kHz to 5 MHz

Default Unit: Hz

Remarks: This command is only valid if SENS:EORF:MEAS is set

to multiple and the custom list type is selected with
SENS:EORF:LIST:SEL CUST.

You must be in EDGE(w/GSM) mode to use this
command. Use INSTRument:SElect to set the mode.

EDGE Output RF Spectrum—Define Custom Switching Transient Offset Frequency List

```
[ :SENSe ] :EORFspectr:LIST:SWITChing[ :FREQuency ]  
<offset freq>{ ,<offset freq> }
```

```
[ :SENSe ] :EORFspectr:LIST:SWITChing[ :FREQuency ] ?
```

Define the custom set of offset frequencies at which the switching transient spectrum part of the EORF measurement will be made. The first offset specified must be 0 Hz, for the carrier. For each offset frequency specified, the power will be measured at both the lower and upper offsets. Up to 14 (+ the 0 Hz carrier frequency) offset frequencies may be defined.

Factory Preset: Same as standard list

Range: 10 kHz to 10 MHz

Default Unit: Hz

Remarks: This command is only valid if SENS:EORF:MEAS is set to multiple and the custom list type is selected with SENS:EORF:LIST:SEL CUST.

You must be in the EDGE(w/GSM) mode to use this
command. Use INSTRument:SElect to set the mode.

EDGE Output RF Spectrum—Define Custom Switching Transient Level Offsets

```
[ :SENSe ] :EORFspectr:LIST:SWITChing:LOFFset  
<level>{ ,<level> }
```

```
[ :SENSe ] :EORFspectr:LIST:SWITChing:LOFFset ?
```

Define the custom set of level offsets for the switching transient spectrum part of the EORF measurement. This allows you to modify the standard limits by adding a delta amplitude value to them. The first level offset specified must be 0 dB for the carrier. Each level offset in this list corresponds to an offset frequency in the modulation offset frequency list. The number of items in each of these lists needs to be the same.

Example: See the EORF:LIST:MOD:LOFF example above.

Factory Preset: 0 dB level offsets (limits remain the same as the standards)

Range: 0 to 50 dB

Default Unit: dB

Remarks: This command is only valid if SENS:EORF:MEAS is set to multiple and the custom list type is selected with SENS:EORF:LIST:SEL CUST.

You must be in EDGE(w/GSM) mode to use this command. Use INSTRument:SElect to set the mode.

EDGE Output RF Spectrum—Measure Offsets Measurement Method

```
[ :SENSe ]:EORFspectr:MEASure MULTiple|SINGLE
```

```
[ :SENSe ]:EORFspectr:MEASure?
```

Select the measurement method to be used.

MULTiple - the measurement is done at all offsets in the offset frequency list.

SINGLE - the measurement is done at only one offset as determined by the offset frequency setting. This allows detailed examination of the time-domain waveform at the specified offset frequency.

Factory Preset: MULTiple

Remarks: You must be in the EDGE(w/GSM) mode to use this command. Use INSTRument:SElect to set the mode.

EDGE Output RF Spectrum—Offset Frequency

```
[ :SENSe ]:EORFspectr:OFrequency <freq>
```

```
[ :SENSe ]:EORFspectr:OFrequency?
```

Set the offset frequency that is used to measure a single offset. This command is only valid if SENS:EORF:MEAS is set to single.

Factory Preset: 250 kHz

Range: -12.0 MHz to +12.0 MHz, step size: steps through the values in the selected offset frequency list.

Default Unit: Hz

Remarks: You must be in the EDGE(w/GSM) mode to use this command. Use INSTRument:SElect to set the mode.

EDGE Output RF Spectrum—Trigger Source

```
[ :SENSe ] :EORFspectr :TRIGger :SOURce  
EXTernal [ 1 ] | EXTernal2 | FRAME | IMMEDIATE | RFBURSt
```

```
[ :SENSe ] :EORFspectr :TRIGger :SOURce?
```

Select the trigger source used to control the data acquisitions.

EXTernal 1 - front panel external trigger input

EXTernal 2 - rear panel external trigger input

FRAME - uses the internal frame timer, which has been synchronized to the selected burst sync

IMMEDIATE - the next data acquisition is immediately taken, capturing the signal asynchronously (also called free run)

RFBURSt - wideband RF burst envelope trigger that has automatic level control for periodic burst signals

Factory Preset: RFBURSt

Remarks: You must be in the EDGE(w/GSM) mode to use this command. Use INSTRument:SELEct to set the mode.

EDGE Output RF Spectrum—Measurement Type

```
[ :SENSe ] :EORFspectr :TYPE  
MODulation | MSWitching | SWITching | FFModulation
```

```
[ :SENSe ] :EORFspectr :TYPE?
```

Select the measurement type.

MODulation - only the modulation spectrum is measured.

MSWitching (Modulation & Switching) - both modulation and switching transient spectrums are measured.

SWITching - only the switching transient spectrum is measured.

FFModulation- full frame modulation improves measurement speed by acquiring a full frame of data prior to performing the FFT calculation. FFTModulation can only be used if all slots in the transmitted frame are active.

Factory Preset: MODulation

Remarks: You must be in the GSM, EDGE mode to use this command. Use INSTRument:SELEct to set the mode.

History: Version A.05.00

EDGE Output RF Spectrum—Select Modulation Method

```
[ :SENSE]:EORFspectr:TYPE:MODulation[:METHOD] DIScrete|SWEep  
[:SENSE]:EORFspectr:TYPE:MODulation[:METHOD]?
```

Selects discrete or sweep modulation method.

Discrete - Measures RF output spectrum at preset frequency offsets. Results are returned in tabular form.

Sweep - Measures output RF spectrum from -1.8 MHz to +1.8 MHz offset in approximately 10 kHz steps. Results are returned as a trace.

Remarks: You must be in the EDGE(w/GSM), GSM mode to use this command. Use INSTRUMENT:SElect to set the mode.

EDGE Power vs. Time (Burst Power) Measurement

Commands for querying the power versus time measurement results and for setting to the default values are found in the “MEASure Group of Commands” on page 206. The equivalent front panel keys for the parameters described in the following commands, are found under the **Meas Setup** key, after the **EDGE PwT** measurement has been selected from the **MEASURE** key menu.

EDGE Power vs. Time—Number of Bursts Averaged

```
[ :SENSe ] :EPVTime :AVERAge :COUNT <integer>
```

```
[ :SENSe ] :EPVTime :AVERAge :COUNT?
```

Set the number of bursts that will be averaged. After the specified number of bursts (average counts), the averaging mode (terminal control) setting determines the averaging action.

Factory Preset: 10

Range: 1 to 10,000

Remarks: You must be in the EDGE(w/GSM) mode to use this command. Use INSTRument:SElect to set the mode.

EDGE Power vs. Time—Averaging State

```
[ :SENSe ] :EPVTime :AVERAge [ :STATE ] OFF | ON | 0 | 1
```

```
[ :SENSe ] :EPVTime :AVERAge [ :STATE ]?
```

Turn averaging on or off.

Factory Preset: OFF

Remarks: You must be in the EDGE(w/GSM) mode to use this command. Use INSTRument:SElect to set the mode.

EDGE Power vs. Time—Averaging Mode

```
[ :SENSe ] :EPVTime :AVERAge :TCONTRol EXPonential | REPeat
```

```
[ :SENSe ] :EPVTime :AVERAge :TCONTRol?
```

Select the type of termination control used for the averaging function. This specifies the averaging action after the specified number of bursts (average count) is reached.

EXPonential - Each successive data acquisition after the average count is reached is exponentially weighted and combined with the existing average.

REPeat - After reaching the average count, the averaging is reset and a new average is started.

Factory Preset: EXPOnential

Remarks: You must be in the EDGE(w/GSM) mode to use this command. Use INSTRument:SElect to set the mode.

EDGE Power vs. Time—Averaging Type

```
[ :SENSE]:EPVTime:AVERAge:TYPE
LOG|MAXimum|MINimum|MXMinimum|RMS
```

```
[ :SENSE]:EPVTime:AVERAge:TYPE?
```

Select the type of averaging to be performed.

LOG - The log of the power is averaged. (This is also known as video averaging.)

MAXimum - The maximum values are retained.

MINimum - The minimum values are retained.

MXMinimum - Both the maximum and the minimum values are retained.

RMS - The power is averaged, providing the rms of the voltage.

Factory Preset: RMS

Remarks: You must be in the EDGE(w/GSM) mode to use this command. Use INSTRument:SElect to set the mode.

EDGE Power vs. Time—Resolution BW

```
[ :SENSE]:EPVTime:BANDwidth|BWIDth[:RESolution] <freq>
```

```
[ :SENSE]:EPVTime:BANDwidth|BWIDth[:RESolution]?
```

Set the resolution BW. This is an advanced control that normally does not need to be changed. Setting this to a value other than the factory default, may cause invalid measurement results.

Factory Preset: 500 kHz

Range: 1 kHz to 5 MHz

Default Unit: Hz

Remarks: You must be in the EDGE(w/GSM) mode to use this command. Use INSTRument:SElect to set the mode.

EDGE Power vs. Time—RBW Filter Type

```
[ :SENSe ]:EPVTime:BAWdwidth|BWIDth[:RESolution]:TYPE  
FLATtop|GAUSSian
```

```
[ :SENSe ]:EPVTime:BAWdwidth|BWIDth[:RESolution]:TYPE?
```

Select the type of resolution BW filter. This is an advanced control that normally does not need to be changed. Setting this to a value other than the factory default, may cause invalid measurement results.

FLATtop - a filter with a flat amplitude response, which provides the best amplitude accuracy.

GAUSSian - a filter with Gaussian characteristics, which provides the best pulse response.

Factory Preset: GAUSSian

Remarks: You must be in the EDGE(w/GSM) mode to use this command. Use INSTRument:SElect to set the mode.

EDGE Power vs. Time—Burst Synchronization Source

```
[ :SENSe ]:EPVTime:BSYNc:SOURce RFBurst|TSEquence
```

```
[ :SENSe ]:EPVTime:BSYNc:SOURce?
```

Select the method of synchronizing the measurement to the EDGE bursts.

RFBurst - the RF burst sync approximates the start and stop of the useful part of the burst without digital demodulation of the burst.

TSEquence - the training sequence burst sync performs a demodulation of the burst and determines the start and stop of the useful part of the burst based on the midamble training sequence.

Factory Preset: TSEquence

Remarks: You must be in the EDGE(w/GSM) mode to use this command. Use INSTRument:SElect to set the mode.

EDGE Power vs. Time—Limit Line Mask Display

```
[ :SENSe ]:EPVTime:LIMit:MASK OFF|ON|0|1
```

```
[ :SENSe ]:EPVTime:LIMit:MASK?
```

Show or hide the limit mask. Does not affect limit pass/fail calculation.

Same as :DISPlay:EPVTime:LIMit:MASK. The sense version was added to be compatible/consistent with ESA.

Factory Preset: ON

Range: ON/OFF
Remarks: You must be in GSM mode to use this command. Use INSTRument:SElect to set the mode.

EDGE Power vs. Time—Lower Mask Absolute Amplitude Levels

```
[ :SENSe ] :EPVTime:MASK:LIST:LOWer:ABSolute <power>{ ,<power>}
[ :SENSe ] :EPVTime:MASK:LIST:LOWer:ABSolute?
```

Enter a power level for any of your mask line segments that require an absolute minimum power limit in addition to its relative limit. Each time a measurement is made the Ref Level is determined. (This is the power level of the useful part of the burst, or midway between the upper/lower masks). Remember, as the power of the Ref Level changes, all of the relative mask power levels will change by the same amount.

Each relative limit is then compared to the Ref Level and an equivalent absolute power level is calculated. This power level is compared to the specified absolute limit for each line segment. If this calculated relative limit is lower than the absolute limit you've specified, then the value of the absolute limit is used for this segment. Therefore, if the absolute limit is set to a very low value (–200 dBm), the calculated value of the reference limit will never be lower, and the specified relative limit will always be used for that segment. See [Figure 4-4 on page 267](#).

Every time point you defined with PVT:MASK:LOW:TIME must have a power value defined in the same order. You can put a comma in the SCPI command as a place holder for any points where an absolute power is not specified, and that segment will then use the default value.

Factory Preset: Selected EDGE standard

Range: –200 dBm to +100 dBm

Default Unit: dBm

Remarks: You must be in EDGE(w/GSM) mode to use this command. Use INSTRument:SElect to set the mode.

EDGE Power vs. Time—Lower Mask Points

```
[ :SENSe ] :EPVTime:MASK:LIST:LOWer:POINTs?
```

Query the number of elements in the lower mask. This value is determined by the number of time points entered using

```
[ :SENSe ] :EPVTime:MASK:LIST:LOWer:TIME.
```

Range: integer, 1 to 25

Remarks: You must be in EDGE(w/GSM) mode to use this

command. Use INSTRument:SElect to set the mode.

EDGE Power vs. Time—Lower Mask Relative Amplitude Levels

```
[ :SENSe ] :EPVTime :MASK :LIST :LOWer :RELative  
<rel_power> { , <rel_power> }
```

```
[ :SENSe ] :EPVTime :MASK :LIST :LOWer :RELative ?
```

Enter the relative power level for each horizontal line segment in the lower limit mask. There should be a power level for each time point entered using [:SENSe] :EPVTime :MASK :LIST :LOWer :TIME, and they must be entered in the same order. These power levels are all relative to the defined Reference Power Level (the average power in the useful part of the data).

Any portion of the signal that has no limit line segment defined for it, will default to a very low limit (–100 dB relative to the reference power). This will keep the measurement from indicating a failure for that portion of the data.

Factory Preset: Selected EDGE standard

Range: +200 dB to –100 dB, relative to the reference power

Default Unit: dB

Remarks: You must be in EDGE(w/GSM) mode to use this command. Use INSTRument:SElect to set the mode.

EDGE Power vs. Time—Lower Mask Time Points

```
[ :SENSe ] :EPVTime :MASK :LIST :LOWer :TIME <seconds> { , <seconds> }
```

```
[ :SENSe ] :EPVTime :MASK :LIST :LOWer :TIME ?
```

Enter the time points that define the horizontal line segments of the lower limit. A reference point designated “ t_0 ” is at the center of the useful data (usually the center of the burst). Each line segment to the right of the t_0 reference point is designated as a positive time value and each segment to the left of t_0 is a negative time value.

First enter positive values in sequence starting from t_0 , then negative values in sequence starting from t_0 . See [Figure 4-4 on page 267](#) and the [:SENSe] :EPVT:MASK:LIST:UPPER:TIME example below it. (This is an upper mask example, but they work the same.)

We recommend that you select a large time value for your first and last mask points (e.g. –1 and +1 second). This guarantees that you’ve defined a limit for all the measured data. (See Mask Segments 4 and 9 in the [Table on page 268](#) for an example.)

Factory Preset: Selected EDGE standard

Range: –1s to +1s, referenced to t_0 at the center of the useful data (burst center)
 1 to 25 time points in a mask

Default Unit: seconds

Remarks: You must be in the EDGE(w/GSM) mode to use this command. Use INSTRUMENT:SELEct to set the mode.

EDGE Power vs. Time—Custom Limit Masks

`[:SENSE]:EPVTime:MASK:SELEct STANdard|CUSTom`

`[:SENSE]:EPVTime:MASK:SELEct?`

Select standard masks or user-defined custom masks to compare you measured data against.

Factory Preset: STANdard

Remarks: You must be in EDGE(w/GSM) mode to use this command. Use INSTRUMENT:SELEct to set the mode.

EDGE Power vs. Time—Upper Mask Absolute Amplitude Levels

`[:SENSE]:EPVTime:MASK:LIST:UPPER:ABSolute <power>{ ,<power> }`

`[:SENSE]:EPVTime:MASK:LIST:UPPER:ABSolute?`

Enter a power level for any of your mask line segments that require an absolute minimum power limit in addition to its relative limit. Each time a measurement is made the Ref Level is determined. (This is the power level of the useful part of the burst, or midway between the upper/lower masks). Remember, as the power of the Ref Level changes, all of the relative mask power levels will change by the same amount.

Each relative limit is then compared to the Ref Level and an equivalent absolute power level is calculated. This power level is compared to the specified absolute limit for each line segment. If this calculated relative limit is lower than the absolute limit you've specified, then the value of the absolute limit is used for this segment. Therefore, if the absolute limit is set to a very low value (–200 dBm), the calculated value of the reference limit will never be lower, and the specified relative limit will always be used for that segment. See [Figure 4-4 on page 267](#).

Every time point you defined with PVT:MASK:LOW:TIME must have a power value defined in the same order. You can put a comma in the SCPI command as a place holder for any points where an absolute power is not specified, and that segment will then use the default value.

Example: `EPVT:MASK:LIST:UPP:ABS -200, -200, -58, -200, -200, -200, -200, -58, -200`

Factory Preset: Selected EDGE standard

Range: -200 dBm to +100 dBm

Default Unit: dBm

Remarks: You must be in EDGE(w/GSM) mode to use this command. Use INSTRument:SElect to set the mode.

EDGE Power vs. Time—Upper Mask Points

`[:SENSe] :EPVTime:MASK:LIST:UPPer:POINTs?`

Query the number of elements in the upper mask. This value is determined by the number of time points entered using

`[:SENSe] :EPVTime:MASK:LIST:UPPer:TIME.`

Range: integer, 1 to 25

Remarks: You must be in EDGE(w/GSM) mode to use this command. Use INSTRument:SElect to set the mode.

EDGE Power vs. Time—Upper Mask Relative Amplitude Levels

`[:SENSe] :EPVTime:MASK:LIST:UPPer:RELative <rel_power>{ ,<rel_power> }`

`[:SENSe] :EPVTime:MASK:LIST:UPPer:RELative?`

Enter the relative power level for each horizontal line segment in the upper limit mask. There should be a power level for each time point entered using `[:SENSe] :EPVTime:MASK:LIST:UPPer:TIME`, and they must be entered in the same order. These power levels are all relative to the defined Reference Power Level (the average power in the useful part of the data). See [Figure 4-4 on page 267](#).

Example: `EPVT:MASK:LIST:UPP:REL 4, -32, -48, 100, 4, 7, -25, -43, 100`

Factory Preset: Selected EDGE standard

Range: 200 dB to -100 dB, relative to the reference power

Default Unit: dB

Remarks: You must be in EDGE(w/GSM) mode to use this command. Use INSTRument:SElect to set the mode.

EDGE Power vs. Time—Upper Mask Time Points

```
[ :SENSe ]:EPVTime:MASK:LIST:UPPER:TIME <seconds>{ ,<seconds>}
[ :SENSe ]:EPVTime:MASK:LIST:UPPER:TIME?
```

Enter the time points that define the horizontal line segments of the upper limit. A reference point designated “ t_0 ” is at the center of the useful data (usually the center of the burst). Each line segment to the right of the t_0 reference point is designated as a positive value and each segment to the left of t_0 is a negative value.

First enter positive values in sequence starting from t_0 , then the negative values in sequence starting from t_0 . See [Figure 4-4 on page 267](#) and the `EPVT:MASK:LIST:UPPER:TIME` example below it.

We recommend that you select a large time value for your first and last mask points (e.g. -1 and +1 second). This guarantees that you’ve defined a limit for all the measured data. (See Mask Segments 4 and 9 in the [Table on page 268](#) for an example.

Figure 4-4 Custom Upper Limit Mask Example

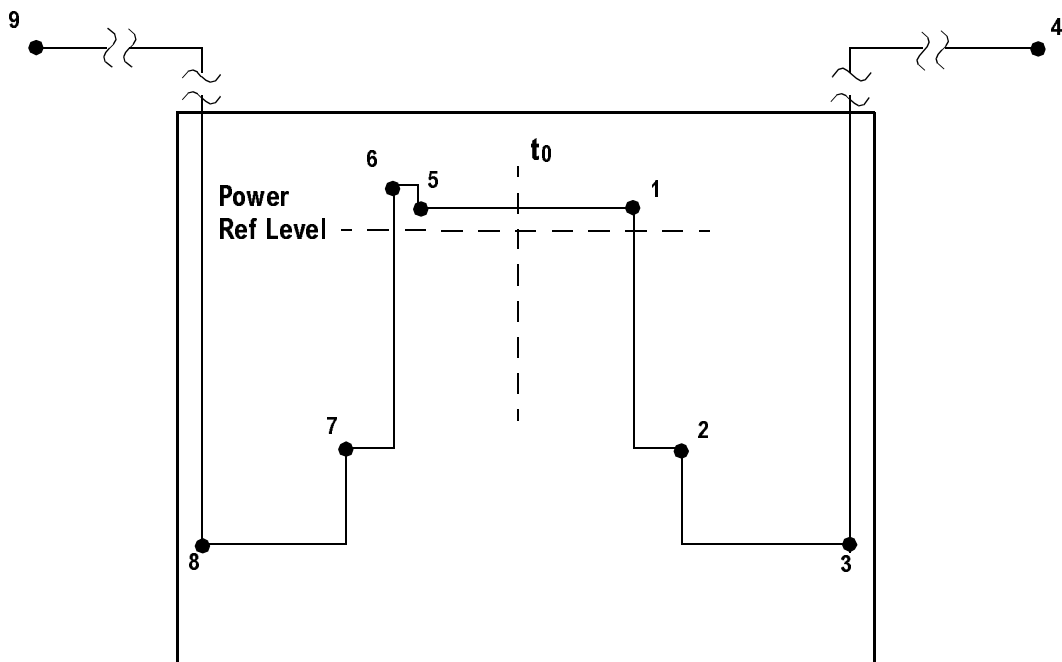

Entered Value for each Time Segment	Absolute Time Value	Relative Power (example (with Ref Level = -12 dBm))		Entered Absolute Power (dBm)	Segment Number
		Entered Relative Power	Equivalent Absolute Power		
280.0e-6	280 μ s	+4 dBc	-8 dBm	-200 dBm	1
15.0e-6	295 μ s	-32 dBc	-44 dBm	-200 dBm	2
450.0e-6	745 μ s	-48 dBc	-60 dBm ^a	-58 dBm ^a	3
1	>1 sec	+100 dBc	+112 dBm	-200 dBm	4
-270.0e-6	-270 μ s	+4 dBc	-8 dBm	-200 dBm	5
-10.0e-6	-280 μ s	+7 dBc	-5 dBm	-200 dBm	6
-20.0e-6	-300 μ s	-25 dBc	-37 dBm	-200 dBm	7
-450e-6	-750 μ s	-43 dBc	-55 dBm	-58 dBm	8
-1	<-1 sec	+100 dBc	+112 dBm	-200 dBm	9

- a. Notice that this segment, with this value of Ref Level, has a calculated relative level of -60 dBm. This is lower than the specified absolute level of -58 dBm, so the -58 dBm value will be used as the test limit for the segment.

Example: `EPVT:MASK:LIST:UPP:TIME 280e-6, 15e-6, 1, -270e-6, -10e-6, -20e-6, -1`

Factory Preset: Selected EDGE standard

Range: -1s to +1s, referenced to t_0 at the center of the useful data (burst center)

1 to 25 time points in a mask

Default Unit: seconds

Remarks: You must be in the EDGE(w/GSM) mode to use this command. Use INSTRUMENT:SELEct to set the mode.

EDGE Power vs Time - Select Power Control Level

Allows user to indicate the output power of the transmitter; in MS testing transmitter output power level will affect the mask. The appropriate power level for measuring the device under test will correspond with the transmitter power control level setting.

`[:SENSe] :EPVTime :PCLevel <integer>`

`[:SENSe] :EPVTime :PCLevel?`

Range: 0 to 40

Remarks: You must be in the power vs. time measurement in GSM or EDGE(w/GSM) mode to use this command. Use INSTRument:SElect to set the mode

Front Panel Access: **Meas Setup, More (1 of 2), Pwr Cntrl Lvl.**

History: Version A.05.00

EDGE Power vs. Time—Sweep Time

```
[ :SENSe ]:EPVTime:SWEep:TIME <integer>
```

```
[ :SENSe ]:EPVTime:SWEep:TIME?
```

Set the number of slots which are used in each data acquisition. Each slot is approximately equal to 570 ms. The measurement is made for a small additional amount of time (about 130 μ s) in order to view the burst edges.

Factory Preset: 1

Range: 1 to 50 (for resolution BW = 500 kHz)

Remarks: You must be in the EDGE(w/GSM) mode to use this command. Use INSTRument:SElect to set the mode.

EDGE Power vs. Time—Trigger Source

```
[ :SENSe ]:EPVTime:TRIGger:SOURce EXTernal[1] | EXTernal2  
| FRAMe | IF | IMMEDIATE | RFBurst
```

```
[ :SENSe ]:EPVTime:TRIGger:SOURce?
```

Select the trigger source used to control the data acquisitions.

EXTernal 1 - front panel external trigger input

EXTernal 2 - rear panel external trigger input

FRAMe - uses the internal frame timer, which has been synchronized to the selected burst sync.

IF - internal IF envelope (video) trigger

IMMEDIATE - the next data acquisition is immediately taken, capturing the signal asynchronously (also called Free Run).

RFBurst - wideband RF burst envelope trigger that has automatic level control for periodic burst signals.

Factory Preset: RFBurst

Remarks: You must be in the EDGE(w/GSM) mode to use this

command. Use **INSTRument:SElect** to set the mode.

EDGE Transmit Band Spurs Measurement

Commands for querying the EDGE transmit band spurs measurement results and for setting to the default values are found in the “[MEASure Group of Commands](#)” on page 206. The equivalent front panel keys for the parameters described in the following commands, are found under the **Meas Setup** key, after the **EDGE TxBand Spur** measurement has been selected from the **MEASURE** key menu.

Transmit Band Spurs—Average Count [VSA-E] [PSA-E]

```
[ :SENSe ] : ETSPur : AVERAge : COUNT <integer>
```

```
[ :SENSe ] : ETSPur : AVERAge : COUNT ?
```

Set the number of data acquisitions that will be averaged. After the specified number of average counts, the averaging mode (terminal control) setting determines the averaging action.

Factory Preset: 30

Range: 1 to 10,000

Remarks: You must be in the EDGE(w/GSM) mode to use this command. Use INSTRument:SElect to set the mode.

Transmit Band Spurs—Averaging State

```
[ :SENSe ] : ETSPur : AVERAge [ :STATe ] OFF | ON | 0 | 1
```

```
[ :SENSe ] : ETSPur : AVERAge [ :STATe ] ?
```

Turn averaging on or off.

Factory Preset: ON

Remarks: You must be in the EDGE(w/GSM) mode to use this command. Use INSTRument:SElect to set the mode.

Transmit Band Spurs—Averaging Termination Control

```
[ :SENSe ] : ETSPur : AVERAge : TCONTrOl EXPOnentiaL | REPeat
```

```
[ :SENSe ] : ETSPur : AVERAge : TCONTrOl ?
```

Select the type of termination control used for the averaging function. This determines the averaging action after the specified number of data acquisitions (average count) is reached.

EXPOnentiaL - Each successive data acquisition after the average count is reached, is exponentially weighted and combined with the existing average.

REPeat - After reaching the average count, the averaging is reset

and a new average is started.

Factory Preset: REPeat

Remarks: You must be in the EDGE(w/GSM) mode to use this command. Use INSTRument:SElect to set the mode.

Transmit Band Spurs—Averaging Type

```
[ :SENSe ] :ETSPur :AVERage :TYPE LOG | MAXimum | RMS
```

```
[ :SENSe ] :ETSPur :AVERage :TYPE?
```

Select the type of averaging.

LOG - The log of the power is averaged. (This is also known as video averaging.)

MAXimum - The maximum values are retained.

RMS - The power is averaged, providing the rms of the voltage.

Factory Preset: MAXimum

Remarks: You must be in the EDGE(w/GSM) mode to use this command. Use INSTRument:SElect to set the mode.

Transmit Band Spurs—Type

```
[ :SENSe ] :ETSPur :TYPE EXAMine | FULL
```

```
[ :SENSe ] :ETSPur :TYPE?
```

Select the measurement type.

EXAMine - measures spurs in all the valid segments and then displays the segment that has the worst spur

FULL - continuously measures the spurs in all the valid segments

Factory Preset: FULL

Remarks: You must be in the EDGE(w/GSM) mode to use this command. Use INSTRument:SElect to set the mode.

Select the Input Signal

```
[ :SENSE]:FEED RF|AREference|IFAlign
```

```
[ :SENSE]:FEED?
```

Selects the input signal. The default input signal is taken from the front panel RF input port. For calibration and testing purposes the input signal can be taken from an internal 321.4 MHz IF alignment signal or an internal 50 MHz amplitude reference source.

RF selects the signal from the front panel RF INPUT port.

AREference selects the internal 50 MHz amplitude reference signal.

IFAlign selects the internal, 321.4 MHz, IF alignment signal.

Factory Preset: RF

Front Panel

Access: **Input, Input Port**

Output RF Spectrum Measurement

Commands for querying the output RF spectrum measurement results and for setting to the default values are found in the “[MEASure Group of Commands](#)” on page 206. The equivalent front panel keys for the parameters described in the following commands, are found under the **Meas Setup** key, after the **GMSK Output RF Spectrum** measurement has been selected from the **MEASURE** key menu.

Output RF Spectrum—Number of Bursts Averaged

```
[ :SENSe ]:ORFSpectrum:AVERAge:COUNT <integer>
```

```
[ :SENSe ]:ORFSpectrum:AVERAge:COUNT?
```

Set the number of bursts that will be averaged. For the output RF spectrum due to switching transients, it is more accurate to consider this the number of frames that are measured. After the specified number of bursts (average counts), the averaging mode (terminal control) setting determines the averaging action.

Factory Preset: 15

Range: 1 to 10,000

Remarks: You must be in the GSM, EDGE mode to use this command. Use **INSTRument:SElect** to set the mode.

Output RF Spectrum—Fast Averaging

```
[ :SENSe ]:ORFSpectrum:AVERAge:FAST[ :STATe ] OFF|ON|0|1
```

```
[ :SENSe ]:ORFSpectrum:AVERAge:FAST[ :STATe ]?
```

Make the measurement faster by using an averaging technique different from that defined by the standard. A valid average can be obtained by measuring the power in half the normal number of bursts by using 50% - 90% of the burst, 10% - 50% of the burst and excluding the midamble.

This faster averaging is only done when averaging is on and only the modulation results are being measured. If both modulation and switching transients results are being measured, then the measurement uses the default averaging.

Factory Preset: ON

Remarks: You must be in the GSM, EDGE mode to use this command. Use **INSTRument:SElect** to set the mode.

Output RF Spectrum—Averaging Type for Modulation Spectrum

```
[ :SENSE]:ORFSpectrum:AVERage:MODulation:TYPE LOG|RMS
```

```
[ :SENSE]:ORFSpectrum:AVERage:MODulation:TYPE?
```

Select the type of averaging for measuring the modulation spectrum. This is an advanced control that normally does not need to be changed. Setting this to a value other than the factory default, may cause invalid measurement results.

LOG - The log of the power is averaged. (This is also known as video averaging.)

RMS - The power is averaged, providing the rms of the voltage.

Factory Preset: LOG

Remarks: You must be in the GSM, EDGE mode to use this command. Use INSTRUMENT:SELEct to set the mode.

Output RF Spectrum—Averaging Control

```
[ :SENSE]:ORFSpectrum:AVERage[:STATE] OFF|ON|0|1
```

```
[ :SENSE]:ORFSpectrum:AVERage[:STATE]?
```

Turn averaging on or off.

Factory Preset: ON

Remarks: You must be in the GSM, EDGE mode to use this command. Use INSTRUMENT:SELEct to set the mode.

Output RF Spectrum—Averaging Type for Switching Transient Spectrum Query

```
[ :SENSE]:ORFSpectrum:AVERage:SWITching:TYPE?
```

Queries the type of averaging for measuring the switching transient spectrum.

Factory Preset: MAXP (maximum peak power)

Remarks: You must be in the GSM, EDGE mode to use this command. Use INSTRUMENT:SELEct to set the mode.

History: Query only format adopted for version A.05.00.

Output RF Spectrum—Resolution BW for the Modulation Spectrum at the Carrier

```
[ :SENSe ]:ORFSpectrum:BANDwidth|BWIDth[:RESolution]  
:MODulation:CARRier <freq>
```

```
[ :SENSe ]:ORFSpectrum:BANDwidth|BWIDth[:RESolution]  
:MODulation:CARRier?
```

Selects the resolution bandwidth for measuring the carrier when measuring spectrum due to modulation and wideband noise.

This parameter is only used with the Standard or Short lists, and not with the Custom list.

Factory Preset: 30 kHz

Range: 1 kHz to 5 MHz

Default Unit: Hz

Remarks: You must be in the GSM, EDGE mode to use this command. Use INSTRUMENT:SElect to set the mode.

Output RF Spectrum—Resolution BW For Modulation At Close Offsets

```
[ :SENSe ]:ORFSpectrum:BANDwidth|BWIDth[:RESolution]  
:MODulation:OFFSet:CLOSe <freq>
```

```
[ :SENSe ]:ORFSpectrum:BANDwidth|BWIDth[:RESolution]  
:MODulation:OFFSet:CLOSe?
```

Set the resolution bandwidth used for the spectrum due to modulation part of the ORFS measurement for offset frequencies less than 1800 kHz.

This parameter is only used with the Standard or Short lists, and not with the Custom list.

Factory Preset: 30 kHz

Range: 1 kHz to 5 MHz

Default Unit: Hz

Remarks: You must be in the GSM, EDGE mode to use this command. Use INSTRUMENT:SElect to set the mode.

Output RF Spectrum—Resolution BW for Modulation at Far Offsets

```
[ :SENSe ]:ORFSpectrum:BANDwidth|BWIDth[:RESolution]  
:MODulation:OFFSet:FAR <freq>
```

```
[ :SENSE]:ORFSpectrum:BANDwidth|BWIDth[:RESolution]
:MODulation:OFFSet:FAR?
```

Set the resolution bandwidth used for the spectrum due to modulation part of the ORFS measurement for offset frequencies greater than or equal to 1800 kHz.

Factory Preset: 100 kHz

Range: 1 kHz to 5 MHz

Default Unit: Hz

Remarks: You must be in the GSM, EDGE mode to use this command. Use INSTRument:SElect to set the mode.

Output RF Spectrum—Resolution BW for the Switching Transient Spectrum at the Carrier

```
[ :SENSE]:ORFSpectrum:BANDwidth|BWIDth[:RESolution]
:SWITching:CARRIER <freq>
```

```
[ :SENSE]:ORFSpectrum:BANDwidth|BWIDth[:RESolution]
:SWITching:CARRIER?
```

Selects the resolution bandwidth for the carrier when measuring spectrum due to switching transients.

This parameter is only used with the Standard or Short lists, and not with the Custom list.

Factory Preset: 300 kHz

Range: 1 kHz to 5 MHz

Default Unit: Hz

Remarks: You must be in the GSM, EDGE mode to use this command. Use INSTRument:SElect to set the mode.

Output RF Spectrum—Resolution BW For Switching Transients At Close Offsets

```
[ :SENSE]:ORFSpectrum:BANDwidth|BWIDth[:RESolution]
:SWITching:OFFSet:CLOSe <freq>
```

```
[ :SENSE]:ORFSpectrum:BANDwidth|BWIDth[:RESolution]
:SWITching:OFFSet:CLOSe?
```

Set the resolution bandwidth used for the spectrum due to switching transients part of the ORFS measurement for offset frequencies less than 1800 kHz.

This parameter is only used with the Standard or Short lists, and not

with the Custom list.

Factory Preset: 30 kHz

Range: 1 kHz to 5 MHz

Default Unit: Hz

Remarks: You must be in the GSM, EDGE mode to use this command. Use INSTRument:SElect to set the mode.

Output RF Spectrum—Resolution BW For Switching Transients At Far Offset

```
[ :SENSE]:ORFSpectrum:BANDwidth|BWIDth[:RESolution]
:SWITChing:OFFSet:FAR <freq>
```

```
[ :SENSE]:ORFSpectrum:BANDwidth|BWIDth[:RESolution]
:SWITChing:OFFSet:FAR?
```

Set the resolution bandwidth used for the spectrum due to switching transients part of the ORFS measurement for offset frequencies greater than or equal to 1800 kHz.

This parameter is only used with the standard or short lists, and not with the custom list.

Factory Preset: 30 kHz

Range: 1 kHz to 5 MHz

Default Unit: Hz

Remarks: You must be in the GSM, EDGE mode to use this command. Use INSTRument:SElect to set the mode.

Output RF Spectrum—Break Frequency

```
[ :SENSE]:ORFSpectrum:BFRequency <freq>
```

```
[ :SENSE]:ORFSpectrum:BFRequency?
```

Set the direct time break frequency. An FFT measurement method is used for offsets below this break frequency. The direct time measurement method is used for offsets above the break frequency. See the chapter on making measurements for more information about these two methods.

Factory Preset: 600 kHz

Range: 0 kHz to 775 kHz

Default Unit: Hz

Remarks: You must be in the GSM, EDGE mode to use this command. Use INSTRument:SElect to set the mode.

Front Panel

Access: Meas Setup, Advanced, Direct Time Break Freq

Output RF Spectrum—Define Custom Modulation Resolution Bandwidth List

```
[ :SENSE]:ORFSpectrum:LIST:MODulation:BANDwidth|BWIDth
<res bw>{,<res bw>}
```

```
[ :SENSe ]:ORFSpectrum:LIST:MODulation:Bandwidth|BWIDth?
```

Define the custom set of resolution bandwidths for the modulation spectrum part of the ORFS measurement. The first bandwidth specified is for the carrier. Each resolution bandwidth in this list corresponds to an offset frequency in the modulation offset frequency list. The number of items in each of these lists needs to be the same.

Factory Preset: Same as standard list

Range: 1 kHz to 5 MHz

Default Unit: Hz

Remarks: This command is only valid if SENS:ORFS:MEAS is set to multiple and the custom list type is selected with SENS:ORFS:LIST:SEL CUST.

You must be in the GSM, EDGE mode to use this command. Use INSTRument:SElect to set the mode.

Output RF Spectrum—Define Custom Modulation Offset Frequency List

```
[ :SENSe ]:ORFSpectrum:LIST:MODulation[:FREQUENCY]  
<offset freq>{,<offset freq>}
```

```
[ :SENSe ]:ORFSpectrum:LIST:MODulation[:FREQUENCY]?
```

Define the custom set of offset frequencies at which the modulation spectrum part of the ORFS measurement will be made. The first offset specified must be 0 Hz for the carrier. For each offset frequency specified, the power will be measured at both the lower and upper offsets. Up to 14 (+ the 0 Hz carrier frequency) offset frequencies may be defined.

Factory Preset: Same as standard list

Range: 10 kHz to 10 MHz

Default Unit: Hz

Remarks: This command is only valid if SENS:ORFS:MEAS is set to multiple and the custom list type is selected with SENS:ORFS:LIST:SEL CUST.

You must be in the GSM, EDGE mode to use this command. Use INSTRument:SElect to set the mode.

Output RF Spectrum—Define Custom Modulation Level Offsets

```
[ :SENSe ]:ORFSpectrum:LIST:MODulation:LOFFset  
<level>{,<level>}
```

[:SENSe]:ORFSpectrum:LIST:MODulation:LOFFset?

Define the custom set of level offsets for the modulation spectrum part of the ORFS measurement. This allows you to modify the standard limits by adding a delta amplitude value to them. The first level offset specified must be 0 dB for the carrier. Each level offset in this list corresponds to an offset frequency in the modulation offset frequency list. The number of items in each of these lists needs to be the same.

Example: `ORFS:LIST:MOD:FREQ 0,300e3,1.3e6,2.0e6`
 Sets custom offset freqs: 300 kHz, 1.3 MHz, 2 MHz

`ORFS:LIST:MOD:BAND 30e3,30e3,30e3,100e3`
 Sets corresponding RBWs: 30 kHz, 30 kHz, 100 kHz

`ORFS:LIST:MOD:loffset 0,-5,3,5`
 Assume the power level of the signal is -43 dBm, then the standard limits for these three offsets are: -42 dBc, -72 dBc, -75 dBc respectively. The loffset command adjusts these limits to: -47 (-42-5) dBc, -70 (-73+3) dBc, -70 (-75+5) dBc.

Factory Preset: 0 dB level offsets (limits remain the same as the standards)

Range: 0 to 50 dB

Default Unit: dB

Remarks: This command is only valid if SENS:ORFS:MEAS is set to multiple and the custom list type is selected with SENS:ORFS:LIST:SEL CUST.

You must be in the GSM, EDGE mode to use this command. Use INSTRument:SElect to set the mode.

Output RF Spectrum—Offset Frequency List

[:SENSe]:ORFSpectrum:LIST:SElect?

Select the list of settings that will be used to make the ORFS measurement. This specifies standard or customized lists and short lists. The lists contain the offset frequencies (and bandwidths) that are used for the modulation spectrum and transient spectrum parts of the ORFS measurement.

CUSTom - uses the four user-defined lists that specify:

- Offset frequencies for modulation spectrum measurement
- Corresponding resolution bandwidths for each of the modulation offset frequencies
- Offset frequencies for switching transient spectrum measurement

- Corresponding resolution bandwidths for each of the switching transient offset frequencies

SHORT - a shortened list of the offset frequencies specified in the GSM Standards. It uses two internal offset frequency lists, one for modulation spectrum and the other for switching transient spectrum. These offset frequencies cannot be changed, but the resolution bandwidths can be changed by other commands in the SENSe:ORFSpectrum subsystem.

STANdard - the complete list of the offset frequencies specified in the GSM Standards, except for those offsets greater than 6 MHz. It uses two internal offset frequency lists, one for modulation spectrum and the other for switching transient spectrum. These offset frequencies cannot be changed, but the resolution bandwidths can be changed by other commands in the SENSe:ORFSpectrum subsystem.

Factory Preset: SHORT

Remarks: This command is only valid if SENS:ORFS:MEAS is set to multiple.

If you change the number of custom offsets then the number of offset bandwidths, frequencies and level offsets must also be changed.

You must be in the GSM, EDGE mode to use this command. Use INSTRument:SELEct to set the mode.

Output RF Spectrum—Define Custom Switching Transient Resolution Bandwidth List

```
[ :SENSe ] :ORFSpectrum:LIST:SWITching:BANDwidth|BWIDth  
<res_bw> { , <res_bw> }
```

```
[ :SENSe ] :ORFSpectrum:LIST:SWITching:BANDwidth|BWIDth?
```

Define the custom set of resolution bandwidths for the switching transient spectrum part of the ORFS measurement. The first bandwidth specified is for the carrier. Each resolution bandwidth in this list corresponds to an offset frequency in the switching transient offset frequency list. The number of items in each of these lists needs to be the same.

Factory Preset: Same as standard list

Range: 1 kHz to 5 MHz

Default Unit: Hz

Remarks: This command is only valid if SENS:ORFS:MEAS is set to multiple and the custom list type is selected with

SENS:ORFS:LIST:SEL CUST.

You must be in GSM, EDGE mode to use this command.
Use INSTRument:SElect to set the mode.

Output RF Spectrum—Define Custom Switching Transient Offset Frequency List

```
[ :SENSe ]:ORFSpectrum:LIST:SWITChing[ :FREQuency ]
<offset_freq>{ ,<offset_freq> }
```

```
[ :SENSe ]:ORFSpectrum:LIST:SWITChing[ :FREQuency ]?
```

Define the custom set of offset frequencies at which the switching transient spectrum part of the ORFS measurement will be made. The first offset specified must be 0 Hz, for the carrier. For each offset frequency specified, the power will be measured at both the lower and upper offsets. Up to 14 (+ the 0 Hz carrier frequency) offset frequencies may be defined.

Factory Preset: Same as standard list

Range: 10 kHz to 10 MHz

Default Unit: Hz

Remarks: This command is only valid if SENS:ORFS:MEAS is set to multiple and the custom list type is selected with SENS:ORFS:LIST:SEL CUST.

You must be in the GSM, EDGE mode to use this command. Use INSTRument:SElect to set the mode.

Output RF Spectrum—Define Custom Switching Transient Level Offsets

```
[ :SENSe ]:ORFSpectrum:LIST:SWITChing:LOFFset
<level>{ ,<level> }
```

```
[ :SENSe ]:ORFSpectrum:LIST:SWITChing:LOFFset?
```

Define the custom set of level offsets for the switching transient spectrum part of the ORFS measurement. This allows you to modify the standard limits by adding a delta amplitude value to them. The first level offset specified must be 0 dB for the carrier. Each level offset in this list corresponds to an offset frequency in the modulation offset frequency list. The number of items in each of these lists needs to be the same.

Example: See the ORFS:LIST:MOD:LOFF example above.

Factory Preset: 0 dB level offsets (limits remain the same as the

standards)
Range: 0 to 50 dB
Default Unit: dB
Remarks: This command is only valid if SENS:ORFS:MEAS is set to multiple and the custom list type is selected with SENS:ORFS:LIST:SEL CUST.
You must be in GSM, EDGE mode to use this command. Use INSTRument:SElect to set the mode.

Output RF Spectrum—Measure Offsets Measurement Method

```
[ :SENSe ]:ORFSpectrum:MEASure MULTiple|SINGLE
```

```
[ :SENSe ]:ORFSpectrum:MEASure?
```

Select the measurement method to be used.

MULTiple - the measurement is done at all offsets in the offset frequency list.

SINGLE - the measurement is done at only one offset as determined by the offset frequency setting. This allows detailed examination of the time-domain waveform at the specified offset frequency.

Factory Preset: MULTiple

Remarks: You must be in the GSM, EDGE mode to use this command. Use INSTRument:SElect to set the mode.

Output RF Spectrum—Offset Frequency

```
[ :SENSe ]:ORFSpectrum:OFRequency <freq>
```

```
[ :SENSe ]:ORFSpectrum:OFRequency?
```

Set the offset frequency that is used to measure a single offset. This command is only valid if SENS:ORFS:MEAS is set to single.

Factory Preset: 250 kHz

Range: -12.0 MHz to +12.0 MHz, step size: steps through the values in the selected offset frequency list.

Default Unit: Hz

Remarks: You must be in the GSM, EDGE mode to use this command. Use INSTRument:SElect to set the mode.

Output RF Spectrum—Trigger Source

```
[ :SENSE]:ORFSpectrum:TRIGger:SOURce  
EXTErnal[1]|EXTErnal2|FRAMe|IMMediate|RFBurst
```

```
[ :SENSe]:ORFSpectrum:TRIGger:SOURce?
```

Select the trigger source used to control the data acquisitions.

EXTErnal 1 - front panel external trigger input

EXTErnal 2 - rear panel external trigger input

FRAMe - uses the internal frame timer, which has been synchronized to the selected burst sync

IMMediate - the next data acquisition is immediately taken, capturing the signal asynchronously (also called free run)

RFBurst - wideband RF burst envelope trigger that has automatic level control for periodic burst signals

Factory Preset: RFBurst if the RF Burst Hardware (option B7E) has been installed

EXTErnal if option B7E has not been installed

Remarks: You must be in the GSM, EDGE mode to use this command. Use INSTRument:SElect to set the mode.

Output RF Spectrum—Measurement Type

```
[ :SENSe]:ORFSpectrum:TYPE  
MODulation|MSWitching|SWITching|FFModulation
```

```
[ :SENSe]:ORFSpectrum:TYPE?
```

Select the measurement type.

MODulation - only the modulation spectrum is measured.

MSWitching (Modulation & Switching) - both modulation and switching transient spectrums are measured.

SWITching - only the switching transient spectrum is measured.

FFModulation- full frame modulation improves measurement speed by acquiring a full frame of data prior to performing the FFT calculation. FFTModulation can only be used if all slots in the transmitted frame are active.

Factory Preset: MODulation

Remarks: You must be in the GSM, EDGE mode to use this command. Use INSTRument:SElect to set the mode.

History: Version A.05.00

Output RF Spectrum—Select Modulation Method

```
[ :SENSe ]:ORFSpectrum:TYPE:MODulation[:METHOD]  
DIScrete | SWEEp
```

```
[ :SENSe ]:ORFSpectrum:TYPE:MODulation[:METHOD]?
```

Selects discrete or sweep modulation method.

Discrete - Measures RF output spectrum at preset frequency offsets. Results are returned in tabular form.

Sweep - Measures output RF spectrum from -1.8 MHz to +1.8 MHz offset in approximately 10 kHz steps. Results are returned as a trace.

Remarks: You must be in the EDGE(w/GSM) mode to use this command. Use INSTRument:SElect to set the mode.

Phase & Frequency Error Measurement

Commands for querying the phase and frequency error measurement results and for setting to the default values are found in the “[MEASure Group of Commands](#)” on page 206. The equivalent front panel keys for the parameters described in the following commands, are found under the **Meas Setup** key, after the **GMSK Phase & Freq** measurement has been selected from the **MEASURE** key menu.

Phase & Frequency Error—Number Of Bursts Averaged [VSA-E,G] [ESA-G] [PSA-E]

```
[ :SENSe]:PFError:AVERage:COUNT <integer>
```

```
[ :SENSe]:PFError:AVERage:COUNT?
```

Set the number of bursts that will be averaged. After the specified number of bursts (average counts), the averaging mode (terminal control) setting determines the averaging action.

Factory Preset: 15

Range: 1 to 1,000

Remarks: You must be in the GSM, EDGE mode to use this command. Use INSTRument:SElect to set the mode.

Phase & Frequency Error—Averaging State

```
[ :SENSe]:PFError:AVERage[:STATe] OFF|ON|0|1
```

```
[ :SENSe]:PFError:AVERage[:STATe]?
```

Turn averaging on or off.

Factory Preset: OFF

Remarks: You must be in the GSM, EDGE mode to use this command. Use INSTRument:SElect to set the mode.

Phase & Frequency Error—Averaging Mode

```
[ :SENSe]:PFError:AVERage:TCONtrol EXPonential|REPeat
```

```
[ :SENSe]:PFError:AVERage:TCONtrol?
```

Select the type of termination control used for the averaging function. This determines the averaging action after the specified number of bursts (average count) is reached.

EXPonential - Each successive data acquisition after the average count is reached, is exponentially weighted and combined with the existing average.

REPeat - After reaching the average count, the averaging is reset and a new average is started.

Factory Preset:

Remarks: You must be in the GSM, EDGE mode to use this command. Use INSTRument:SElect to set the mode.

Phase & Frequency Error—Averaging Type

```
[ :SENSe ] :PFERror :AVERage :TYPE MEAN|MAXimum
```

```
[ :SENSe ] :PFERror :AVERage :TYPE?
```

Select the type of averaging:

MEAN - the scalar results are averaged.

MAXimum - the maximum scalar results are retained.

Factory Preset: MAXimum.

Remarks: You must be in the GSM, EDGE mode to use this command. Use INSTRument:SElect to set the mode.

Phase & Frequency Error—Burst Synchronization

```
[ :SENSe ] :PFERror :BSYNc :SOURce  
EXTernal [ 1 ] | EXTernal 2 | NONE | RFBurst | TSEQence
```

```
[ :SENSe ] :PFERror :BSYNc :SOURce?
```

Select the method of synchronizing the measurement to the GSM bursts.

EXTernal 1 - burst sync at front panel external trigger input

EXTernal 2 - burst sync at rear panel external trigger input

Training Sequence (TSEQence) - the training sequence burst sync performs a demodulation of the burst and determines the start and stop of the useful part of the burst based on the midamble training sequence.

RFBurst - the RF amplitude burst sync approximates the start and stop of the useful part of the burst without demodulation of the burst.

None - no burst synchronization is used

Factory Preset: TSEQence

Remarks: You must be in the GSM, EDGE mode to use this command. Use INSTRument:SElect to set the mode.

Phase & Frequency Error—Trigger Source

```
[ :SENSe ] :PFERror :TRIGger :SOURce  
EXTernal[1] | EXTernal2 | FRAME | IF | IMMEDIATE | RFBurst
```

```
[ :SENSe ] :PFERror :TRIGger :SOURce?
```

Select the trigger source used to control the data acquisitions.

EXTernal 1 - front panel external trigger input.

EXTernal 2 - rear panel external trigger input.

FRAME - uses the internal frame timer, which has been synchronized to the selected burst sync.

IF - internal IF envelope (video) trigger.

IMMEDIATE - the next data acquisition is immediately taken, capturing the signal asynchronously (also called free run).

RFBurst - wideband RF burst envelope trigger that has automatic level control for periodic burst signals.

Factory Preset: RFBurst

Remarks: You must be in the GSM, EDGE mode to use this command. Use INSTRument:SElect to set the mode.

RF Power Commands

RF Port Input Attenuation

```
[ :SENSe]:POWER[:RF]:ATTenuation <rel_power>
```

```
[ :SENSe]:POWER[:RF]:ATTenuation?
```

Set the RF input attenuator. This value is set at its auto value if RF input attenuation is set to auto.

Factory Preset: 0 dB

Range: 0 to 40 dB

Default Unit: dB

Front Panel

Access: Input, Input Atten

RF Port Power Range Auto

```
[ :SENSe]:POWER[:RF]:RANGe:AUTO OFF|ON|0|1
```

```
[ :SENSe]:POWER[:RF]:RANGe:AUTO?
```

Select the RF port power range to be set either automatically or manually.

ON - power range is automatically set as determined by the actual measured power level at the start of a measurement.

OFF - power range is manually set

Factory Preset: ON

Remarks: You must be in the cdmaOne, GSM, EDGE, NADC, PDC, cdma2000, W-CDMA, mode to use this command. Use INSTRument:SElect to set the mode.

Front Panel

Access: Input, Max Total Pwr (at UUT)

RF Port Power Range Maximum Total Power

```
[ :SENSe]:POWER[:RF]:RANGe[:UPPer] <power>
```

```
[ :SENSe]:POWER[:RF]:RANGe[:UPPer]?
```

Set the maximum expected total power level at the radio unit under test. This value is ignored if RF port power range is set to auto. External attenuation required above 30 dBm.

Factory Preset: -15.0 dBm

Programming Commands
SENSe Subsystem

Range: –100.0 to 80.0 dBm for EDGE, GSM
 –100.0 to 27.7 dBm for cdmaOne
 –200.0 to 50.0 dBm for NADC, PDC
 –200.0 to 100.0 dBm for cdma2000, W-CDMA

Default Unit: dBm

Remarks: Global to the current mode. This is coupled to the RF
 input attenuation

 You must be in the cdmaOne, GSM, EDGE, NADC,
 PDC, cdma2000, W-CDMA mode to use this command.
 Use INSTRument:SElect to set the mode.

Front Panel

Access: **Input, Max Total Pwr (at UUT)**

Power vs. Time Measurement

Commands for querying the power versus time measurement results and for setting to the default values are found in the “MEASure Group of Commands” on page 206. The equivalent front panel keys for the parameters described in the following commands, are found under the Meas Setup key, after the GMSK Pwr vs Time measurement has been selected from the MEASURE key menu.

Power vs. Time—Number of Bursts Averaged

```
[ :SENSE]:PVTTime:AVERAge:COUNT <integer>
```

```
[ :SENSE]:PVTTime:AVERAge:COUNT?
```

Set the number of bursts that will be averaged. After the specified number of bursts (average counts), the averaging mode (terminal control) setting determines the averaging action.

Factory Preset: 15

Range: 1 to 10,000

Remarks: You must be in the GSM, EDGE mode to use this command. Use INSTRument:SElect to set the mode.

Power vs. Time—Averaging State

```
[ :SENSE]:PVTTime:AVERAge[:STATe] OFF|ON|0|1
```

```
[ :SENSE]:PVTTime:AVERAge[:STATe]?
```

Turn averaging on or off.

Factory Preset: OFF

Remarks: You must be in the GSM, EDGE mode to use this command. Use INSTRument:SElect to set the mode.

Power vs. Time—Averaging Mode

```
[ :SENSE]:PVTTime:AVERAge:TCONtrol EXPonential|REPeat
```

```
[ :SENSE]:PVTTime:AVERAge:TCONtrol?
```

Select the type of termination control used for the averaging function. This specifies the averaging action after the specified number of bursts (average count) is reached.

EXPonential - Each successive data acquisition after the average count is reached is exponentially weighted and combined with the existing average.

REPeat - After reaching the average count, the averaging is reset and a new average is started.

Factory Preset: EXponential

Remarks: You must be in the GSM, EDGE mode to use this command. Use INSTRument:SElect to set the mode.

Power vs. Time—Averaging Type

```
[ :SENSe ] :PVTime :AVERAge :TYPE  
LOG | MAXimum | MINimum | MXMinimum | RMS
```

```
[ :SENSe ] :PVTime :AVERAge :TYPE?
```

Select the type of averaging to be performed.

LOG - The log of the power is averaged. (This is also known as video averaging.)

MAXimum - The maximum values are retained.

MINimum - The minimum values are retained.

MXMinimum - Both the maximum and the minimum values are retained.

RMS - The power is averaged, providing the rms of the voltage.

Factory Preset: RMS

Remarks: You must be in the GSM, EDGE mode to use this command. Use INSTRument:SElect to set the mode.

Power vs. Time—Resolution BW

```
[ :SENSe ] :PVTime :BANDwidth | BWIDth [ :RESolution ] <freq>
```

```
[ :SENSe ] :PVTime :BANDwidth | BWIDth [ :RESolution ]?
```

Set the resolution BW. This is an advanced control that normally does not need to be changed. Setting this to a value other than the factory default, may cause invalid measurement results.

Factory Preset: 500 kHz

Range: 1 kHz to 5 MHz

Default Unit: Hz

Remarks: You must be in the GSM, EDGE mode to use this command. Use INSTRument:SElect to set the mode.

Power vs. Time—RBW Filter Type

```
[ :SENSe]:PVTIme:BAWdwidth|BWIDth[:RESolution]:TYPE  
FLATtop|GAUSSian
```

```
[ :SENSe]:PVTIme:BAWdwidth|BWIDth[:RESolution]:TYPE?
```

Select the type of resolution BW filter. This is an advanced control that normally does not need to be changed. Setting this to a value other than the factory default, may cause invalid measurement results.

FLATtop - a filter with a flat amplitude response, which provides the best amplitude accuracy.

GAUSSian - a filter with Gaussian characteristics, which provides the best pulse response.

Factory Preset: GAUSSian

Remarks: You must be in the GSM, EDGE mode to use this command. Use INSTRument:SElect to set the mode.

Power vs. Time—Burst Synchronization Source

```
[ :SENSe]:PVTIme:BSYNc:SOURce RFBurst|TSEquence
```

```
[ :SENSe]:PVTIme:BSYNc:SOURce?
```

Select the method of synchronizing the measurement to the GSM bursts.

RFBurst - the RF burst sync approximates the start and stop of the useful part of the burst without digital demodulation of the burst.

Training Sequence (TSEquence) - the training sequence burst sync performs a demodulation of the burst and determines the start and stop of the useful part of the burst based on the midamble training sequence.

Factory Preset: RFBurst

Remarks: You must be in the GSM, EDGE mode to use this command. Use INSTRument:SElect to set the mode.

Power vs. Time—Limit Line Mask Display

```
[ :SENSe]:PVTIme:LIMit:MASK OFF|ON|0|1
```

```
[ :SENSe]:PVTIme:LIMit:MASK?
```

Show or hide the limit mask. Does not affect limit pass/fail calculation.

Factory Preset: ON

Range: ON/OFF

Remarks: You must be in GSM, EDGE mode to use this command.
Use INSTRument:SElect to set the mode.

Power vs. Time—Lower Mask Absolute Amplitude Levels

```
[ :SENSe ] :PVTime :MASK :LIST :LOWer :ABSolute <power> { , <power> }
```

```
[ :SENSe ] :PVTime :MASK :LIST :LOWer :ABSolute?
```

Enter a power level for any of your mask line segments that require an absolute minimum power limit in addition to its relative limit. Each time a measurement is made the Ref Level is determined. (This is the power level of the useful part of the burst, or midway between the upper/lower masks). Remember, as the power of the Ref Level changes, all of the relative mask power levels will change by the same amount.

Each relative limit is then compared to the Ref Level and an equivalent absolute power level is calculated. This power level is compared to the specified absolute limit for each line segment. If this calculated relative limit is lower than the absolute limit you've specified, then the value of the absolute limit is used for this segment. Therefore, if the absolute limit is set to a very low value (–200 dBm), the calculated value of the reference limit will never be lower, and the specified relative limit will always be used for that segment. See [Figure 4-5 on page 300](#).

Every time point you defined with PVT:MASK:LOW:TIME must have a power value defined in the same order. You can put a comma in the SCPI command as a place holder for any points where an absolute power is not specified, and that segment will then use the default value.

Factory Preset: Selected GSM standard

Range: –200 dBm to +100 dBm

Default Unit: dBm

Remarks: You must be in GSM, EDGE mode to use this command.
Use INSTRument:SElect to set the mode.

Power vs. Time—Lower Mask Points

```
[ :SENSe ] :PVTime :MASK :LIST :LOWer :POINTs?
```

Query the number of elements in the lower mask. This value is determined by the number of time points entered using

```
[ :SENSe ] :PVTime :MASK :LIST :LOWer :TIME.
```

Range: Integer, 1 to 25

Remarks: You must be in GSM, EDGE mode to use this command.
Use INSTRument:SElect to set the mode.

Power vs. Time—Lower Mask Relative Amplitude Levels

```
[ :SENSE]:PVTIME:MASK:LIST:LOWER:RELATIVE  
<rel_power>{,<rel_power>}
```

```
[ :SENSE]:PVTIME:MASK:LIST:LOWER:RELATIVE?
```

Enter the relative power level for each horizontal line segment in the lower limit mask. There should be a power level for each time point entered using `[:SENSE]:PVTIME:MASK:LIST:LOWER:TIME`, and they must be entered in the same order. These power levels are all relative to the defined Reference Power Level (the average power in the useful part of the data). When an upper and lower limit mask have been defined, the Reference Power Level is the mid-point between these two limits at time t_0 .

Any portion of the signal that has no limit line segment defined for it, will default to a very low limit (–100 dB relative to the reference power). This will keep the measurement from indicating a failure for that portion of the data.

Factory Preset: Selected GSM standard

Range: +200 dB to –100 dB, relative to the reference power

Default Unit: dB

Remarks: You must be in GSM, EDGE mode to use this command.
Use `INSTRUMENT:SELECT` to set the mode.

Power vs. Time—Lower Mask Time Points

```
[ :SENSE]:PVTIME:MASK:LIST:LOWER:TIME <seconds>{,<seconds>}
```

```
[ :SENSE]:PVTIME:MASK:LIST:LOWER:TIME?
```

Enter the time points that define the horizontal line segments of the lower limit. A reference point designated “ t_0 ” is at the center of the useful data (usually the center of the burst). Each line segment to the right of the t_0 reference point is designated as a positive time value and each segment to the left of t_0 is a negative time value.

First enter positive values in sequence starting from t_0 , then negative values in sequence starting from t_0 . See [Figure 4-5 on page 300](#) and the `PVT:MASK:LIST:UPPER:TIME` example below it. (This is an upper mask example, but they work the same.)

We recommend that you select a large time value for your first and last mask points (e.g. –1 and +1 second). This guarantees that you’ve defined a limit for all the measured data. (See [Mask Segments 4 and 9 in the Table on page 300](#) for an example.)

Factory Preset: Selected GSM standard

Range: -1s to +1s, referenced to t_0 at the center of the useful data (burst center)
1 to 25 time points in a mask

Default Unit: seconds

Remarks: You must be in GSM, EDGE mode to use this command.
Use INSTRument:SElect to set the mode.

Power vs. Time—Upper Mask Absolute Amplitude Levels

```
[ :SENSe ] :PVTime:MASK:LIST:UPPER:ABSolute <power>{ ,<power> }
```

```
[ :SENSe ] :PVTime:MASK:LIST:UPPER:ABSolute?
```

Enter a power level for any of your mask line segments that require an absolute minimum power limit in addition to its relative limit. Each time a measurement is made the Ref Level is determined. (This is the power level of the useful part of the burst, or midway between the upper/lower masks). Remember, as the power of the Ref Level changes, all of the relative mask power levels will change by the same amount.

Each relative limit is then compared to the Ref Level and an equivalent absolute power level is calculated. This power level is compared to the specified absolute limit for each line segment. If this calculated relative limit is lower than the absolute limit you've specified, then the value of the absolute limit is used for this segment. Therefore, if the absolute limit is set to a very low value (-200 dBm), the calculated value of the reference limit will never be lower, and the specified relative limit will always be used for that segment. See [Figure 4-5 on page 300](#).

Every time point you defined with PVT:MASK:LOW:TIME must have a power value defined in the same order. You can put a comma in the SCPI command as a place holder for any points where an absolute power is not specified, and that segment will then use the default value.

Example: PVT:MASK:LIST:UPP:ABS -200, -200, -58, -200,
-200, -200, -200, -58, -200

Factory Preset: Selected GSM standard

Range: -200 dBm to +100 dBm

Default Unit: dBm

Remarks: You must be in GSM, EDGE mode to use this command.
Use INSTRument:SElect to set the mode.

Power vs. Time—Upper Mask Points

`[:SENSE]:PVTime:MASK:LIST:UPPER:POINTS?`

Query the number of elements in the upper mask. This value is determined by the number of time points entered using

`[:SENSE]:PVTime:MASK:LIST:UPPER:TIME.`

Range: integer, 1 to 25

Remarks: You must be in GSM, EDGE mode to use this command.
Use `INSTRUMENT:SELEct` to set the mode.

Power vs. Time—Upper Mask Relative Amplitude Levels

`[:SENSE]:PVTime:MASK:LIST:UPPER:RELATIVE
<rel_power>{ ,<rel_power> }`

`[:SENSE]:PVTime:MASK:LIST:UPPER:RELATIVE?`

Enter the relative power level for each horizontal line segment in the upper limit mask. There should be a power level for each time point entered using `[:SENSE]:PVTime:MASK:LIST:UPPER:TIME`, and they must be entered in the same order. These power levels are all relative to the defined Reference Power Level (the average power in the useful part of the data). When an upper and lower limit mask have been defined, the Reference Power Level is the mid-point between these two limits at time t_0 . See [Figure 4-5 on page 300](#).

Example: `PVT:MASK:LIST:UPPER:REL 4, -32, -48, 100, 4, 7,
-25, -43, 100`

Factory Preset: Selected GSM standard

Range: 200 dB to -100 dB, relative to the reference power

Default Unit: dB

Remarks: You must be in GSM, EDGE mode to use this command.
Use `INSTRUMENT:SELEct` to set the mode.

Power vs. Time—Upper Mask Time Points

`[:SENSE]:PVTime:MASK:LIST:UPPER:TIME <seconds>{ ,<seconds> }`

`[:SENSE]:PVTime:MASK:LIST:UPPER:TIME?`

Enter the time points that define the horizontal line segments of the upper limit. A reference point designated “ t_0 ” is at the center of the useful data (usually the center of the burst). Each line segment to the right of the t_0 reference point is designated as a positive time value and each segment to the left of t_0 is a negative time value.

First enter positive values in sequence starting from t_0 , then the negative values in sequence starting from t_0 . See [Figure 4-5 on page 300](#) and the `PVTime:MASK:LIST:UPPer:TIME` example below it.

We recommend that you select a large time value for your first and last mask points (e.g. -1 and $+1$ second). This guarantees that you've defined a limit for all the measured data. (See Mask Segments 4 and 9 in the table [Table on page 300](#) for an example).

Figure 4-5 Custom Upper Limit Mask Example

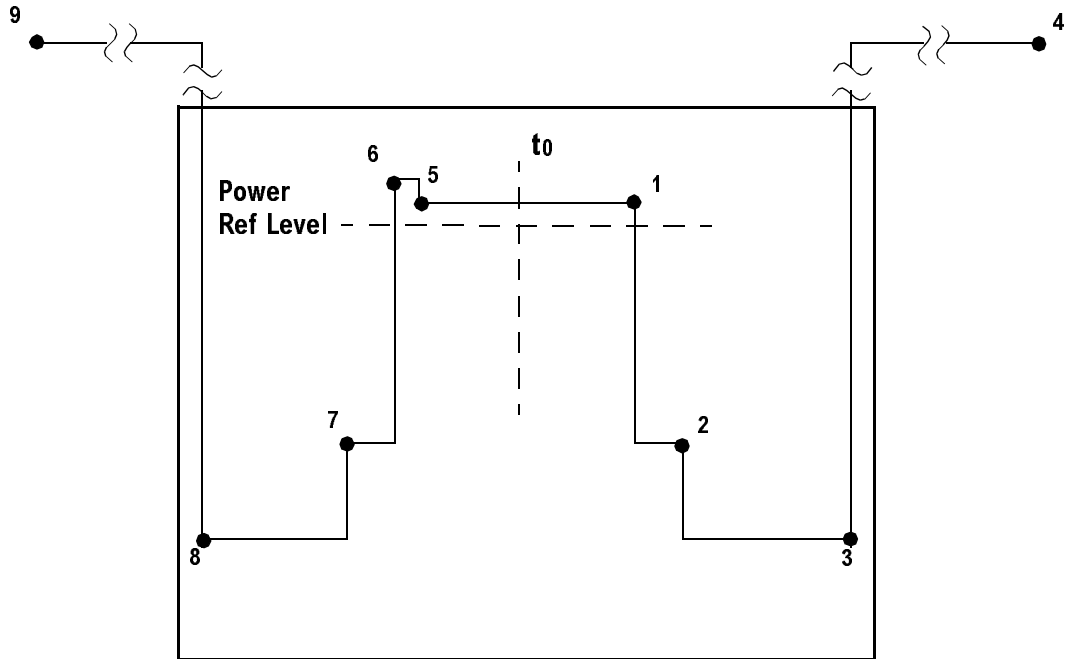

Entered Value for each Time Segment	Absolute Time Value	Relative Power (example with Ref Level = -12 dBm)		Entered Absolute Power (dBm)	Segment Number
		Entered Relative Power	Equivalent Absolute Power		
280.0e-6	280 μ s	+4 dBc	-8 dBm	-200 dBm	1
15.0e-6	295 μ s	-32 dBc	-44 dBm	-200 dBm	2
450.0e-6	745 μ s	-48 dBc	-60 dBm ^a	-58 dBm ^a	3
1	>1 sec	+100 dBc	+112 dBm	-200 dBm	4
-270.0 e-6	-270 μ s	+4 dBc	-8 dBm	-200 dBm	5
-10.0 e-6	-280 μ s	+7 dBc	-5 dBm	-200 dBm	6

Entered Value for each Time Segment	Absolute Time Value	Relative Power (example with Ref Level = -12 dBm)		Entered Absolute Power (dBm)	Segment Number
		Entered Relative Power	Equivalent Absolute Power		
-20.0e-6	-300 μ s	-25 dBc	-37 dBm	-200 dBm	7
-450e-6	-750 μ s	-43 dBc	-55 dBm	-58 dBm	8
-1	<-1 sec	+100 dBc	+112 dBm	-200 dBm	9

- a. Notice that this segment, with this value of Ref Level, has a calculated relative level of -60 dBm. This is lower than the specified absolute level of -58 dBm, so the -58 dBm value will be used as the test limit for the segment.

Example: `PVTime:MASK:LIST:UPPER:TIME 280e-6, 15e-6, 450e-6, 1, -270e-6, -10e-6, -20e-6, -450e-6, -1`

Factory Preset: Selected GSM standard

Range: -1s to +1s, referenced to t_0 at the center of the useful data (burst center)

1 to 25 time points in a mask

Default Unit: seconds

Remarks: You must be in GSM, EDGE mode to use this command. Use INSTRUMENT:SELEct to set the mode.

Power vs. Time—Custom Limit Masks

`[:SENSE]:PVTime:MASK:SELEct STANDARD|CUSTOM`

`[:SENSE]:PVTime:MASK:SELEct?`

Select standard masks or user-defined custom masks to compare you measured data against.

Factory Preset: STANDARD

Remarks: You must be in GSM, EDGE mode to use this command. Use INSTRUMENT:SELEct to set the mode.

Power vs Time - Select Power Control Level

Allows user to indicate the output power of the transmitter; in MS testing transmitter output power level will affect the mask. The appropriate power level for measuring the device under test will correspond with the transmitter power control level setting.

[:SENSe]:PVTime:PCLevel <integer>

[:SENSe]:PVTime:PCLevel?

Range: 0 to 40

Remarks: You must be in the power vs. time measurement in GSM, EDGE mode to use this command. Use INSTRument:SElect to set the mode

Front Panel Access: Meas Setup, More (1 of 2), Pwr Cntrl Lvl.

Power vs. Time—Sweep Time

[:SENSe]:PVTime:SWEep:TIME <integer>

[:SENSe]:PVTime:SWEep:TIME?

Set the number of slots which are used in each data acquisition. Each slot is approximately equal to 570 ms. The measurement is made for a small additional amount of time (about 130 μ s) in order to view the burst edges.

Factory Preset: 1

Range: 1 to 50 (for resolution BW = 500 kHz)

Remarks: You must be in the GSM, EDGE mode to use this command. Use INSTRument:SElect to set the mode.

Power vs. Time—Trigger Source

[:SENSe]:PVTime:TRIGger:SOURce EXTErnal[1]|EXTErnal2
|FRAMe|IF|IMMediate|RFBurst

[:SENSe]:PVTime:TRIGger:SOURce?

Select the trigger source used to control the data acquisitions.

EXTErnal 1 - front panel external trigger input

EXTErnal 2 - rear panel external trigger input

FRAMe - uses the internal frame timer, which has been synchronized to the selected burst sync.

IF - internal IF envelope (video) trigger

IMMediate - the next data acquisition is immediately taken, capturing the signal asynchronously (also called Free Run).

RFBurst - wideband RF burst envelope trigger that has automatic level control for periodic burst signals.

Factory Preset: RFBurst if the RF Burst Hardware (option B7E) has

been installed

EXternal, if option B7E has not been installed

Remarks:

You must be in the GSM, EDGE mode to use this command. Use INSTRument:SElect to set the mode.

Radio Standards Commands

Radio Carrier Hopping

```
[ :SENSe ]:RADIo:CARRier:HOP OFF|ON|0|1
```

```
[ :SENSe ]:RADIo:CARRier:HOP?
```

Turns the carrier hopping mode on and off.

Factory Preset: OFF

Remarks: Global to the current mode.

You must be in the GSM, EDGE mode to use this command. Use INSTRument:SELEct to set the mode.

Front Panel

Access: **Mode Setup, Radio, Carrier**

Radio Carrier Burst

```
[ :SENSe ]:RADIo:CARRier[:TYPE] BURSt|CONTInuous
```

```
[ :SENSe ]:RADIo:CARRier[:TYPE]?
```

Select the type of RF carrier on the device to be tested.

Factory Preset: BURSt

Remarks: You must be in the GSM, EDGE mode to use this command. Use INSTRument:SELEct to set the mode.

Global to the current mode.

Front Panel

Access: **Mode Setup, Radio, Carrier**

Radio Device Under Test

```
[ :SENSe ]:RADIo:DEVIce BTS|MS
```

```
[ :SENSe ]:RADIo:DEVIce?
```

Select the type of radio device to be tested.

BTS - Base station transmitter test

MS - Mobile station transmitter test

Factory Preset: BTS

Remarks: Global to the current mode.

You must be in cdma2000, GSM, EDGE, W-CDMA

mode to use this command. Use INSTRUMENT:SElect to set the mode.

Front Panel

Access: **Mode Setup, Radio, Device**

Radio Base Station Type

```
[ :SENSE]:RADIO:DEVICE:BASE[:TYPE] NORMAL|MICRO|PICO
```

```
[ :SENSE]:RADIO:DEVICE:BASE[:TYPE]?
```

Select the type of base station to be tested. If you are testing a base station, it must be put into the test mode to transmit known bit patterns.

Factory Preset: NORMAL

Remarks: You must be in the GSM, EDGE mode to use this command. Use INSTRUMENT:SElect to set the mode.

Global to current mode.

Front Panel

Access: **Mode Setup, Radio, BTS Type**

Radio Standard Band

```
[ :SENSE]:RADIO:STANDARD:BAND
```

```
PGSM900|EGSM900|RGSM900|DCS1800|PCS1900|GSM450|GSM480|GSM850
```

```
[ :SENSE]:RADIO:STANDARD:BAND?
```

Select the standard variant that applies to the radio to be tested.

EGSM900 - Extended GSM in the 900 MHz band

PGSM900 - Primary GSM in the 900 MHz band

RGSM900 - Railway GSM in the 900 MHz band

DCS1800 - DSC1800 band; also known as GSM-1800

PCS - PCS1900 band; also known as GSM-1900

GSM450 - GSM450 band

GSM480 - GSM480 band

GSM850 - GSM850 band, for IS-136HS

Factory Preset: EGSM-900

Remarks: Global to the current mode.

Programming Commands
SENSe Subsystem

You must be in GSM, EDGE mode to use this command.
Use INSTRUMENT:SElect to set the mode.

Front Panel

Access: **Mode Setup, Radio, Band**

Spectrum (Frequency-Domain) Measurement

Commands for querying the spectrum measurement results and for setting to the default values are found in the “MEASure Group of Commands” on page 206. The equivalent front panel keys for the parameters described in the following commands, are found under the Meas Setup key, after the Spectrum (Freq Domain) measurement has been selected from the MEASURE key menu.

Spectrum—Data Acquisition Packing

```
[ :SENSE ] :SPECTrum:ACQuisition:PACKing
AUTO | LONG | MEdium | SHORt
```

```
[ :SENSe ] :SPECTrum:ACQuisition:PACKing?
```

Select the amount of data acquisition packing. This is an advanced control that normally does not need to be changed.

Factory Preset: AUTO

Remarks: You must be in the Basic, cdmaOne, cdma2000, W-CDMA, GSM, EDGE, NADC, or PDC mode to use this command. Use INSTRument:SElect to set the mode.

Spectrum—ADC Dither

```
[ :SENSE ] :SPECTrum:ADC:DITHer [ :STATE ] AUTO | ON | OFF | 2 | 1 | 0
```

```
[ :SENSe ] :SPECTrum:ADC:DITHer [ :STATE ] ?
```

Turn the ADC dither on or off. This is an advanced control that normally does not need to be changed.

Factory Preset: AUTO

Remarks: You must be in the Basic, cdmaOne, cdma2000, W-CDMA, GSM, EDGE, NADC, or PDC mode to use this command. Use INSTRument:SElect to set the mode.

Spectrum—ADC Range

```
[ :SENSE ] :SPECTrum:ADC:RANGe
AUTO | APeak | APLock | NONE | P0 | P6 | P12 | P18
```

```
[ :SENSe ] :SPECTrum:ADC:RANGe?
```

Select the range for the gain-ranging that is done in front of the ADC. This is an advanced control that normally does not need to be changed. Auto peak ranging is the default for this measurement. If you are

measuring a CW signal please see the description below.

- **AUTO** - automatic range
For FFT spectrums - auto ranging should not be used. An exception to this would be if you know that your signal is “bursty”. Then you might use auto to maximize the time domain dynamic range as long as you are not very interested in the FFT data.
- **Auto Peak (APEak)** - automatically peak the range
For CW signals, the default of auto-peak ranging can be used, but a better FFT measurement of the signal can be made by selecting one of the manual ranges that are available: M6, P0 - P24. Auto peaking can cause the ADC range gain to move monotonically down during the data capture. This movement should have negligible effect on the FFT spectrum, but selecting a manual range removes this possibility. Note that if the CW signal being measured is close to the auto-ranging threshold, the noise floor may shift as much as 6 dB from sweep to sweep.
- **Auto Peak Lock (APLock)** - automatically peak lock the range
For CW signals, auto-peak lock ranging may be used. It will find the best ADC measurement range for this particular signal and will not move the range as auto-peak can. Note that if the CW signal being measured is close to the auto-ranging threshold, the noise floor may shift as much as 6 dB from sweep to sweep. For “bursty” signals, auto-peak lock ranging should not be used. The measurement will fail to operate, since the wrong (locked) ADC range will be chosen often and overloads will occur in the ADC.
- **NONE** - turns off any auto-ranging without making any changes to the current setting.
- **P0 to P18** - manually selects ADC ranges that add 0 to 18 dB of fixed gain across the range. Manual ranging is best for CW signals.

Factory Preset: APEak

Remarks: You must be in the Basic, cdmaOne, cdma2000, W-CDMA, GSM, EDGE, NADC, or PDC mode to use this command. Use INSTRument:SElect to set the mode.

Spectrum—Average Clear

[:SENSe] :SPECTrum:AVERAge:CLEar

The average data is cleared and the average counter is reset.

Remarks: You must be in the Basic, cdmaOne, cdma2000, W-CDMA, GSM, EDGE, NADC, or PDC mode to use this command. Use INSTRument:SElect to set the mode.

Spectrum—Number of Averages

```
[ :SENSe ] :SPECTrum:AVERAge:COUNT <integer>
```

```
[ :SENSe ] :SPECTrum:AVERAge:COUNT?
```

Set the number of 'sweeps' that will be averaged. After the specified number of 'sweeps' (average counts), the averaging mode (terminal control) setting determines the averaging action.

Factory Preset: 25

Range: 1 to 10,000

Remarks: You must be in the Basic, cdmaOne, cdma2000, W-CDMA, GSM, EDGE, NADC, or PDC mode to use this command. Use INSTRument:SElect to set the mode.

Spectrum—Averaging State

```
[ :SENSe ] :SPECTrum:AVERAge[ :STATe ] OFF|ON|0|1
```

```
[ :SENSe ] :SPECTrum:AVERAge[ :STATe ]?
```

Turn averaging on or off.

Factory Preset: ON

Remarks: You must be in the Basic, cdmaOne, cdma2000, W-CDMA, GSM, EDGE, NADC, or PDC mode to use this command. Use INSTRument:SElect to set the mode.

Spectrum—Averaging Mode

```
[ :SENSe ] :SPECTrum:AVERAge:TCONtrol EXPonential|REPEat
```

```
[ :SENSe ] :SPECTrum:AVERAge:TCONtrol?
```

Select the type of termination control used for the averaging function. This determines the averaging action after the specified number of 'sweeps' (average count) is reached.

EXPonential - Each successive data acquisition after the average count is reached, is exponentially weighted and combined with the

existing average.

REPeat - After reaching the average count, the averaging is reset and a new average is started.

Factory Preset: EXPonential

Remarks: You must be in the Basic, cdmaOne, cdma2000, W-CDMA, GSM, EDGE, NADC, or PDC mode to use this command. Use INSTRument:SElect to set the mode.

Spectrum—Averaging Type

```
[ :SENSe ] :SPECTrum:AVERAge:TYPE  
LOG | MAXimum | MINimum | RMS | SCALar
```

```
[ :SENSe ] :SPECTrum:AVERAge:TYPE?
```

Select the type of averaging.

LOG – The log of the power is averaged. (This is also known as video averaging.)

MAXimum – The maximum values are retained.

MINimum – The minimum values are retained.

RMS – The power is averaged, providing the rms of the voltage.

SCALar – The voltage is averaged.

Factory Preset: LOG

Remarks: You must be in the Basic, cdmaOne, cdma2000, W-CDMA, GSM, EDGE, NADC, or PDC mode to use this command. Use INSTRument:SElect to set the mode.

Spectrum— Select Pre-FFT Bandwidth

```
[ :SENSe ] :SPECTrum:BANDwidth | BWIDth:IF:AUTO OFF | ON | 0 | 1
```

```
[ :SENSe ] :SPECTrum:BANDwidth | BWIDth:IF:AUTO?
```

Select auto or manual control of the pre-FFT BW.

Factory Preset: AUTO, 1.55 MHz

Remarks: You must be in the Basic, cdmaOne, cdma2000, W-CDMA, GSM, EDGE, NADC, or PDC mode to use this command. Use INSTRument:SElect to set the mode.

Front Panel

Access: **Measure, Spectrum, Meas Setup, More, Advanced, Pre-FFT BW.**

Spectrum — IF Flatness Corrections

```
[ :SENSe]:SPECTrum:BAWdwidth|BWIDth:IF:FLATness OFF|ON|0|1
```

```
[ :SENSe]:SPECTrum:BAWdwidth|BWIDth:IF:FLATness?
```

Turns IF flatness corrections on and off.

Factory Preset: ON

Remarks: You must be in the Basic, cdmaOne, cdma2000, W-CDMA, GSM, EDGE, NADC, or PDC mode to use this command. Use INSTRument:SElect to set the mode.

Front Panel

Access: **Measure, Spectrum, Meas Setup, More, Advanced, Pre-FFT BW**

Spectrum—Pre-ADC Bandpass Filter

```
[ :SENSe]:SPECTrum:BAWdwidth|BWIDth:PADC OFF|ON|0|1
```

```
[ :SENSe]:SPECTrum:BAWdwidth|BWIDth:PADC?
```

Turn the pre-ADC bandpass filter on or off. This is an advanced control that normally does not need to be changed.

Remarks: You must be in the Basic, cdmaOne, cdma2000, W-CDMA, GSM, EDGE, NADC, or PDC mode to use this command. Use INSTRument:SElect to set the mode.

Spectrum—Pre-FFT BW

```
[ :SENSe]:SPECTrum:BAWdwidth|BWIDth:PFFT[:SIZE] <freq>
```

```
[ :SENSe]:SPECTrum:BAWdwidth|BWIDth:PFFT[:SIZE]?
```

Set the pre-FFT bandwidth. This is an advanced control that normally does not need to be changed.

Frequency span, resolution bandwidth, and the pre-FFT bandwidth settings are normally coupled. If you are not auto-coupled, there can be combinations of these settings that are not valid.

Factory Preset: 1.55 MHz

1.25 MHz for cdmaOne

Range: 1 Hz to 10.0 MHz

Remarks: You must be in the Basic, cdmaOne, cdma2000, W-CDMA, GSM, EDGE, NADC, or PDC mode to use this command. Use INSTRUMENT:SElect to set the mode.

Spectrum—Pre-FFT BW Filter Type

```
[ :SENSe ] :SPECTrum :BANDwidth | BWIDth :PFFT :TYPE FLAT | GAUSSian
```

```
[ :SENSe ] :SPECTrum :BANDwidth | BWIDth :PFFT :TYPE ?
```

Select the type of pre-FFT filter that is used. This is an advanced control that normally does not need to be changed.

Flat top (FLAT)- a filter with a flat amplitude response, which provides the best amplitude accuracy.

GAUSSian - a filter with Gaussian characteristics, which provides the best pulse response.

Factory Preset: FLAT

Remarks: You must be in the Basic, cdmaOne, cdma2000, W-CDMA, GSM, EDGE, NADC, or PDC mode to use this command. Use INSTRUMENT:SElect to set the mode.

Spectrum—Resolution BW

```
[ :SENSe ] :SPECTrum :BANDwidth | BWIDth [ :RESolution ] <freq>
```

```
[ :SENSe ] :SPECTrum :BANDwidth | BWIDth [ :RESolution ] ?
```

Set the resolution bandwidth for the FFT. This is the bandwidth used for resolving the FFT measurement. It is not the pre-FFT bandwidth. This value is ignored if the function is auto-coupled.

Frequency span, resolution bandwidth, and the pre-FFT bandwidth settings are normally coupled. If you are not auto-coupled, there can be combinations of these settings that are not valid.

Factory Preset: 20.0 kHz

Range: 0.10 Hz to 3.0 MHz

Remarks: You must be in the Basic, cdmaOne, cdma2000, W-CDMA, GSM, EDGE, NADC, or PDC mode to use this command. Use INSTRUMENT:SElect to set the mode.

Spectrum—Resolution BW Auto

```
[ :SENSE]:SPECTrum:BANDwidth|BWIDth[:RESolution]:AUTO  
OFF|ON|0|1
```

```
[ :SENSe]:SPECTrum:BANDwidth|BWIDth[:RESolution]:AUTO?
```

Select auto or manual control of the resolution BW. The automatic mode couples the resolution bandwidth setting to the frequency span.

Factory Preset: ON

Remarks: You must be in the Basic, cdmaOne, cdma2000, W-CDMA, GSM, EDGE, NADC, or PDC mode to use this command. Use INSTRument:SElect to set the mode.

Decimation of Spectrum Display

```
[ :SENSe ] :SPECTrum:DECimate[ :FACTOR ] <integer>
```

```
[ :SENSe ] :SPECTrum:DECimate[ :FACTOR ]?
```

Sets the amount of data decimation done by the hardware and/or the software. Decimation by *n* keeps every *n*th sample, throwing away each of the remaining samples in the group of *n*. For example, decimation by 3 keeps every third sample, throwing away the two in between. Similarly, decimation by 5 keeps every fifth sample, throwing away the four in between.

Using zero (0) decimation selects the automatic mode. The measurement will then automatically choose decimation by “1” or “2” as is appropriate for the bandwidth being used.

This is an advanced control that normally does not need to be changed.

Factory Preset: 0

Range: 0 to 1,000, where 0 sets the function to automatic

Remarks: You must be in the Basic, cdmaOne, cdma2000, W-CDMA, GSM, EDGE, NADC, or PDC mode to use this command. Use INSTRument:SElect to set the mode.

Spectrum—FFT Length

```
[ :SENSe ] :SPECTrum:FFT:LENGth <integer>
```

```
[ :SENSe ] :SPECTrum:FFT:LENGth?
```

Set the FFT length. This value is only used if length control is set to manual. The value must be greater than or equal to the window length value. Any amount greater than the window length is implemented by zero-padding. This is an advanced control that normally does not need to be changed.

Factory Preset: 706

Range: min, depends on the current setting of the spectrum window length

max, 1,048,576

Remarks: You must be in the Basic, cdmaOne, cdma2000, W-CDMA, GSM, EDGE, NADC, or PDC mode to use this command. Use INSTRument:SElect to set the mode.

Spectrum—FFT Length Auto

[:SENSE] :SPECTrum:FFT:LENGth:AUTO OFF | ON | 0 | 1

[:SENSe] :SPECTrum:FFT:LENGth:AUTO?

Select auto or manual control of the FFT and window lengths.

This is an advanced control that normally does not need to be changed.

On - the window lengths are coupled to resolution bandwidth, window type (FFT), pre-FFT bandwidth (sample rate) and SENSE:SPECTrum:FFT:RBWPoints.

Off - lets you set SENSE:SPECTrum:FFT:LENGth and SENSE:SPECTrum:FFT:WINDow:LENGth.

Factory Preset: ON

Remarks: You must be in the Basic, cdmaOne, cdma2000, W-CDMA, GSM, EDGE, NADC, or PDC mode to use this command. Use INSTRument:SElect to set the mode.

Spectrum—FFT Minimum Points in Resolution BW

[:SENSe] :SPECTrum:FFT:RBWPoints <real>

[:SENSe] :SPECTrum:FFT:RBWPoints?

Set the minimum number of data points that will be used inside the resolution bandwidth. The value is ignored if length control is set to manual. This is an advanced control that normally does not need to be changed.

Factory Preset: 1.30

Range: 0.1 to 100

Remarks: You must be in the Basic, cdmaOne, cdma2000, W-CDMA, GSM, EDGE, NADC, or PDC mode to use this command. Use INSTRument:SElect to set the mode.

Spectrum—Window Delay

[:SENSe] :SPECTrum:FFT:WINDow:DELay <real>

[:SENSe] :SPECTrum:FFT:WINDow:DELay?

Set the FFT window delay to move the FFT window from its nominal position of being centered within the time capture. This function is not available from the front panel. It is an advanced control that normally does not need to be changed.

Factory Preset: 0

Range: -10.0 to +10.0s

Default Unit: seconds

Remarks: You must be in the Basic, cdmaOne, cdma2000, W-CDMA, GSM, EDGE, NADC, or PDC mode to use this command. Use INSTRument:SElect to set the mode.

Spectrum—Window Length

```
[ :SENSe ] :SPECTrum:FFT:WINDow:LENGth <integer>
```

```
[ :SENSe ] :SPECTrum:FFT:WINDow:LENGth?
```

Set the FFT window length. This value is only used if length control is set to manual. This is an advanced control that normally does not need to be changed.

Factory Preset: 706

Range: 8 to 1,048,576

Remarks: You must be in the Basic, cdmaOne, cdma2000, W-CDMA, GSM, EDGE, NADC, or PDC mode to use this command. Use INSTRument:SElect to set the mode.

Spectrum—FFT Window

```
[ :SENSe ] :SPECTrum:FFT:WINDow[ :TYPE ]
```

```
BH4Tap | BLACkman | FLATtop | GAUSSian | HAMMing | HANNing | KB70 | KB90 |  
KB110 | UNIFORM
```

```
[ :SENSe ] :SPECTrum:FFT:WINDow[ :TYPE ]?
```

Select the FFT window type.

BH4Tap - Blackman Harris with 4 taps

BLACkman - Blackman

FLATtop - flat top, the default (for high amplitude accuracy)

GAUSSian - Gaussian with alpha of 3.5

HAMMing - Hamming

HANNing - Hanning

KB70, 90, and 110 - Kaiser Bessel with sidelobes at -70, -90, or -110 dBc

UNIFORM - no window is used. (This is the unity response.)

Factory Preset: FLATtop

Remarks: This selection affects the acquisition point quantity and the FFT size, based on the resolution bandwidth selected.

You must be in the Basic, cdmaOne, cdma2000, W-CDMA, GSM, EDGE, NADC, or PDC mode to use this command. Use INSTRUMENT:SElect to set the mode.

Spectrum—Frequency Span

[:SENSE] :SPECTrum:FREQuency:SPAN <freq>

[:SENSE] :SPECTrum:FREQuency:SPAN?

Set the frequency span to be measured.

Factory Preset: 1.0 MHz

Range: 10 Hz to 10.0 MHz (15 MHz when Service mode is selected)

Default Unit: Hz

Remarks: The actual measured span will generally be slightly wider due to the finite resolution of the FFT.

You must be in the Basic, cdmaOne, cdma2000, W-CDMA, GSM, EDGE, NADC, or PDC mode to use this command. Use INSTRUMENT:SElect to set the mode.

Spectrum—Sweep (Acquisition) Time

[:SENSE] :SPECTrum:SWEep:TIME[:VALue] <time>

[:SENSE] :SPECTrum:SWEep:TIME?

Set the sweep (measurement acquisition) time. It is used to specify the length of the time capture record. If the value you specify is less than the capture time required for the specified span and resolution bandwidth, the value is ignored. The value is set at its auto value when auto is selected. This is an advanced control that normally does not need to be changed.

Factory Preset: 188.0 μ s

Range: 100 ns to 10 s

Default Unit: seconds

Remarks: You must be in the Basic, cdmaOne, cdma2000, W-CDMA, GSM, EDGE, NADC, or PDC mode to use this command. Use INSTRUMENT:SElect to set the mode.

Spectrum—Sweep (Acquisition) Time Auto

```
[ :SENSe ] :SPECTrum:SWEep:TIME:AUTO OFF|ON|0|1
```

```
[ :SENSe ] :SPECTrum:SWEep:TIME:AUTO
```

Select auto or manual control of the sweep (acquisition) time. This is an advanced control that normally does not need to be changed.

AUTO - couples the Sweep Time to the Frequency Span and Resolution BW

Manual - the Sweep Time is uncoupled from the Frequency Span and Resolution BW.

Factory Preset: AUTO

Remarks: You must be in the Basic, cdmaOne, cdma2000, W-CDMA, GSM, EDGE, NADC, or PDC mode to use this command. Use INSTRUMENT:SElect to set the mode.

Spectrum—Trigger Source

```
[ :SENSe ] :SPECTrum:TRIGger:SOURce  
EXTErnal[1] | EXTErnal2 | FRAMe | IF | LINE | IMMEDIATE | RFBURSt
```

```
[ :SENSe ] :SPECTrum:TRIGger:SOURce?
```

Select the trigger source used to control the data acquisitions.

EXTErnal1 - front panel external trigger input

EXTErnal2 - rear panel external trigger input

FRAMe - internal frame timer from front panel input

IF - internal IF envelope (video) trigger

LINE - internal line trigger

IMMEDIATE - the next data acquisition is immediately taken (also called free run)

RFBURSt - wideband RF burst envelope trigger that has automatic level control for periodic burst signals

Factory Preset: IMMEDIATE (free run)

RFBURSt, for GSM mode

Remarks: You must be in the Basic, cdmaOne, cdma2000, W-CDMA, GSM, EDGE, NADC, or PDC mode to use this command. Use INSTRUMENT:SElect to set the mode.

Transmit Band Spurs Measurement

Commands for querying the transmit band spurs measurement results and for setting to the default values are found in the “[MEASure Group of Commands](#)” on page 206. The equivalent front panel keys for the parameters described in the following commands, are found under the **Meas Setup** key, after the **GMSK TxBand Spur** measurement has been selected from the **MEASURE** key menu.

Transmit Band Spurs—Average Count

```
[ :SENSe ] :TSPur :AVERAge :COUNT <integer>
```

```
[ :SENSe ] :TSPur :AVERAge :COUNT?
```

Set the number of data acquisitions that will be averaged. After the specified number of average counts, the averaging mode (terminal control) setting determines the averaging action.

Factory Preset: 15

Range: 1 to 10,000

Remarks: You must be in the GSM, EDGE mode to use this command. Use INSTRument:SElect to set the mode.

Transmit Band Spurs—Averaging State

```
[ :SENSe ] :TSPur :AVERAge [ :STATe ] OFF | ON | 0 | 1
```

```
[ :SENSe ] :TSPur :AVERAge [ :STATe ]?
```

Turn averaging on or off.

Factory Preset: ON

Remarks: You must be in the GSM, EDGE mode to use this command. Use INSTRument:SElect to set the mode.

Transmit Band Spurs—Averaging Termination Control

```
[ :SENSe ] :TSPur :AVERAge :TCONTRol EXPONential | REPeat
```

```
[ :SENSe ] :TSPur :AVERAge :TCONTRol?
```

Select the type of termination control used for the averaging function. This determines the averaging action after the specified number of data acquisitions (average count) is reached.

EXPONential - Each successive data acquisition after the average count is reached, is exponentially weighted and combined with the existing average.

REPeat - After reaching the average count, the averaging is reset

and a new average is started.

Factory Preset: REPEAT

Remarks: You must be in the GSM, EDGE mode to use this command. Use INSTRUMENT:SELECT to set the mode.

Transmit Band Spurs—Averaging Type

```
[ :SENSE ] : TSPur : AVERAGE : TYPE LOG | MAXimum | RMS
```

```
[ :SENSE ] : TSPur : AVERAGE : TYPE?
```

Select the type of averaging.

LOG - The log of the power is averaged. (This is also known as video averaging.)

MAXimum - The maximum values are retained.

RMS - The power is averaged, providing the rms of the voltage.

Factory Preset: MAXimum

Remarks: You must be in the GSM, EDGE mode to use this command. Use INSTRUMENT:SELECT to set the mode.

Transmit Band Spurs—Type

```
[ :SENSE ] : TSPur : TYPE EXAMine | FULL
```

```
[ :SENSE ] : TSPur : TYPE?
```

Select the measurement type.

EXAMine - measures spurs in all the valid segments and then displays the segment that has the worst spur

FULL - continuously measures the spurs in all the valid segments

Factory Preset: FULL

Remarks: You must be in the GSM, EDGE mode to use this command. Use INSTRUMENT:SELECT to set the mode.

Transmit Power Measurement

Commands for querying the transmit power measurement results and for setting to the default values are found in the “MEASure Group of Commands” on page 206. The equivalent front panel keys for the parameters described in the following commands, are found under the **Meas Setup** key, after the **Transmit Power** measurement has been selected from the **MEASURE** key menu.

Transmit Power—Number of Bursts Averaged

```
[ :SENSe ] :TXPower :AVERAge :COUNT <integer>
```

```
[ :SENSe ] :TXPower :AVERAge :COUNT?
```

Set the number of bursts that will be averaged. After the specified number of bursts (average counts), the averaging mode (terminal control) setting determines the averaging action.

Factory Preset: 50

Range: 1 to 10,000

Remarks: You must be in the GSM, EDGE mode to use this command. Use INSTRument:SElect to set the mode.

Transmit Power—Averaging State

```
[ :SENSe ] :TXPower :AVERAge [ :STATe ] OFF | ON | 0 | 1
```

```
[ :SENSe ] :TXPower :AVERAge [ :STATe ]?
```

Turn averaging on or off.

Factory Preset: ON

Remarks: You must be in the GSM, EDGE mode to use this command. Use INSTRument:SElect to set the mode.

Transmit Power—Averaging Mode

```
[ :SENSe ] :TXPower :AVERAge :TCONtrol EXPonential | REPEAT
```

```
[ :SENSe ] :TXPower :AVERAge :TCONtrol?
```

Select the type of termination control used for the averaging function. This determines the averaging action after the specified number of frames (average count) is reached.

EXPonential - Each successive data acquisition after the average count is reached, is exponentially weighted and combined with the existing average.

REPEAT - After reaching the average count, the averaging is reset

and a new average is started.

Factory Preset: EXPOnential

Remarks: You must be in the GSM, EDGE mode to use this command. Use INSTRument:SElect to set the mode.

Transmit Power—Averaging Type

```
[ :SENSe ]:TXPower:AVERAge:TYPE
```

```
[ :SENSe ]:TXPower:AVERAge:TYPE?
```

Select the type of averaging to be performed.

- LOG - The log of the power is averaged. (This is also known as video averaging.)
- MAXimum - The maximum values are retained.
- MINimum - The minimum values are retained.
- RMS - The power is averaged, providing the rms of the voltage.

Factory Preset:

Remarks: You must be in the GSM, EDGE mode to use this command. Use INSTRument:SElect to set the mode.

Transmit Power—Resolution BW

```
[ :SENSe ]:TXPower:BANDwidth|BWIDth[:RESolution] <freq>
```

```
[ :SENSe ]:TXPower:BANDwidth|BWIDth[:RESolution]?
```

Set the resolution BW. This is an advanced control that normally does not need to be changed. Setting it to a value other than the factory default, may cause invalid measurement results.

Factory Preset: 500 kHz

Range: 1 kHz to 5 MHz

Default Unit: Hz

Remarks: You must be in the GSM, EDGE mode to use this command. Use INSTRument:SElect to set the mode.

Transmit Power—Resolution BW Filter Type

```
[ :SENSe ]:TXPower:BANDwidth|BWIDth[:RESolution]:TYPE
```

```
FLAT|GAUSSian
```

```
[ :SENSe ]:TXPower:BANDwidth|BWIDth[:RESolution]:TYPE?
```

Select the type of resolution BW filter. This is an advanced control that normally does not need to be changed. Setting this to a value other than the factory default, may cause invalid measurement results.

Flat top (FLAT) - a filter with a flat amplitude response, which provides the best amplitude accuracy.

GAUSSian - a filter with Gaussian characteristics, which provides the best pulse response.

Factory Preset: GAUSSian

Remarks: You must be in the GSM, EDGE mode to use this command. Use INSTRument:SElect to set the mode.

Transmit Power—Sweep Time

```
[ :SENSe ] :TXPower :SWEep :TIME <integer>
```

```
[ :SENSe ] :TXPower :SWEep :TIME?
```

Set the number of slots which are used in each data acquisition. Each slot is approximately equal to 600 ms.

Factory Preset: 1

Range: 1 to 50 time slots (for resolution BW = 500 kHz)

Remarks: You must be in the GSM, EDGE or Service mode to use this command. Use INSTRument:SElect to set the mode.

Transmit Power—Threshold Level

```
[ :SENSe ] :TXPower :THReshold <power>
```

```
[ :SENSe ] :TXPower :THReshold?
```

Set the amplitude threshold level. Only the data above the threshold level is kept and used to compute the average transmit carrier power.

Factory Preset: -6.0 dB

Range: -100 dB to 0 dB, for relative mode
-100 dBm to +30 dB, for absolute mode

Default Unit: dB for relative mode
dBm for absolute mode

Remarks: The command (SENSe:TXPower:THReshold:TYPE ABSolute | RELative) determines whether this command is setting an absolute or a relative power level.

You must be in the GSM, EDGE mode to use this command. Use INSTRUMENT:SELEct to set the mode.

Transmit Power—Threshold Type

```
[ :SENSE]:TXPower:THReshold:TYPE ABSolute|RELative
```

```
[ :SENSE]:TXPower:THReshold:TYPE?
```

Select auto or manual control of the threshold level.

ABSolute - threshold value is set to an absolute power level

RELative - threshold value is set relative to the reference

Factory Preset: RELative

Remarks: You must be in the GSM, EDGE mode to use this command. Use INSTRUMENT:SELEct to set the mode.

Transmit Power—Trigger Source

```
[ :SENSE]:TXPower:TRIGger:SOURce
```

```
EXTErnal[1]|EXTErnal2|IF|IMMEdiate|RFBurst
```

```
[ :SENSE]:TXPower:TRIGger:SOURce?
```

Select the trigger source used to control the data acquisitions.

EXTErnal 1 - front panel external trigger input

EXTErnal 2 - rear panel external trigger input

IF - internal IF envelope (video) trigger

IMMEdiate - the next data acquisition is immediately taken (also called free run)

RFBurst - wideband RF burst envelope trigger that has automatic level control for periodic burst signals.

Factory Preset: RFBurst

Remarks: You must be in the GSM, EDGE mode to use this command. Use INSTRUMENT:SELEct to set the mode.

Waveform (Time-Domain) Measurement

Commands for querying the waveform measurement results and for setting to the default values are found in the “[MEASure Group of Commands](#)” on page 206. The equivalent front panel keys for the parameters described in the following commands, are found under the **Meas Setup** key, after the **Waveform (Time Domain)** measurement has been selected from the **MEASURE** key menu.

Waveform—Data Acquisition Packing

```
[ :SENSe ] :WAVEform:ACQuistion:PACKing AUTO|LONG|MEDIum|SHORT
```

```
[ :SENSe ] :WAVEform:ACQuistion:PACKing?
```

This is an advanced control that normally does not need to be changed.

Factory Preset: AUTO

Remarks: You must be in the Basic, cdmaOne, cdma2000, W-CDMA, GSM, EDGE, NADC, or PDC mode to use this command. Use INSTRument:SElect to set the mode.

Waveform—ADC Dither State

```
[ :SENSe ] :WAVEform:ADC:DITHer [ :STATe ] OFF|ON|0|1
```

```
[ :SENSe ] :WAVEform:ADC:DITHer [ :STATe ]?
```

This is an Advanced control that normally does not need to be changed.

Factory Preset: OFF

Remarks: You must be in the Basic, cdmaOne, cdma2000, W-CDMA, GSM, EDGE, NADC, or PDC mode to use this command. Use INSTRument:SElect to set the mode.

Waveform—Pre-ADC Bandpass Filter

```
[ :SENSe ] :WAVEform:ADC:FILTer [ :STATe ] OFF|ON|0|1
```

```
[ :SENSe ] :WAVEform:ADC:FILTer [ :STATe ]?
```

Turn the pre-ADC bandpass filter on or off. This is an Advanced control that normally does not need to be changed.

Preset: OFF

Remarks: You must be in the Basic, cdmaOne, cdma2000, W-CDMA, GSM, EDGE, NADC, or PDC mode to use this command. Use INSTRument:SElect to set the

mode.

Waveform—ADC Range

```
[ :SENSE ] :WAVEform:ADC:RANGe
AUTO | APEak | APLOCK | GROund | NONE | P0 | P6 | P12 | P18
```

```
[ :SENSE ] :WAVEform:ADC:RANGe?
```

Select the range for the gain-ranging that is done in front of the ADC. This is an Advanced control that normally does not need to be changed.

AUTO - automatic range

Auto Peak (APEak) - automatically peak the range

Auto Peak Lock (APLOCK)- automatically peak lock the range

GROund - ground

NONE - turn off auto-ranging without making any changes to the current setting.

P0 to P18 - adds 0 to 18 dB of fixed gain across the range

Factory Preset: AUTO

Remarks: You must be in the Basic, cdmaOne, cdma2000, W-CDMA, GSM, EDGE, NADC, or PDC mode to use this command. Use INSTRUMENT:SElect to set the mode.

Waveform - Query Aperture Setting

```
[ :SENSE ] :WAVEform:APERTure?
```

Returns the waveform sample period (aperture) based on current resolution bandwidth, filter type, and decimation factor. Sample rate is the reciprocal of period.

Remarks: You must be in the Basic, cdmaOne, cdma2000, W-CDMA, GSM, EDGE, NADC, or PDC mode to use this command. Use INSTRUMENT:SElect to set the mode.

Waveform—Number of Averages

```
[ :SENSE ] :WAVEform:AVERAge:COUNT <integer>
```

```
[ :SENSE ] :WAVEform:AVERAge:COUNT?
```

Set the number of sweeps that will be averaged. After the specified

number of sweeps (average counts), the averaging mode (terminal control) setting determines the averaging action.

Factory Preset: 10

Range: 1 to 10,000

Remarks: You must be in the Basic, cdmaOne, cdma2000, W-CDMA, GSM, EDGE, NADC, or PDC mode to use this command. Use INSTRument:SElect to set the mode.

Waveform—Averaging State

```
[ :SENSe ] :WAVeform:AVERAge [ :STATe ] OFF | ON | 0 | 1
```

```
[ :SENSe ] :WAVeform:AVERAge [ :STATe ] ?
```

Turn averaging on or off.

Factory Preset: OFF

Remarks: You must be in the Basic, cdmaOne, cdma2000, W-CDMA, GSM, EDGE, NADC, or PDC mode to use this command. Use INSTRument:SElect to set the mode.

Waveform—Averaging Mode

```
[ :SENSe ] :WAVeform:AVERAge:TCONtrol EXPonential | REPeat
```

```
[ :SENSe ] :WAVeform:AVERAge:TCONtrol ?
```

Select the type of termination control used for the averaging function. This determines the averaging action after the specified number of 'sweeps' (average count) is reached.

EXPonential - Each successive data acquisition after the average count is reached, is exponentially weighted and combined with the existing average.

REPeat - After reaching the average count, the averaging is reset and a new average is started.

Factory Preset: EXPonential

Remarks: You must be in the Basic, cdmaOne, cdma2000, W-CDMA, GSM, EDGE, NADC, or PDC mode to use this command. Use INSTRument:SElect to set the mode.

Waveform—Averaging Type

```
[ :SENSE ] :WAVEform:AVERage:TYPE  
LOG | MAXimum | MINimum | RMS | SCALar
```

```
[ :SENSE ] :WAVEform:AVERage:TYPE?
```

Select the type of averaging.

LOG - The log of the power is averaged. (This is also known as video averaging.)

MAXimum - The maximum values are retained.

MINimum - The minimum values are retained.

RMS - The power is averaged, providing the rms of the voltage.

Factory Preset: RMS

Remarks: You must be in the Basic, cdmaOne, cdma2000, W-CDMA, GSM, EDGE, NADC, or PDC mode to use this command. Use INSTRument:SElect to set the mode.

Waveform—Resolution BW

```
[ :SENSE ] :WAVEform:BANDwidth|BWIDth[:RESolution] <freq>
```

```
[ :SENSE ] :WAVEform:BANDwidth|BWIDth[:RESolution]?
```

Set the resolution bandwidth. This value is ignored if the function is auto-coupled.

Factory Preset: 100.0 kHz for NADC, PDC, cdma2000, W-CDMA, Basic
500.0 kHz for GSM
2.0 MHz for cdmaOne

Range: 1.0 kHz to 5.0 MHz

Remarks: You must be in the Basic, cdmaOne, cdma2000, W-CDMA, GSM, EDGE, NADC, or PDC mode to use this command. Use INSTRument:SElect to set the mode.

Waveform - Query Actual Resolution Bandwidth

```
[ :SENSE ] :WAVEform:BANDwidth:RESolution]:ACTual?
```

Due to memory constraints the actual resolution bandwidth value may vary from the value entered by the user. For most applications the resulting difference in value is inconsequential but for some it is necessary to know the actual value; this query retrieves the actual

resolution bandwidth value.

Remarks: You must be in the Basic, cdmaOne, cdma2000, W-CDMA, GSM, EDGE, NADC, or PDC mode to use this command. Use INSTRument:SElect to set the mode.

Waveform—Resolution BW Filter Type

```
[ :SENSe ] :WAVeform :BANDwidth | BWIDth [ :RESolution ] :TYPE  
FLATtop | GAUSSian
```

```
[ :SENSe ] :WAVeform :BANDwidth | BWIDth [ :RESolution ] :TYPE?
```

Select the type of Resolution BW filter that is used. This is an Advanced control that normally does not need to be changed.

FLATtop - a filter with a flat amplitude response, which provides the best amplitude accuracy.

GAUSSian - a filter with Gaussian characteristics, which provides the best pulse response.

Factory Preset: GAUSSian

Remarks: You must be in the Basic, cdmaOne, cdma2000, W-CDMA, GSM, EDGE, NADC, or PDC mode to use this command. Use INSTRument:SElect to set the mode.

Waveform—Decimation of Waveform Display

```
[ :SENSe ] :WAVeform :DECimate [ :FACTOR ] <integer>
```

```
[ :SENSe ] :WAVeform :DECimate [ :FACTOR ]?
```

Set the amount of data decimation done on the IQ data stream. For example, if 4 is selected, three out of every four data points will be thrown away. So every 4th data point will be kept.

Factory Preset: 1

Range: 1 to 4

Remarks: You must be in the Basic, cdmaOne, cdma2000, W-CDMA, GSM, EDGE, NADC, or PDC mode to use this command. Use INSTRument:SElect to set the mode.

Waveform—Control Decimation of Waveform Display

[:SENSE] :WAVEform:DECimate:STATE OFF | ON | 0 | 1

[:SENSE] :WAVEform:DECimate:STATE?

Set the amount of data decimation done by the hardware in order to decrease the number of acquired points in a long capture time. This is the amount of data that the measurement ignores.

Factory Preset: OFF

Remarks: You must be in the Basic, cdmaOne, cdma2000, W-CDMA, GSM, EDGE, NADC, or PDC mode to use this command. Use INSTRUMENT:SElect to set the mode.

Waveform—Sweep (Acquisition) Time

[:SENSE] :WAVEform:SWEep:TIME <time>

[:SENSE] :WAVEform:SWEep:TIME?

Set the measurement acquisition time. It is used to specify the length of the time capture record.

Factory Preset: 2.0 ms

10.0 ms, for NADC, PDC

Range: 1 μ s to 100 s

Default Unit: seconds

Remarks: You must be in the Basic, cdmaOne, cdma2000, W-CDMA, GSM, EDGE, NADC, or PDC mode to use this command. Use INSTRUMENT:SElect to set the mode.

Waveform—Trigger Source

[:SENSE] :WAVEform:TRIGger:SOURce EXTErnal[1] |
EXTErnal2 | FRAME | IF | IMMEDIATE | LINE | RFBurst

[:SENSE] :WAVEform:TRIGger:SOURce?

Select the trigger source used to control the data acquisitions.

EXTErnal 1 - front panel external trigger input

EXTErnal 2 - rear panel external trigger input

FRAME - internal frame timer from front panel input

IF - internal IF envelope (video) trigger

IMMediate - the next data acquisition is immediately taken (also called free run)

LINE - internal line trigger

RFBurst - wideband RF burst envelope trigger that has automatic level control for periodic burst signals

Factory Preset: IMMediate (free run), for Basic, cdmaOne, NADC, PDC mode

RFBurst, for GSM mode

Remarks: You must be in the Basic, cdmaOne, cdma2000, W-CDMA, GSM, EDGE, NADC, or PDC mode to use this command. Use INSTRument:SElect to set the mode.

TRIGger Subsystem

The Trigger Subsystem is used to set the controls and parameters associated with triggering the data acquisitions. Other trigger-related commands are found in the INITiate and ABORt subsystems.

The trigger parameters are global within a selected Mode. The commands in the TRIGger subsystem set up the way the triggers function, but selection of the trigger source is made from each measurement. There is a separate trigger source command in the SENSE:<meas> subsystem for each measurement. The equivalent front panel keys for the parameters described in the following commands, can be found under the **Mode Setup, Trigger** key.

Automatic Trigger Control

```
:TRIGger[:SEquence]:AUTO:STATE OFF|ON|0|1
```

```
:TRIGger[:SEquence]:AUTO:STATE?
```

Turns the automatic trigger function on and off. This function causes a trigger to occur if the designated time has elapsed and no trigger occurred. It can be used with unpredictable trigger sources, like external or burst, to make sure a measurement is initiated even if a trigger doesn't occur. Use TRIGger[:SEquence]:AUTO[:TIME] to set the time limit.

Factory Preset

and *RST Off for cdma2000, W-CDMA, NADC, PDC, 1xEV-DO

Front Panel

Access **Mode Setup, Trigger, Auto Trig**

Automatic Trigger Time

```
:TRIGger[:SEquence]:AUTO[:TIME] <time>
```

```
:TRIGger[:SEquence]:AUTO[:TIME]?
```

After the measurement is activated the instrument will take a data acquisition immediately upon receiving a signal from the selected trigger source. If no trigger signal is received by the end of the time specified in this command, a data acquisition is taken anyway. TRIGger[:SEquence]:AUTO:STATE must be on.

Factory Preset: 100.0 ms

Range: 1.0 ms to 1000.0 s

0.0 to 1000.0 s for cdma2000, W-CDMA, 1xEV-DO

Default Unit: seconds

External Trigger Delay

```
:TRIGger[:SEQuence]:EXTErnal[1]|2:DELAy <time>
```

```
:TRIGger[:SEQuence]:EXTErnal[1]|2:DELAy?
```

Set the trigger delay when using an external trigger. Set the trigger value to zero (0) seconds to turn off the delay.

EXT or EXT1 is the front panel trigger input

EXT2 is the rear panel trigger input

Factory Preset: 0.0 s

Range: -100.0 ms to 100.0 ms
-100.0 ms to 500.0 ms for 1xEV-DO

Default Unit: seconds

Front Panel

Access: **Mode Setup, Trigger, Ext Rear (or Ext Front), Delay**

External Trigger Level

```
:TRIGger[:SEQuence]:EXTErnal[1]|2:LEVEl <voltage>
```

```
:TRIGger[:SEQuence]:EXTErnal[1]|2:LEVEl?
```

Set the trigger level when using an external trigger input.

EXT or EXT1 is the front panel trigger input

EXT2 is the rear panel trigger input

Factory Preset: 2.0 V

Range: -5.0 to +5.0 V

Default Unit: volts

Front Panel

Access: **Mode Setup, Trigger, Ext Rear, Level**
Mode Setup, Trigger, Ext Front, Level

External Trigger Slope

```
:TRIGger[:SEQuence]:EXTErnal[1]|2:SLOPe NEGative|POSitive
```

:TRIGger[:SEquence]:EXTernal[1]|2:SLOPe?

Sets the trigger slope when using an external trigger input.

EXT or EXT1 is the front panel trigger input

EXT2 is the rear panel trigger input

Factory Preset: Positive

Front Panel

Access: **Mode Setup, Trigger, Ext Rear (or Ext Front), Slope**

Frame Trigger Adjust

:TRIGger[:SEquence]:FRAMe:ADJust <time>

Lets you advance the phase of the frame trigger by the specified amount. It does not change the period of the trigger waveform. If the command is sent multiple times, it advances the phase of the frame trigger more each time it is sent.

Factory Preset: 0.0 s

Range: 0.0 to 10.0 s

Default Unit: seconds

Front Panel

Access: None

Frame Trigger Period

:TRIGger[:SEquence]:FRAMe:PERiod <time>

:TRIGger[:SEquence]:FRAMe:PERiod?

Set the frame period that you want when using the external frame timer trigger. If the traffic rate is changed, the value of the frame period is initialized to the preset value.

Factory Preset: 250.0 μ s for Basic, cdmaOne

4.615383 ms, for GSM

26.666667 ms for cdma2000 and 1xEV-DO

10.0 ms (1 radio frame) for W-CDMA

20.0 ms with rate=full for NADC, PDC

40.0 ms with rate=half for NADC, PDC

Range: 0.0 ms to 559.0 ms for Basic, cdmaOne, GSM, cdma2000, W-CDMA, 1xEV-DO

1.0 ms to 559.0 ms for NADC, PDC

Default Unit: seconds

Front Panel

Access: Mode Setup, Trigger, Frame Timer, Period

Frame Trigger Sync Source

```
:TRIGger[:SEquence]:FRAME:SYNC EXTFront|EXTRear|OFF
```

```
:TRIGger[:SEquence]:FRAME:SYNC?
```

Selects the input port location for the external frame trigger that you are using.

Factory Preset: Off

Remarks: You must be in the Basic, cdmaOne, EDGE (w/GSM), GSM, NADC, PDC, Service mode to use this command. Use INSTRument:SElect to set the mode.

Front Panel

Access: Mode Setup, Trigger, Frame Timer, Sync Source

History Changed firmware revision A.05.00.

Frame Trigger Synchronization Offset

```
:TRIGger[:SEquence]:FRAME:SYNC:OFFSet <time>
```

```
:TRIGger[:SEquence]:FRAME:SYNC:OFFSet?
```

Lets you adjust the frame triggering with respect to the external trigger input that you are using.

Factory Preset: 0.0 s

Range: 0.0 to 10.0 s

Default Unit: seconds

Remarks: You must be in the Basic, cdmaOne, GSM, EDGE, NADC, PDC, Service mode to use this command. Use INSTRument:SElect to set the mode.

History: Revision A.03.27 or later

Front Panel

Access: Mode Setup, Trigger, Frame Timer, Offset

Trigger Holdoff

:TRIGger[:SEquence]:HOLDoff <time>

:TRIGger[:SEquence]:HOLDoff?

Set the holdoff time between triggers. After a trigger, another trigger will not be allowed until the holdoff time expires. This parameter affects all trigger sources.

Factory Preset: 0.0 s

10.0 ms for NADC or PDC

Range: 0.0 to 500.0 ms

Default Unit: seconds

Front Panel

Access: Mode Setup, Trigger, Trig Holdoff

Video (IF) Trigger Delay

:TRIGger[:SEquence]:IF:DElay <time>

:TRIGger[:SEquence]:IF:DElay?

Set the trigger delay when using the IF (video) trigger (after the Resolution BW filter).

Factory Preset: 0.0 s

Range: -100.0 ms to 500.0 ms

-100.0 ms to 100.0 ms for cdma2000, W-CDMA

Default Unit: seconds

Front Panel

Access: Mode Setup, Trigger, Video (IF Envlp), Delay

Video (IF) Trigger Level

:TRIGger[:SEquence]:IF:LEvel <ampl>

:TRIGger[:SEquence]:IF:LEvel?

Set the trigger level when using the IF (video) trigger.

Factory Preset: -6.0 dBm for cdmaOne, GSM, EDGE, Basic, cdma2000, W-CDMA, 1xEV-DO

-30.0 dBm for NADC, PDC

Range: -200.0 to 50.0 dBm

Programming Commands
TRIGger Subsystem

Default Unit: dBm

Front Panel

Access: **Mode Setup, Trigger, Video (IF Envlp), Level**

Video (IF) Trigger Slope

`:TRIGGER[:SEQUENCE]:IF:SLOPE NEGATIVE|POSITIVE`

`:TRIGGER[:SEQUENCE]:IF:SLOPE?`

Sets the trigger slope when using the IF (video) trigger.

Factory Preset: Positive

Front Panel

Access: **Mode Setup, Trigger, Video (IF Envlp), Slope**

RF Burst Trigger Delay

`:TRIGGER[:SEQUENCE]:RFBURST:DELAY <time>`

`:TRIGGER[:SEQUENCE]:RFBURST:DELAY?`

Set the trigger delay when using the RF burst (wideband) trigger.

Factory Preset: 0.0 s

Range: -100.0 ms to 500.0 ms

Default Unit: seconds

Front Panel

Access: **Mode Setup, Trigger, RF Burst, Delay**

RF Burst Trigger Level

`:TRIGGER[:SEQUENCE]:RFBURST:LEVEL <rel_power>`

`:TRIGGER[:SEQUENCE]:RFBURST:LEVEL?`

Set the trigger level when using the RF Burst (wideband) Trigger. The value is relative to the peak of the signal. RF Burst is also known as RF Envelope.

Factory Preset: -6.0 dB

Range: -25.0 to 0.0 dB
-200.0 to 0.0 dB for NADC, PDC

Default Unit: dB

Front Panel

Access: **Mode Setup, Trigger, RF Burst, Peak Level**

RF Burst Trigger Slope

`:TRIGger[:SEQuence]:RFBurst:SLOPe NEGative|POSitive`

`:TRIGger[:SEQuence]:RFBurst:SLOPe?`

Set the trigger slope when using the RF Burst (wideband) Trigger.

Factory Preset: Positive

Remarks: You must be in the cdmaOne, cdma2000, W-CDMA mode to use this command. Use `:INSTrument:SElect` to set the mode.

Front Panel

Access: **Mode Setup, Trigger, RF Burst, Slope**

A

- acquisition packing
 - WAVeform, 326
- active license key, 64
 - how to locate, 64
- ADC dithering
 - SPECTrum, 307
 - WAVeform, 326
- ADC filter
 - WAVeform, 326
- ADC range
 - SPECTrum, 307
 - WAVeform, 327
- ADC ranging function
 - automatic control, 150, 158
 - automatic control to peak, 150
 - automatic peak control, 150, 158
 - automatic peak lock, 158
 - manual control, 150, 158
- Advanced menu
 - waveform, 158
- advanced menu
 - ADC dither, 150, 159
 - ADC ranging function, 150, 158
 - data packing, 158
 - data packing menu, 150
 - decimation, 151, 159
 - FFT size menu, 149
 - FFT window menu, 149
 - IF flatness, 151
 - pre-ADC bandpass filter, 149, 158
 - pre-FFT bandwidth, 149
 - pre-FFT filter, 149
 - resolution bandwidth filter, 158
- amplitude
 - input range, 291
 - maximizing input signal, 291
- amplitude Y scale
 - reference position, 160, 161
 - reference value, 160, 161
 - scale coupling, 160, 161
 - scale per division, 160, 161
- ANSI standards, 31
- applications, selecting, 203, 204
- ARFCN definition, 31
- ARFCN setting, 237, 238, 239
- ASCII data format, 198
- attenuation
 - setting, 291
- averaging
 - CSPur, 272, 321
 - EVM, 244
 - ORFSpectrum, 248, 249, 274, 275

- output RF spectrum, 248, 249, 274, 275
- phase & frequency error, 287, 288
- phase and frequency error measurement, 287
- power vs. time, 260, 261, 293, 294
- SPECTrum, 308, 309, 310
- transmit band spurs, 271, 320, 327
- transmit power, 322, 323
- WAVeform, 327, 328, 329

averaging state

- power vs. time, 260, 293

B

- bandwidth
 - ORFSpectrum, 249, 251, 252, 276, 277, 280
 - output RF spectrum, 250, 251, 252, 276, 277, 279
 - power vs. time, 261, 294
 - PVTime, 262, 295
 - SPECTrum, 312, 313
 - transmit power, 323
 - TXPower, 323
 - WAVeform, 329, 330
- base station testing, 304
 - type, 305
- base transmit station
 - loss correction, 243
- binary data order, 198
- burst carriers, 304
- burst synchronization, 245
 - power vs. time, 262, 295
- burst trigger
 - level, 339
- byte order of data, 198

C

- carrier
 - type, 304
- changing
 - instrument settings, 237
- channel burst type, 239
- channel number
 - ARFCN, 237, 238, 239
- Choose Option key, 64
- commands
 - CONFigure, 207
 - FETCh, 208
 - MEASure, 206
 - READ, 207, 208
- CONFigure command use, 206
- CONFigure commands, 207
- continuous carriers, 304

- continuous vs. single measurement mode, 200
- control measurement commands, 200
- correction
 - base transmit station loss, 243
 - mobile station loss, 243
- current measurement, 187
- curve fit the data, 166, 172

D

- data
 - querying, 165, 166, 172
- data decimation, 314
 - WAVeform, 330, 331
- data format, 198
- data from measurements, 206
- data packing
 - 16 bit short packing, 159
 - 24 bit medium packing, 159
 - 32 bit long packing, 159
 - automatic control, 159
- data packing menu
 - 16 bit short packing, 150
 - 24 bit medium packing, 150
 - 32 bit long packing, 150
 - automatic packing, 150
- DCS1800, 305
- decimation
 - SPECTrum, 314
- decimation of data
 - WAVeform, 330, 331
- default states, 34
- default values, setting remotely, 207
- deleting an
 - application/personality, 62
- delta markers, 177, 179
- display
 - PVT limits, 188, 189
 - spectrum window, 189, 190, 195
 - tiling, 188
 - trace, 191
 - window tile, 188
 - zoom, 188
- display commands, 188
- dithering of ADC
 - WAVeform, 326
- dithering the ADC, 307
- downlink
 - definition of, 31

E

- EDGE EVM
 - key flow diagram, 53
- EDGE ORFS
 - key flow diagram, 54

- EDGE Pwr vs Time
 - key flow diagram, 52
- EDGE transmit band spurs
 - measurement, 271
- EDGE Tx Band Spur
 - key flow diagram, 56
- EGSM
 - RGSM
 - DCS, 305
- error vector magnitude
 - measuring, 121
- error vector magnitude measurement, 210, 244
- error vector measurement
 - See also EVM
- ETSI standards, 29
- EVM
 - averaging, 244
 - burst synchronization, 245
 - symbol dots, 245, 246
 - trigger source, 247
- external trigger
 - delay, 334
 - level, 334
 - slope, 335
- F**
- FETCh command use, 206
- FETCh commands, 208
- FFT
 - SPECTrum, 314, 315, 316
- FFT bandwidth, SPECTrum, 311, 312
- FFT size menu
 - FFT length, 150
 - length control, 149
 - minimum points in resolution bandwidth, 149
 - window length, 150
- FFT window
 - Blackman, 149
 - Blackman Harris, 149
 - flat top, 149
 - Gaussian, 149
 - hamming, 149
 - hanning, 149
 - Keiser-Bessel 110 dB filter, 149
 - Keiser-Bessel 70 dB filter, 149
 - Keiser-Bessel 90 dB filter, 149
 - uniform, 149
- format, data, 198
- frame trigger adjustment, 335, 336
- frame trigger period, 335
- frame trigger sync mode, 336
- frequency offsets
 - ORFSpectrum, 253, 254, 280
 - output RF spectrum, 281
- frequency span
 - SPECTrum, 317
- Full Frame Modulation (FAST), 102, 137, 258, 285
- G**
- GSM measurement, 254, 256, 260, 281, 283, 293, 322
- GSM ORFS
 - key flow diagram, 50
- GSM Phase and Freq
 - key flow diagram, 49
- GSM Pwr.vs.Time
 - key flow diagram, 48
- GSM standards
 - DCS 1800, 27, 36
 - E-GSM, 27, 36
 - GSM 1900, 27, 36
 - GSM 450, 27, 36
 - GSM 480, 27, 36
 - GSM 700, 27, 36
 - GSM 850, 27, 36
 - GSM 900, 27, 36
 - PCS 1900, 27, 36
 - P-GSM, 27, 36
 - R-GSM, 27, 36
- GSM Tx Band Spur
 - key flow diagram, 51
- GSM450, 305
- GSM480, 305
- GSM850, 305
- H**
- hopping carriers, 304
- I**
- I waveform window
 - amplitude Y scale, 161
- I/Q data results, 229, 234
- I/Q waveform view
 - I/Q waveform window, 161
- I/Q waveform window
 - amplitude Y scale, 161
 - span X scale
 - reference position, 160
 - reference value, 160
 - scale coupling, 160
 - scale per division, 160
- IF trigger delay, 337
- IF trigger level, 337
- IF trigger slope, 339
- initiate measurement, 200, 201
- input attenuation, 291
- input port selection, 273
- input power
 - maximum, 291
 - range, 291
- Install Now key, 64
- installing measurement personalities, 62
- instrument configuration, 203
- internal reference selection, 273
- IQ port selection, 273
- K**
- key flow diagrams, 44
- L**
- limit line testing, 165
- limit testing
 - TSPur, 174, 186
- loading an
 - application/personality, 62
- M**
- making measurements, 206
- markers, 175
 - assigning them to traces, 180
 - maximum, 178
 - minimum, 178
 - off, 179
 - trace assignment, 184
 - turn off, 177
 - type, 177, 179
 - valid measurement, 175
 - value, 185
 - value of, 178
 - x-axis location, 184
 - y-axis, 185
- masks
 - power vs. time, 262, 263, 264, 265, 266, 267, 295, 296, 297, 298, 299, 301
- maximum value of trace data, 166, 172
- mean value of trace data, 166, 172
- MEASure command use, 206
- MEASure commands, 206
- measurement
 - error vector magnitude, 244
 - markers, 175
 - output RF spectrum, 248, 274
 - phase and frequency error, 287
 - power vs. time, 260, 293
 - query current, 187
 - spectrum (frequency domain), 146, 148, 307
 - transmit band spurs, 271, 320
 - transmit power, 322
 - waveform (time domain), 326
- measurement method

- output RF spectrum, 257, 284
- measurement modes
 - selecting, 203, 204
- measurement setup
 - advanced menu, 146, 149
 - resolution bandwidth, 148
 - span, 148
- measurement type
 - transmit band spurs, 272, 321
- measurements
 - CONF/FETC/MEAS/READ commands, 206
 - control of, 200
 - error vector magnitude, 210
 - getting results, 206
 - output RF spectrum, 213, 220
 - phase and frequency error, 223
 - power vs. time, 216, 226
 - setting default values remotely, 207
 - single/continuous, 200
 - spectrum (frequency domain), 229
 - transmit band spurs, 219, 231
 - transmit power, 232
 - waveform (time domain), 234
- measuring I/Q data, 229, 234
- menu maps
 - key flow diagrams, 44
- micro base station, 305
- minimum value of trace data, 166, 172
- mobile station
 - loss correction, 243
- mobile station testing, 304
- Mode Setup key, 36

- N**
- normal marker, 177, 179

- O**
- offset frequency
 - output RF spectrum, 257, 284
- options
 - loading/deleting, 62
- ORFS,improving measurement speed, 102, 137, 258, 285
- ORFSpectrum
 - bandwidth, 252, 280
 - bandwith, 255, 282
- l offset
 - output RF spectrum
 - measurement, 254, 256, 281, 283
 - measurement type, 258, 285
 - offsets, 253, 254, 256, 257, 280, 283, 284
- output RF spectrum
 - resolution bandwidth for switching transients at close offsets, 251, 277
 - trigger source, 258, 285
- output RF spectrum - averaging control, 249, 275
- output RF spectrum - number of bursts averaged, 248, 274
- output RF spectrum - offset frequency, 257, 284
- output RF spectrum - offset frequency list, 281
- output RF spectrum - resolution bandwidth for switching transients at far offsets, 252, 279
- output RF spectrum - resolution BW for modulation at close offsets, 250, 276
- output RF spectrum - resolution BW for modulation at far offsets, 250, 277
- output RF spectrum measurement, 213, 220, 248, 274
- See also orfspectrum
- output RF spectrum measurement method, 257, 284

- P**
- packing
 - SPECTrum, 307
- pass/fail test, 165
- PCS, 305
- PCS1900, 305
- personalities
 - selecting, 203, 204
- PGSM, 305
- phase & frequency error - averaging mode, 287
- phase & frequency error - averaging state, 287
- phase & frequency error - averaging type, 288
- phase & frequency error - burst synchronization, 288
- phase & frequency error - number of bursts averaged, 287
- phase & frequency error - trigger source, 290
- phase and frequency error measurement, 223, 287
- See also PFERror
- pico base station, 305
- power vs. time
 - averaging state, 260, 293
 - power vs. time - averaging mode, 260, 293
 - power vs. time - averaging type, 261, 294
 - power vs. time - burst synchronization source, 262, 295
 - power vs. time - custom limit masks, 265, 301
 - power vs. time - limit line mask display, 262, 295
 - power vs. time - lower mask absolute amplitude levels, 263, 296
 - power vs. time - lower mask points, 263, 296
 - power vs. time - lower mask relative amplitude levels, 264, 297
 - power vs. time - lower mask time points, 264, 297
 - power vs. time - number of bursts averaged, 260, 293
 - power vs. time - resolution bandwidth, 261, 294
 - power vs. time - trigger source, 269, 302
 - power vs. time - upper mask absolute amplitude levels, 265, 298
 - power vs. time - upper mask points, 266, 299
 - power vs. time - upper mask relative amplitude levels, 266, 299
 - power vs. time - upper mask time points, 267, 299
 - power vs. time measurement, 216, 226, 260, 293
 - See also PVTTime
 - pre-ADC bandpass filter SPECTrum, 311
 - pre-FFT bandwidth, SPECTrum, 311, 312
 - preset states, 34
 - PVT limits display, 188, 189
 - PVTTime
 - bandwidth, 262, 295
 - sweep time, 269, 302, 324

- Q**
- Q waveform window
 - amplitude Y scale, 161
- query data, 165, 166, 172

R

READ command use, 206
READ commands, 207, 208
real number data format, 198
rear panel external trigger
 delay, 334
 slope, 335
reference, selecting internal, 273
Res BW key
 waveform measurement, 158
restart measurement, 201
return data, 165, 166, 172
RF envelope view
 RF envelope window, 160
RF envelope window
 span X scale
 reference position, 160
 reference value, 160
 scale coupling, 160
 scale per division, 160
RF input, selection, 273
RMS of trace data, 166, 172

S

sampling trace data, 166, 172
select the ARFCN - absolute RF
 channel number, 237
selecting channel, 239
signal envelope view
 signal envelope window, 160
signal envelope window
 amplitude Y scale, 160
 span X scale
 reference position, 160
 reference value, 160
 scale coupling, 160
 scale per division, 160
single vs. continuous
 measurement mode, 200
slots, setting, 269, 302, 324
span
 SPECTrum, 317
SPECTrum
 acquisition packing, 307
 ADC range, 307
 data decimation, 314
 FFT length, 314, 315
 FFT resolution BW, 315
 FFT window, 316
 FFT window delay, 315
 frequency span, 317
 sweep time, 317, 318
 trigger source, 318
Spectrum
 key flow diagram, 58
spectrum
 amplitude Y scale, 151

 changing the display, 151
 changing views, 151
 making the measurement, 146
 measurement method, 146
 measurement setup, 148, 151
 next window selection, 151
 span, 151
 span X scale, 151
 view/trace menu, 151
 zoom a window, 151
spectrum (frequency domain)
 measurement, 229, 307
 See also SPECTrum
spectrum measurement
 results, 146
spectrum measurement display,
 189, 190, 195
standard deviation of trace data,
 166, 172
standard, selecting for GSM, 305
start measurement, 200, 201
state
 changing, 237
sweep time
 PVTime, 269, 302, 324
 SPECTrum, 317, 318
 WAVEform, 331
Sweep Time key, 158
switching transients
 ORFSpectrum, 255, 256, 282,
 283
symbol dots
 EVM, 245, 246
synchronization
 EVM, 245
 phase & frequency error, 288
 power vs. time, 262, 295

T

test limits, 165
tile the display, 188
time domain measurement, 234,
 326
time slot auto, 240
time slot number, 240
timeslot
 definition of, 31
trace data
 processing, 166, 172
trace display, 191
trace display menu
 all traces, 151
 averaged trace, 152
 current measurement trace, 152
trace format, 198
trace names for markers, 180
training sequence code (TSC), 242

training sequence code (TSC)
 auto, 242
training sequence code channel,
 239
training sequence code selection,
 242
transmit band spurs
 limit testing, 174, 186
transmit band spurs - average
 count, 271, 320
transmit band spurs - averaging
 state, 271, 320, 327
transmit band spurs - averaging
 termination control, 271, 320
transmit band spurs - type, 272,
 321
transmit band spurs
 measurement, 219, 231, 320
Transmit Power
 key flow diagram, 47
transmit power
 resolution bandwidth, 323
transmit power - averaging mode,
 322
transmit power - averaging state,
 322
transmit power - averaging type,
 323
transmit power - number of bursts
 averaged, 322
transmit power measurement,
 232, 322
 See also TXPower
trigger
 auto time, 333
 burst level, 339
 commands, 333
 delay, 334
 delay, IF, 337
 external, 334, 335
 frame adjustment, 335, 336
 frame period, 335
 frame sync mode, 336
 holdoff, 337
 level, 334
 level, IF, 337
 on/off, 333
 output RF spectrum, 258, 285
 phase & frequency error, 290
 power vs. time, 269, 302
 slope, 335
 slope, IF, 339
 SPECTrum, 318
 timeout, 333
 TXPower, 325
 WAVEform, 331
trigger measurement, 200, 201

-
- trigger source
 - EVM, [247](#)
 - TSPur
 - limit testing, [174](#), [186](#)
 - TXPower
 - trigger source, [325](#)
 - U**
 - Uninstall Now, [65](#)
 - uninstalling measurement
 - personalities, [62](#)
 - uplink
 - definition of, [31](#)
 - V**
 - view commands, [188](#)
 - view/trace
 - spectrum and I/Q waveform graphs, [151](#)
 - view/trace menu
 - I/Q waveform view, [161](#)
 - RF envelope view, [160](#)
 - trace display, [151](#)
 - view/trace mmenu
 - signal envelope view, [160](#), [162](#)
 - view/trace selection
 - log envelope graph view, [159](#)
 - magnitude & phase graph view, [159](#)
 - W**
 - WAVeform
 - acquisition packing, [326](#)
 - ADC dithering, [326](#)
 - ADC filter, [326](#)
 - ADC range, [327](#)
 - data decimation, [330](#), [331](#)
 - sweep time, [331](#)
 - trigger source, [331](#)
 - waveform
 - advanced menu, [158](#)
 - changing displays, [160](#)
 - changing views, [159](#)
 - view/trace selection, [159](#)
 - log envelope, [156](#)
 - making the measurement, [155](#)
 - method, [155](#)
 - next window selection, [159](#)
 - resolution bandwidth, [158](#)
 - results, [155](#), [156](#)
 - span X scale, [160](#)
 - sweep time, [158](#), [160](#)
 - using markers, [161](#)
 - zoom a window, [159](#)
 - Waveform (Time Domain) key, [155](#)
 - waveform (time domain)
 - measurement, [234](#), [326](#)
 - See also WAVeform
 - waveform measurement
 - display, [161](#)
 - Waveform.Time
 - key flow diagram, [60](#)
 - Z**
 - zero span measurement, [234](#), [326](#)
 - zoom the display, [188](#)